

I-O Print Box Tx

User's Guide

Version 1.6

| | |
|---|--|
| I-O Print Box Tx DXBXPP-OMAN02-160 © 2000 I-O Corporation | Version 1.6 Revision Date: February, 2000 |
|---|--|

U.S.A.: I-O Corporation
2256 South 3600 West
Salt Lake City, Utah 84119
(801) 973-6767 • Fax: (801) 974-5683

U.K.: I-O Corporation (UK)
9 Centurion Court, Kiln Farm
Milton Keynes MK11 3JB
United Kingdom
44(0) 1908 567722 • Fax: 44 (0) 1908 565599

International: I-O Corporation
2256 South 3600 West
Salt Lake City, Utah 84119
(801) 973-6767 • Fax: (801) 974-5683

Customer Support: I-O Corporation
2256 South 3600 West
Salt Lake City, Utah 84119
(801) 972-1446 • Fax: (801) 973-8042

Internet: <http://www.iocorp.com>

This page left intentionally blank.

PREFACE

I-O Corporation (I-O) is pleased to introduce you to the I-O Print Box TxP plus, TxS plus, and I-O Print Box TxP lite. With the wide range of printing environments found in business today, you can depend on the quality and reliability that has made I-O the leader in printer interface technology.

The five sections contained in the User's Guide will give you the information needed to get the most from your I-O Print Box.

INTRODUCTION - Provides an overview of the I-O Print Box TxP plus, TxS plus and TxP lite, including printer emulations, printers supported, and the adapter cables required for connectivity.

INSTALLATION - Explains how to install the I-O Print Box and how to connect to the host.

CONFIGURATION - Explains the use of the interface's on-board configuration switches, PC setup software, and host download commands.

OPERATION - Provides a detailed overview of host and PC/LAN printing, emulations, font change commands, user-defined command strings, and Command Pass-Thru™.

PROBLEM RESOLUTION - Provides a detailed troubleshooting guide.

Great care has been taken in the preparation of this manual. If you encounter inaccuracies or omissions, please contact us at the address listed in this manual, Attn: Product Manager, Printer Interface Division.

PREFACE

This page left intentionally blank.

TABLE OF CONTENTS

TABLE OF CONTENTS

| | |
|---|-------|
| 1 INTRODUCTION | .1-1 |
| Description of Front Panels | .1-1 |
| Configuration Switches | .1-2 |
| LEDs - The green LED lights indicate the following: | .1-2 |
| About This User's Guide | .1-3 |
| Unpacking | .1-3 |
| 2 INSTALLATION | .2-1 |
| Power On/Off Sequence | .2-4 |
| Self-Test Printout - TxP plus | .2-5 |
| Self-Test Printout - TxP lite | .2-6 |
| Self-Test Printout - TxS plus | .2-7 |
| Page 2 of Self-Test Printouts | .2-8 |
| Page 3 of Self-Test Printouts | .2-9 |
| 3 CONFIGURATION | .3-1 |
| Host Configuration | .3-1 |
| Interface Configuration | .3-2 |
| Switch Settings | .3-2 |
| I-O Setup Software | .3-5 |
| Host/PC Download Commands | .3-6 |
| Host/PC Download Command Overview | .3-7 |
| Configuration Options | .3-10 |
| Restoring Factory Defaults | .3-31 |
| 4 OPERATION | .4-1 |
| Serial Printing | .4-1 |
| Printer Sharing | .4-1 |
| Parallel/Serial Port Initialization | .4-2 |
| Host Printing | .4-2 |
| Host Port Initialization | .4-3 |
| Star Panel Overdrive | .4-3 |
| Laser Printer Operation | .4-3 |
| Changing Typestyles | .4-5 |
| Font Change Commands | .4-5 |
| Page Length | .4-7 |
| Paper Size | .4-7 |
| Printing on 11" x 17" or A3 Size Paper | .4-9 |

TABLE OF CONTENTS

| | |
|--|------------|
| Paper Drawer Selection | 4-9 |
| Paper Output Bin Selection | 4-10 |
| Print Orientation | 4-12 |
| 1. Page Rotation | 4-12 |
| 2. Automatic Print Orientation | 4-14 |
| 3. Print Orientation Settings | 4-14 |
| Changing Page Rotation Settings | 4-18 |
| Envelope Printing | 4-19 |
| Document/Envelope Printing | 4-20 |
| Duplex Printing | 4-21 |
| Other Printer Commands | 4-23 |
| HP Line Printer | 4-24 |
| Matrix/Specialty Printer Operation | 4-24 |
| IBM Matrix Printer Emulations | 4-24 |
| Character Set | 4-25 |
| Print Quality | 4-25 |
| Pitch Control | 4-26 |
| Graphics Printing | 4-26 |
| Truncate/Wrap | 4-26 |
| True 15 CPI | 4-27 |
| Generic Mode | 4-27 |
| 5 ADVANCED FEATURES | 5-1 |
| Command Pass-Thru™ | 5-1 |
| User Defined Strings | 5-2 |
| User Defined Fonts (HP PCL only) | 5-3 |
| Color Printing | 5-3 |
| Printing Bar Codes | 5-6 |
| Overview and Examples | 5-11 |
| I-O Graphics Language™ | 5-18 |
| I-O Graphics Language™ Overview | 5-19 |
| Helpful Hints | 5-22 |
| Basic Description | 5-23 |
| I-O Graphic Language™ (IOGL) in Action | 5-32 |
| General Steps | 5-32 |
| Tutorial | 5-33 |
| X and Y-Axes | 5-37 |
| Labels/Title/Subtitle/Legend | 5-38 |
| Linking Graphical Output to a Host Application | 5-39 |
| Printing Images From The Host | 5-39 |

TABLE OF CONTENTS

6 PROBLEM RESOLUTION6-1
 Interface Self-Test6-1
 EBCDIC Hex Dump6-3
 ASCII Hex Dump6-4
 Self-Diagnostics6-4
 Problem Resolution Guide6-6

APPENDICES

- Appendix A - Font (FGID) Reference for PCL Compatible Printers
- Appendix B - Resident Scalable Font Numbers
- Appendix C - Character Sets
- Appendix D - Serial Port Specifications
- Appendix E - Parallel Port Specifications
- Appendix F - Transferring Power to Pin 18

WARRANTY INFORMATION

United StatesW-1
 Customer On-Site Repair PolicyW-3
InternationalW-5
 Return-to-Depot Repair PolicyW-7
EuropeanW-9
 Customer On-Site Exchange Repair PolicyW-11

DECLARATION OF CONFORMITY

TABLE OF CONTENTS

This page left intentionally blank.

1 INTRODUCTION

With the I-O Print Box you have purchased a powerful, yet easy-to-operate external printer interface. The Print Box can easily be set up through on-board DIP switches, Host/PC download commands, or through the I-O setup software. The Print Box was engineered and manufactured by I-O Corporation, the largest third-party supplier of printer interfaces in the world.

The I-O Print Boxes **TxP plus** and **TxS plus** attach virtually any ASCII printer to an AS/400 or System/3X host. They offer reliable emulations of IBM 3812, 4214, 5224, 5225, and 5256 printers. When connected to a laser printer operating in PCL mode, the I-O Print Box allows Computer Output Reduction (COR) and Automatic Print Orientation (APO). In addition, paper can be pulled from several sources, jobs can be printed on both sides of the paper, and a multitude of fonts (printer resident or from optional cartridges) are supported.

The I-O Print Box **TxP plus** comes with a standard parallel sharing port which allows automatic sharing of the attached printer between the host and a PC or LAN. The I-O Print Box **TxS plus** comes with a standard serial sharing port.

The I-O Print Box **TxP lite** attaches virtually any dot matrix printer to an AS/400 or System/3X host. It offers solid IBM 4214, 5224, 5225, and 5256 printer emulations. The I-O Print Box **TxP lite** does not have a parallel sharing port. Its parallel input port is a setup port only.

Description of Front Panels

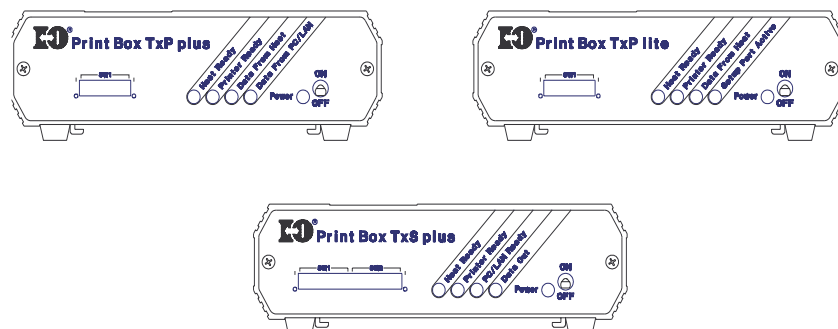

INTRODUCTION

Configuration Switches

The Configuration Switches are used to set the twinax address, output protocol, and to perform the available test and diagnostic functions. While the Print Box TxP models come with only one bank of switches, the Print Box TxS plus comes with two banks of eight switches. The left bank is labeled SW1, the right bank is labeled SW2.

LEDs - The green LED lights indicate the following:

| | |
|-------------------|--|
| Host Ready | Communication lines between the host and the interface are established. |
| Printer Ready | The printer is ready to receive data. |
| PC/LAN Ready | The interface is ready to receive serial data from an attached PC or LAN. |
| Data Out | The interface is currently sending data to the printer. |
| Data From Host | The interface is currently processing data received from the twinax host. |
| Data From PC/LAN | The interface is currently receiving data from an attached PC or LAN. PC download commands or setup instructions sent from the I-O setup software are processed, other data is transmitted to the printer. |
| Setup Port Active | The interface is currently receiving download commands from an attached PC or LAN. This port cannot be used to send data to the printer. |
| Power | The interface is powered on. |

On/Off Switch - The On/Off switch is used to power-on or power-off the interface. Use this switch when asked to cycle power.

About This User's Guide

Since this user's guide covers three I-O Print Box models, not all sections apply to all interface models. The following identifiers are used to signal to the reader that the marked section only applies to a certain model or to certain models:

plus

Only applies to plus version printer interfaces

lite

Only applies to the lite version interface

parallel

Only applies to printer interfaces with parallel output port.

serial

Only applies to printer interfaces with serial output port.

Unpacking

Check the packaging for water or physical damage, and notify the carrier immediately if any damage is evident.

Keep the original packaging in case the interface needs to be moved or shipped.

The package should include the following:

- I-O Print Box TxP plus, I-O Print Box TxS plus, or I-O Print Box TxP lite
- Auto-terminating twinax V-cable
- Transformer (9V AC output)
- Standard parallel cable (TxP plus and TxP lite) or
- Standard serial cable (TxS plus)
- I-O Print Box Tx Quick Setup and User's Guide
- I-O Setup Diskette (3.5")

INTRODUCTION

This page left intentionally blank.

2 INSTALLATION

Before connecting the I-O Print Box to the printer, verify that the printer functions properly by performing a printer self-test. Consult the printer's user's guide for instructions on how to start and evaluate the self-test. If the printer functions properly, proceed with the installation of the I-O interface.

Note: Electrical current from power lines and cables connecting the interface, the printer, and the PC can be hazardous. To minimize the danger, follow the instructions below:

parallel

To install the I-O Print Box TxP plus or TxP lite:

1. Power off the printer and PC (if used) and disconnect the power cord(s).
2. Use the configuration switches located on the interface's front panel to select the desired output protocol and the device address for the interface. Refer to the tables on page 3-2 for switch settings. Make sure the host has been configured for the same device ID and cable address (see "Host Configuration" on page 3-1).
3. Connect the parallel cable from the interface's "Parallel Out" connector to the printer's parallel port.
4. If the sharing port of the TxP plus is used, attach the parallel cable now. Note that a PC or LAN connected to the interface's sharing port should always be powered up when the interface is operating.
5. Connect the transformer from the outlet to the interface's "9V" connector. Connect the power cord(s) to the printer and PC (if used).
6. Power on the Print Box, then the printer. The interface's green LED lights labeled "Power" and "Printer Ready" should be on.
7. Print an interface self-test. First, power off the interface. Then, set configuration switch SW1:8 (far right) to the "I"-position. Power on the interface. After the self-test prints (two or three pages depending on

INSTALLATION

the type of printer), set switch SW1:8 back to the "o" position, then cycle the power one more time.

8. Refer to the self-test print out to determine which configuration parameters need to be altered. Change these parameters by using the I-O setup software or Host/PC download commands.
9. With the Print Box powered off, attach the auto-terminating twinax V-cable to the interface.
10. Connect the twinax host cables to the V-connector. The twinax V-connector is automatically terminated when one cable is attached and automatically cables through when two cables are attached.

serial

To install the I-O Print Box TxS plus:

1. Power off the printer and the PC (if used), and disconnect the power cable(s).
2. Use the configuration switches located on the interface's front panel to select the desired output protocol, the device address, and the serial output parameters for the interface. Refer to the tables on page 3-2 for switch settings. Make sure the host has been configured for the same device ID and cable address (see "Host Configuration" on page 3-1).
3. Connect the serial cable from the interface's "Serial Out" connector to the printer's serial port.
4. If the sharing port is used, attach a second serial cable to the interface's "Serial In" port. Note that a PC or LAN connected to the interface's sharing port should always be powered up when the interface is operating. In addition, the PC/LAN and the interface must be using the same serial parameters. Refer to the section "Printer Sharing" on page 4-1 for more information.
5. Connect the transformer from the outlet to the interface's "9V" connector. Connect the power cord(s) to the printer and PC (if used).

INSTALLATION

6. Power on the Print Box, then the printer. The interface's green LED lights labeled "Power" and "Printer Ready" should be lit. If the sharing port is used and handshaking requirements are met the LED labeled "PC/LAN Ready" should also be on.
7. Print an interface self-test. First, power off the interface. Then, set configuration switch SW1:8 (far right of the first switch bank) to the "I"-position. (If you are operating a label printer, put the printer in ASCII hex dump mode. Then power on the interface. If the label printer starts printing the interface has passed the self-test. To obtain a print out of the current settings, connect the interface to a laser or dot-matrix printer.) Power on the interface. After the two-page self-test prints, set switch SW1:8 back to the "o" position, then cycle the power one more time.
8. Refer to the self-test printout to determine which configuration parameters need to be altered. Change these parameters by using the I-O Setup Software or Host/PC download commands. Refer to the Configuration section for further information.
9. With the Print Box powered off, attach the auto-terminating twinax V-cable to the interface's "Twinax In" port.
10. Connect the twinax host cable(s) to the V-connector. The twinax V-connector is automatically terminated when one cable is attached and automatically cables through when two cables are attached.

Sample self-test printouts for the different I-O Print Box models are shown on the following pages. The printout you obtain may differ from the displayed samples, since only the configuration parameters associated with the active output protocol (e.g. HP PCL, IBM PPDS, etc.) and the IBM printer emulation (e.g. IBM 3812-1, 4214, etc.) are printed. The second page of the self-test printout is the same for all Print Box models.

INSTALLATION

Power On/Off Sequence

Follow the power on and off sequences exactly, or the print output may be garbled.

To power on:

1. Turn on the interface.
2. Turn on the printer.

To power off:

1. Turn off the printer.
2. Turn off the interface.

INSTALLATION

Self-Test Printout - TxP plus

PARALLEL TWINAX INTERFACE
COPYRIGHT (c) 1995 SDE CORP.
SOFTWARE VERSION 1.00

RAM OK

ROM OK

Address : 0
Output Printer Protocol : HP-PCL 3812

#01 - Alt. CPT Start Delimiters : - 50 6C
#02 - Alt. CPT End Delimiters : - 50 6C
#03 - Host Port Timeout : 08 - seconds
#05 - Host Language : 01 - U.S./Canada
#07 - Print Orientation : 0 - COR/Host override allowed
#08 - Auto Print Orientation : 1 - On
#09 - Paper Size : 0 - Host Selected
#10 - True LPI : 0 - Compress LPI
#13 - Paper Drawer 1 : 1 - Tray 1
#14 - Paper Drawer 2 : 4 - Tray 4
#15 - Paper Drawer 3 : 5 - Tray 5
#16 - Override Format Commands : 0 - No Overrides
#17 - Character Set : 1 - Code Page 850
#18 - Starting Vertical Position : 00
#19 - Starting Horizontal Position : 00
#20 - Star Panel Overdrive : 0 - Inactive
#30 - Paper Drawer 4 : 1 - Tray 1
#31 - Paper Drawer 5 : 1 - Tray 1
#32 - 11 X 17 (A3) : 0 - Off
#33 - Duplexing : 0 - Off
#50 - Sharing Port Timeout : 08 - seconds

#11 - Host Port Initialization:

#56 - Parallel Port Initialization:

#04 - User Defined Strings:

U0:
U1:
U2:
U3:
U4:
U5:
U6:
U7:
U8:
U9:

INSTALLATION

Self-Test Printout - TxP lite

PARALLEL TWINAX INTERFACE
FOR DOT-MATRIX PRINTERS
COPYRIGHT (c) 1995 SDE CORP.
SOFTWARE VERSION 1.00

RAM OK
ROM OK

Address : .0
Output Printer Protocol : .Generic

#01 - Alt. CPT Start Delimiters : - 50 6C
#02 - Alt. CPT End Delimiters : - 50 6C
#05 - Host Language : .01 - U.S./Canada
#16 - Override Format Commands : .0 - No Overrides
#17 - Character Set : .1 - Code Page 850
#20 - Star Panel Overdrive : .0 - Inactive
#24 - IBM Printer Emulated : .0 - 5256
#25 - IBM Motion Commands : .0 - Use FF (when possible)
#26 - Truncate/Wrap : .0 - Wrap beyond 8"

#11 - Port Initialization:

#84 - 6 LPI String:
#85 - 8 LPI String:
#86 - 10 CPI String:
#87 - 15 CPI String:

#04 - User Defined Strings:

U0:
U1:
U2:
U3:
U4:
U5:
U6:
U7:
U8:
U9:

INSTALLATION

Self-Test Printout - TxS plus

SERIAL TWINAX INTERFACE
COPYRIGHT (c) 1995 SDE CORP.
SOFTWARE VERSION 1.00

RAM OK
ROM OK

Address: 0
Output Printer Protocol I-O 8215 Emulation
Serial Out Baud Rate 9600 Baud
Serial Out Word Length 8 Bits
Serial Out Stop Bits 1 Bit
Serial Out Parity None

#03 - Twinax Port Timeout 08 - seconds
#20 - Star Panel Overdrive 0 - Inactive
#24 - IBM Printer Emulated 0 - 5224
#25 - IBM Motion Commands 0 - FF (when possible)
#44 - Command Pass-Thru 0 - Enabled
#50 - Sharing Port Timeout 08 - seconds
#76 - Serial In Baud Rate 2 - 9600 Baud
#77 - Serial In Word Length. 8 - 8 Bits
#78 - Serial In Stop Bits 1 - 1 Bit
#79 - Serial In Parity None

#11 - Host Port Initialization:

#58 - Serial Port Initialization:

#84 - 6 LPI String:

#85 - 8 LPI String:

#86 - 10 CPI String:

#87 - 15 CPI String:

#04 - User Defined Strings:
U0:
U1:
U2:
U3:
U4:
U5:
U6:
U7:
U8:
U9:

INSTALLATION

Page 2 of Self-Test Printouts

#21 - User Defined Fonts:

- 0:
- 1:
- 2:
- 3:
- 4:
- 5:
- 6:
- 7:
- 8:
- 9:

EBCDIC to ASCII Translate Table

| | | | | | | | | | | | | | |
|----|----|----|----|----|----|----|----|----|----|----|----|----|---------------------------|
| 40 | 50 | 60 | 70 | 80 | 90 | A0 | B0 | C0 | D0 | E0 | F0 | | |
| 0: | 20 | 26 | 2D | 9B | 9D | F8 | E6 | BD | 7B | 7D | 5C | 30 | &-øø°μÇ{ } \0 |
| 1: | 20 | 82 | 2F | 90 | 61 | 6A | 7E | 9C | 41 | 4A | 00 | 31 | é/Éaj`fAJ-1 |
| 2: | 83 | 88 | B6 | D2 | 62 | 6B | 73 | BE | 42 | 4B | 53 | 32 | âêÂÊbks¥BKS2 |
| 3: | 84 | 89 | 8E | D3 | 63 | 6C | 74 | FA | 43 | 4C | 54 | 33 | âèÀÈclt·CLT3 |
| 4: | 85 | 8A | B7 | D4 | 64 | 6D | 75 | 9F | 44 | 4D | 55 | 34 | àèÀÈdmufDMU4 |
| 5: | A0 | A1 | B5 | D6 | 65 | 6E | 76 | F5 | 45 | 4E | 56 | 35 | áíÁÍenv\$ENV5 |
| 6: | C6 | 8C | C7 | D7 | 66 | 6F | 77 | F4 | 46 | 4F | 57 | 36 | āīĀĪfow¶FOW6 |
| 7: | 86 | 8B | 8F | D8 | 67 | 70 | 78 | AC | 47 | 50 | 58 | 37 | âīĀĪgpx¼GPX7 |
| 8: | 87 | 8D | 80 | DE | 68 | 71 | 79 | AB | 48 | 51 | 59 | 38 | çİÇİhqy¼HQY8 |
| 9: | A4 | E1 | A5 | 60 | 69 | 72 | 7A | F3 | 49 | 52 | 5A | 39 | ñBÑ`irz¼IRZ9 |
| A: | 5B | 5D | 7C | 3A | AE | A6 | AD | AA | 2D | FB | FD | FC | [] : « » ; ; - - 1 2 3 |
| B: | 2E | 24 | 2C | 23 | AF | A7 | A8 | B3 | 93 | 96 | E2 | EA | . \$, # » 2 ç ô ú ô Û |
| C: | 3C | 2A | 25 | 40 | D0 | 91 | D1 | EE | 94 | 81 | 99 | 9A | < * % @ ð æ Ð ` ö ü Ö Û |
| D: | 28 | 29 | 5F | 27 | EC | F7 | ED | F9 | 95 | 97 | E3 | EB | () _ ' ý , Ý " ò ù Ò Û |
| E: | 2B | 3B | 3E | 3D | E8 | 92 | E7 | EF | A2 | A3 | E0 | E9 | + ; > = Þ Æ þ ´ ó ú Ó Û |
| F: | 21 | 5E | 3F | 22 | F1 | CF | A9 | F2 | E4 | 98 | E5 | 20 | ! ^ ? " ± ± ® = õ ý Õ |

Page 3 of Self-Test Printouts

(Only prints when a laser printer is attached.)

Professional Host Print Output through Built-In Graphics Capabilities

Lines

Run Charts

Boxes

Bar Charts

Circles

Pie Charts

Arcs

Text Rotation

Barcodes

To print the box shown on the right, simply embed the following command string in the host data stream:

```
^GB0.3;1500;1500;2100;1800;30
```

graphics element is a box

line width in mm

X start coordinate

Y start coordinate

X end coordinate

Y end coordinate

% of Shading

X axis

Y axis

X and Y coordinates are measured in n/300 inch from the top left hand corner of the printable area of the page.

LOGO INVOICE

Total

The graphical elements shown above can quickly and inexpensively enhance your IBM SCS print output. Vital data can be represented in charts and you can even

Create Electronic Forms

such as invoices, order logs, inventory listings, etc. Check your printer interface Users Guide for more information.

INSTALLATION

This page left intentionally blank.

3 CONFIGURATION

Host Configuration

Before operating the interface in twinax mode, the IBM host must be configured with a device address and device ID for the printer. See your system operator or system manual for details. With the correct address selected, an AS/400 will automatically configure itself according to the active IBM printer emulation on the interface.

1. Make sure you have selected and permanently stored the desired IBM emulation on the interface. This can be done through the setup software or Host/PC download command Z24 (to select emulation) followed by command Z99,0 (to save).
2. Make sure the interface is properly connected to the twinax host and the correct device address is set.
3. Power on the interface. The AS/400 will auto-configure the printer address according to the interface settings.

If you are using a S/3X host you must configure the host manually. The table below shows the recommended emulation and device ID for the different host systems.

| Host System | Printer Used | Emulation | Device ID |
|-----------------------|--|------------------|------------------|
| S/38, S/36 | Laser printer (using HP PCL commands) | 3812 | 5219 |
| S/38, S/36 | Matrix printer (printing NLQ) | 4214 | 4214-2 |
| S/38, S/36, (S/34) | Matrix printer | 5224 | 5224 (2P) |
| S/38, S/36, S/34 | Specialty printer (e.g. label printer) | 5256 | 5256 |

Note: Check the device description. Host Print Transform must be turned "Off" in OS/400 V2R3 and later.

CONFIGURATION

Interface Configuration

The I-O Print Box can be configured through the interface's on-board configuration switches, user-friendly PC setup software, or by sending download commands from the host or from a PC/LAN. To ensure proper functioning of the interface you should review all available setup parameters.

Switch Settings

Use the interface's configuration switches to select the twinax address, the output protocol, and to perform the available test and diagnostic functions. The Print Box TxS plus has a second bank of eight switches (referred to as SW2) to change the serial parameters. Use a pointed object, such as a ball point pen, to change the switch settings.

When operating, the interface will only recognize EBCDIC Hex Dump and ASCII Hex Dump settings. All other settings are only read at power up. Whenever one of these settings is changed, remember to cycle power to activate them.

If an invalid switch setting is encountered at power up, all LED lights will blink and the interface cannot operate.

| Twinax Address | SW1:1 | SW1:2 | SW1:3 |
|----------------|-------|-------|-------|
| 0 | o | o | o |
| 1 | o | o | |
| 2 | o | | o |
| 3 | o | | |
| 4 | | o | o |
| 5 | | o | |
| 6 | | | o |

CONFIGURATION

| Output Protocol | SW1:4 | SW1:5 | SW1:6 | SW1:7 |
|---|-------|-------|-------|-------|
| Hewlett-Packard PCL ¹⁾ | o | o | | o |
| Hewlett-Packard PCL (non-PJL) ¹⁾ | o | | o | o |
| IBM Proprinter | o | | o | |
| IBM PPDS (dot-matrix) | o | o | o | o |
| Epson ESC/P2 | o | o | o | |
| Epson DFX+ | o | | | |
| Epson LQ (24-pin) | o | | | o |
| Epson 9-pin (DFX) | | o | o | o |
| Generic | | o | o | |
| Hewlett-Packard LinePrinter ¹⁾ | | o | | o |
| I-O 8215 ¹⁾ | | o | | |

1) This selection is not available with the I-O Print Box TxP lite.

To obtain the default IBM printer emulation associated with the selected output protocol, you should restore factory defaults. Then proceed with the configuration of the interface. Refer to page 3-18 (Host Download Command 24) for more information on IBM printer emulations.

| Tests/Diagnostics | SW1:1 | SW1:2 | SW1:3 | SW1:8 |
|--------------------------|---|-------|-------|-------|
| Twinax Diagnostic | | | | |
| Restore Factory Defaults | | | | o |
| Self-Test | Any setting corresponding to a twinax address 0-6 | | | |
| EBCDIC Hex Dump | | | | |
| Operating Mode | | | | o |

CONFIGURATION

| Tests/Diagnostic | SW1:4 | SW1:5 | SW1:6 | SW1:7 |
|------------------|-------|-------|-------|-------|
| ASCII Hex Dump | | | | |

The first three functions (Twinax Diagnostics, Restore Factory Defaults, Self-Test) are only performed if the configuration switches are set as indicated when the interface is powered up. In the case of the self-test, the interface prints a self-test at power up and then should be powered off. Refer to the Problem Resolution section of this user's guide for more information.

serial

The second (right) bank of switches of the I-O Print Box TxS plus is used to set up the interface for communication with the printer.

| Serial Out Baud Rate | SW2:1 | SW2:2 | SW2:3 |
|----------------------|-------|-------|-------|
| 38,400 | o | o | o |
| 19,200 | o | o | |
| 9,600 | o | | o |
| 4,800 | o | | o |
| 2,400 | | o | o |
| 1,200 | | o | |
| 600 | | | o |
| 300 | | | |

| Serial Out Word Length | SW2:4 |
|------------------------|-------|
| 7 bits | o |
| 8 bits | |

CONFIGURATION

| Serial Out Stop Bits | SW2:5 |
|----------------------|-------|
| 1 Bit | o |
| 2 Bits | |

| Serial Out Parity | SW2:6 | SW2:7 |
|-------------------|-------|-------|
| None | o | o |
| Odd | o | |
| Even | | o |

| XOn/XOff Flow Control | SW2:8 |
|-----------------------|-------|
| Enable XOn/XOff | |
| Disable XOn/XOff | o |

I-O Setup Software

All configuration parameters not already covered through configuration switches can be changed through the setup software. Before configuring the Print Box you should print a self-test. A self-test printout shows all active configuration settings. Refer to this printout to determine which parameters may need to be changed through the setup software. To run this software, attach a PC or LAN printer server to the parallel sharing (TxP plus), PC setup (TxP lite) port, or to the serial sharing port (TxS plus).

Note: A printer must be connected to the interface and in "Ready" mode in order for the interface to receive data from any of the ports.

Start your PC and go to the DOS prompt. Insert the I-O setup software into the PC. At the DOS prompt type **A:setup** and press **Enter**. The I-O setup program will appear on the screen. Follow the instructions shown on the screen.

CONFIGURATION

Host/PC Download Commands

By sending download commands from the Host/PC to the I-O Print Box, you can change all configuration parameters not already covered through the configuration switches.

Most Host/PC download commands are placed in a Host/PC document or on the screen. Regardless of whether the incoming print job is a screen print, a spread sheet or a word-processing document created on either the host or PC, the interface will recognize the Host/PC download command.

The command itself will not be printed if it was entered correctly. If any part of the command is printed, the interface did not recognize the command because of a problem in the format. Check the syntax of the command and send the command again.

Note: Any data received through the PC setup port of the I-O Print Box TxP lite will not print. Therefore, the above mentioned check does not apply to download commands received through the PC setup port.

Most Host/PC download commands sent to the I-O Print Box take effect immediately and stay only in the interface's active memory. To save the changed configuration beyond a power off, Host/PC download command Z99,0 must be sent.

Tip: Save the Host/PC download commands in a separate file. If you need to re-configure the I-O Print Box at a later time, or if you need to configure more than one I-O Print Box, just "print" the file containing the Host/PC download commands.

Take the following steps to enter a host download command.

1. Type the Command Pass-Thru delimiter **&%** (or alternate CPT start delimiter) in the document at the point where the command is to take effect.
2. Type an upper case "Z".

CONFIGURATION

3. Type the command number for the command to be used, as shown in the table. Always use two digits for the command number (i.e. &%Z05,)
4. Type a comma.
5. Type the value representing the desired selection. No spaces are allowed. A space or invalid character in a command causes the interface to ignore the command and resume printing from the point the error occurred.
6. A space or control character (i.e., NL, FF, CR, LF) signals the end of the download command.
7. Multiple commands can be chained together by using a slash (/) or back slash (\) to separate the commands (no spaces allowed). For example, to set the Default Print Quality (Command 22) to NLQ (Value 1), Draft Printing (Command 23) to Fast Draft (Option 1), and the Wrap/Truncate Text selection (Command 26) to Truncate (Option 1), type:

&%Z22,1/Z23,1/Z26,1

Host/PC Download Command Overview

The following table shows the Host/PC Download commands for the I-O Print Box and corresponding command numbers in alphabetical order:

CONFIGURATION

| Host/PC Download Command | Command Number |
|--|----------------|
| 10 CPI String | 86 |
| 15 CPI String | 87 |
| 15 CPI Printing (Proprinter Mode only) | 28 |
| 6 LPI String | 84 |
| 8 LPI String | 85 |
| 11" x 17" / A3 Printing | 32 |
| Alternate CPT Start Delimiter | 01 |
| Alternate CPT End Delimiter | 02 |
| Automatic Print Orientation (plus models only) | 08 |
| Character Set | 17 |
| Command Pass-Thru (plus models only) | 44 |
| Default Print Quality | 22 |
| Draft Printing | 23 |
| Duplex Printing (plus models only) | 33 |
| Host Language | 05 |
| Host Port Timeout (plus models only) | 03 |
| Host Port Initialization (plus models only) | 11 |
| IBM Printer Emulated | 24 |
| IBM Motion Commands | 25 |
| Override Format Commands | 16 |
| Paper Bin Selection | 09 |
| Paper Drawer 1 (plus models only) | 13 |
| Paper Drawer 2 (plus models only) | 14 |
| Paper Drawer 3 (plus models only) | 15 |

CONFIGURATION

| Host/PC Download Command | Command Number |
|---|----------------|
| Paper Drawer 4 (plus models only) | 30 |
| Paper Drawer 5 (plus models only) | 31 |
| Paper Size (plus models only) | 09 |
| Parallel Port Initialization String (TxP plus only) | 56 |
| Print Orientation (plus models only) | 07 |
| Print Setup Parameters (plus models only) | 98 |
| Restore Factory Defaults | 98 |
| Restore Previously Saved Configuration | 98 |
| Save All Current Settings | 99 |
| Serial In Baud Rate (TxS plus only) | 76 |
| Serial In Word Length (TxS plus only) | 77 |
| Serial In Stop Bits (TxS plus only) | 78 |
| Serial In Parity (TxS plus only) | 79 |
| Serial Port Initialization String (TxS plus only) | 58 |
| Sharing Port Timeout (plus models only) | 50 |
| Star Panel Overdrive | 20 |
| Starting Horizontal Position (plus models only) | 19 |
| Starting Vertical Position (plus models only) | 18 |
| True LPI (plus models only) | 04 |
| Truncate/Wrap | 26 |
| User Defined Fonts | 21 |
| User Defined Strings | 04 |
| Wrap/Truncate | 26 |

CONFIGURATION

Configuration Options

Asterisks (*) identify factory default settings. Invalid commands are ignored. The last valid setting will be unchanged.

COMMAND 01: ALTERNATE CPT START DELIMITER

Creates an alternate Command Pass-Thru (CPT) start delimiter. This delimiter is also an alternate Host/PC download delimiter. It may be one or two characters long. The first character may be any printable character other than "&." Only one alternate CPT start delimiter is allowed. The default "&%" will always be recognized as CPT delimiter.

| <u>VALUE</u> | <u>DESCRIPTION</u> |
|----------------|---------------------------------------|
| New characters | Alternate CPT start delimiter |
| Two spaces | Deletes alternate CPT start delimiter |

Example: &%Z01,#* creates the alternate CPT start delimiter #*.

COMMAND 02: ALTERNATE CPT END DELIMITER

Creates an alternate CPT end delimiter as above. This delimiter cannot be used as an alternate Host/PC download delimiter.

| <u>VALUE</u> | <u>DESCRIPTION</u> |
|----------------|---------------------------------|
| New characters | Alternate CPT end delimiter |
| Two spaces | Deletes the alternate delimiter |



COMMAND 03: HOST PORT TIMEOUT

Selects a new timeout value for the interface to wait for data from the host before allowing the printer to honor PC print jobs. Each digit equals one second.

| <u>VALUE</u> | <u>DESCRIPTION</u> |
|--------------|------------------------|
| 04 to 60 | Sets new timeout value |
| *8 | |

Example: &%Z03,05 selects 5 seconds.

CONFIGURATION

COMMAND 04: USER-DEFINED STRINGS

Creates up to ten user-defined strings to send to the printer later. Place the hex codes representing the desired printer command inside the parentheses (up to 25 hex pairs). Spaces between hex pairs are allowed to aid in readability. Consult the printer's user's guide for proper hex codes. The user-defined string is stored in the interface's memory under the selected value number (0 to 9). To activate the command, place a `&%UX` (where X is the value number) in the document.

| <u>VALUE</u> | <u>DESCRIPTION</u> |
|--------------------|--|
| 0 to 9 (hex codes) | Assigns the hex command to a one digit delimiter (0-9) |
| 0 to 9() | Deletes the specified user-defined string from memory. |

Example: `&%Z04,3(1B26643044)` creates a user-defined string for a Lexmark 4039 printer to start underlining as command 3. The string is represented by the value 3. To use this function, place `&%U3` in the document.

COMMAND 05: HOST LANGUAGE

Selects the host language to be used by the twinax host, when the command "Use Default Language" is received.

| <u>VALUE</u> | <u>DESCRIPTION</u> |
|--------------|--------------------|
| 00 | Multinational |
| *01 | USA/Canada |
| 02 | Austria/Germany |
| 03 | Belgium |
| 04 | Brazil |
| 05 | Canada/French |
| 06 | Denmark/Norway |
| 07 | Finland/Sweden |
| 08 | France |
| 09 | Italy |
| 10 | Japan |
| 11 | Japan (U.S.) |
| 12 | Portugal |

CONFIGURATION

| | |
|----|------------------|
| 13 | Spain |
| 14 | Spanish speaking |
| 15 | United Kingdom |

Example: &%Z05,00 selects the multinational character set.

plus

COMMAND 07: PRINT ORIENTATION

HP PCL and HP LinePrinter only. Determines the print orientation if it is not already determined through the host or the interface's APO feature (Command 08).

| <u>VALUE</u> | <u>DESCRIPTION</u> |
|--------------|--|
| *0 | COR, but host override through Print Quality setting allowed |
| 1 | Portrait |
| 2 | Landscape |
| 3 | COR |

Note: Refer to page 4-12 for a detailed description regarding print orientation.

Example: &%Z07,2 selects landscape

plus

COMMAND 08: AUTOMATIC PRINT ORIENTATION

HP PCL only. Selects or deselects Automatic Print Orientation (APO).

| <u>VALUE</u> | <u>DESCRIPTION</u> |
|--------------|--------------------|
| 0 | APO Off |
| *1 | APO On |

Note: Refer to page 4-14 for a detailed description regarding APO.

Example: &%Z08,1 turns the Automatic Print Orientation on.

CONFIGURATION

plus

COMMAND 09: PAPER SIZE/BIN SELECTION

Selects the paper size if the printer attached is a laser. If the printer attached is an Epson DFX dot-matrix printer with multiple-bins for different input paper paths, this command will either allow the bin commands to be passed onto the printer, or suppress those commands.

| <u>VALUE</u> | <u>PCL LASER PRINTER</u> | <u>EPSON DFX DOT-MATRIX PRINTERS</u> |
|--------------|---|--|
| *0 | Paper size specified by host software | Bin commands are sent to the printer |
| 1 | A4 size paper | No bin commands are sent to the printer |
| 2 | Paper size selected through Printer's front panel | |

Example: &%Z09,1 selects A4 size paper for a laser printer.
&%Z09,1 tells the interface not to send any bin commands to an Epson DFX dot-matrix printer.

Note: Only the plus models will support the values for the PCL laser printers.

plus

COMMAND 10: TRUE LPI

HP PCL only. Selects compressed or true LPI (lines per inch) printing

| <u>VALUE</u> | <u>DESCRIPTION</u> |
|--------------|--|
| *0 | No, compressed LPI |
| 1 | Yes, true LPI |
| 2 | Xpoint Twinax Controller Compatibility |

Example: &%Z10,1 selects true LPI.

Note: If you are using one of the popular Electronic Forms packages from companies like XPoint, Eclipse, Formula One, or others, use the true LPI selection. Use the last selection only if you want to run the software setup for the XPoint Twinax Controller.

CONFIGURATION

plus

COMMAND 11: HOST PORT INITIALIZATION STRING

Enters a twinax port initialization string (in hex code, up to 25 pairs) that is sent to the printer after the interface has reconfigured the printer for host printing. Consult the printer's user's guide for the available commands and proper hex values.

| <u>VALUE</u> | <u>DESCRIPTION</u> |
|---------------|---|
| 0 (hex codes) | Stores the hex command as a host port initialization string |

Example: &%Z11,0(1B266C3844) sets LPI to 8 LPI on a Lexmark 4039 laser printer.

plus

COMMAND 13: PAPER DRAWER 1 COMMAND

HP PCL only. Matches the host's Paper Drawer 1 command with a physical paper source from the printer. When the host sends a command to the printer to feed from paper drawer 1, the printer will feed from the paper source assigned to paper drawer 1. Consult the printer's user's guide for the available paper sources and respective numbers. Refer to page 4-9 of this User's Guide for more information.

| <u>VALUE</u> | <u>DESCRIPTION</u> |
|--------------|--|
| 01 to 07 | Paper sources available on the printer |
| *01 | Default |

Example: &%Z13,05 assigns the optional 500-sheet cassette on an HP LaserJet 4 Plus to the host's paper drawer 1 command.

plus

COMMAND 14: PAPER DRAWER 2 COMMAND

HP PCL only. Matches the host's Paper Drawer 2 command with a physical paper source from the printer. When the host sends a command to the printer to feed from paper drawer 2, the printer will feed from the paper source assigned to paper drawer 2. Consult the printer's user's guide for the available paper sources and respective numbers. Refer to page 4-9 of this User's Guide for more information.

CONFIGURATION

| <u>VALUE</u> | <u>DESCRIPTION</u> |
|--------------|--|
| 01 to 07 | Paper sources available on the printer |
| *04 | Default |

Example: &%Z14,05 assigns the optional 500-sheet cassette on an HP LaserJet 4 Plus to the host's paper drawer 2 command.

plus

COMMAND 15: PAPER DRAWER 3 COMMAND

HP PCL only. Matches the host's Paper Drawer 3 command with a physical paper source from the printer. When the host sends a command to the printer to feed from paper drawer 3, the printer will feed from the paper source assigned to paper drawer 3. Consult the printer's user's guide for the available paper sources and respective numbers. Refer to page 4-9 of this User's Guide for more information.

| <u>VALUE</u> | <u>DESCRIPTION</u> |
|--------------|---|
| 01 to 07 | Paper sources available on the printer. |
| *05 | Default |

Example: %Z15,04 assigns the multi-purpose tray on an HP LaserJet 4 Plus to the host's paper drawer 3 command.

COMMAND 16: OVERRIDE FORMAT COMMANDS

Allow operator settings on the printer's front panel to override format commands coming from the host.

| <u>VALUE</u> | <u>DESCRIPTION</u> |
|--------------|---|
| *0 | No, do not override IBM format commands |
| 1 | Yes, override all IBM format commands |
| 2 | Yes, override NLQ commands |
| 3 | Yes, override CPI commands |

Example: &%Z16,1 enables the front panel to override all IBM format commands

CONFIGURATION

COMMAND 17: CHARACTER SET

Selects which character set will be used when both are available for the desired font. The character set selected is used as the underlying ASCII table for EBCDIC to ASCII translations. Consult the printer's user's guide to verify that the printer also uses the font and character set selected.

| <u>VALUE</u> | <u>DESCRIPTION</u> |
|--------------|--------------------|
| 0 | Roman 8 |
| *1 | CP 850 |
| 2 | CP 437 |
| 3 | CP 858 # |
| 4 | Latin 1 Euro # |

Example: &%Z17,4 selects the Latin 1 character set which includes the Euro symbol.

Note: # The Euro symbol is supported in code page 858 for dot-matrix printers, and in the Windows 3.1 Latin 1 character set for laser printers.

plus

COMMAND 18: STARTING VERTICAL POSITION

HP PCL only. Adjusts the upper left corner starting vertical position for printing on the page in 1/60 of an inch.

| <u>VALUE</u> | <u>DESCRIPTION</u> |
|--------------|--|
| -127 to 127 | Adjustment of vertical position in 1/60 of an inch |
| *0 | Default |

Example: &%Z18,-20 moves printing on the page up 1/3 inch or 2 lines at 6 LPI

plus

COMMAND 19: STARTING HORIZONTAL POSITION

HP PCL only. Adjusts the upper left corner starting horizontal position for printing on the page in 1/60 of an inch.

CONFIGURATION

| <u>VALUE</u> | <u>DESCRIPTION</u> |
|--------------|--------------------|
| -127 to 127 | |
| *0 | Default |

Example: &%Z19,12 moves printing on the page 1/5 inch right or 2 characters at 10 CPI

COMMAND 20: STAR PANEL OVERDRIVE

Activates star panel overdrive to add to the signal strength when problems occur with passive star panels.

| <u>VALUE</u> | <u>DESCRIPTION</u> |
|--------------|--------------------|
| *0 | Overdrive inactive |
| 1 | Overdrive active |

Example: &%Z20,1 activates star panel overdrive

Note: Do not activate the star panel overdrive when using twinax cabling.

plus

COMMAND 21: USER FONT STRINGS

HP PCL only. Assigns a font ID to a font. The first number (0-9) is one of 10 available strings, the second number (0-65535) is the host font number. The characters shown in parentheses are sent to the printer when the host font number is received. Refer to the printer's user's guide or the documentation accompanying the font cartridge for a list of available fonts and their respective strings. Use the < character to indicate the ESCape character.

| <u>VALUE</u> | <u>DESCRIPTION</u> |
|---------------|---|
| 0-9, | One of ten available strings |
| 0-65535 | Host font number |
| (ASCII Char.) | Up to 25 ASCII characters representing the desired font |

Example: &%Z21,3,12345(<(12U<(s0p12h10v1s3b6T)

This selects the third font string to be font #12345 and selects for a Lexmark 4039 printer:

CONFIGURATION

12U = code page 850
0p = fixed spacing
12h = 12 pitch
10v = 10 point
1s = italic
3b = bold
6T = letter gothic

COMMAND 22: DEFAULT PRINT QUALITY

Non-HP PCL only. Defines the print quality when the host sends "default print quality" commands.

| <u>VALUE</u> | <u>DESCRIPTION</u> |
|--------------|--------------------|
| *0 | Draft |
| 1 | NLQ |

Example: &%Z22,1 sets NLQ printing as the default

COMMAND 23: DRAFT PRINTING

Non-HP PCL only. Selects the Draft Printing mode when a draft print command comes from the host or from the interface.

| <u>VALUE</u> | <u>DESCRIPTION</u> |
|--------------|--------------------|
| *0 | Normal draft |
| 1 | Fast draft |

Example: &%Z23,1 sets the printer to print fast draft

COMMAND 24: IBM PRINTER EMULATION

Selects the IBM printer emulation. The IBM printer emulation is closely related to the selected output protocol (DIP switches, see page 3-3). The table below summarizes this relationship. When changing the output protocol the interface only loads the default IBM printer emulation if the active IBM emulation is invalid. **To obtain the default IBM printer emulation, you need to restore factory defaults.**

CONFIGURATION

Example: Your interface is set to the Generic output protocol and IBM 5256 printer emulation. You now switch to the I-O 8215 output protocol. Since the currently active IBM 5256 printer emulation is valid (see table below), the interface will honor this emulation and not change. Had you selected the HP line printer emulation, the IBM 5256 printer emulation would not be a valid selection. The interface would have switched to the default IBM 5224 printer emulation.

| Output Protocol | Default IBM Printer Emulation | Other Valid Printer Emulations |
|---|-------------------------------|--------------------------------|
| Hewlett-Packard PCL ¹⁾ | 3812-1 (SCS) | -- |
| Hewlett-Packard PCL (non-PJL) ¹⁾ | 3812-1 (SCS) | -- |
| IBM Proprinter | 4214 | 5224, 5225, 5256 |
| IBM PPDS | 4214 | 5224, 5225, 5256 |
| Epson ESC/P2 | 4214 | 5224, 5225, 5256 |
| Epson DFX+ | 4214 | 5224, 5225, 5256 |
| Epson LQ (24-pin) | 4214 | 5224, 5225, 5256 |
| Epson 9-pin (DFX) | 4214 | 5224, 5225, 5256 |
| Generic | 5256 | 5224, 5225 |
| Hewlett-Packard Line Printer ¹⁾ | 5224 | -- |
| I-O 8215 ¹⁾ | 5224 | 5225, 5256 |

¹⁾ Not available on TxP Lite models.

| <u>VALUE</u> | <u>DESCRIPTION</u> |
|--------------|--------------------|
| 0 | 5256 Model 3 |
| 1 | 5224 Model 1 |
| 2 | 5225 Model 1 |
| *3 | 4214 Model 2 |

CONFIGURATION

Example: &%Z24,2 sets the active printer emulation to 5225 Model 1

Note: An AS/400 will auto configure when the Print Box is powered on. Therefore, you should save the new IBM emulation and then cycle the power on the interface to communicate the new emulation to the AS/400.

COMMAND 25: IBM MOTION COMMAND

Non-HP PCL only: Manipulates the IBM motion command.

| <u>VALUE</u> | <u>DESCRIPTION</u> |
|--------------|-------------------------------|
| *0 | Use FF (when possible) |
| 1 | Substitute multiple LF for FF |
| 2 | Suppress FF |
| 3 | Suppress CR, LF and FF |

Note: The Generic output protocol is strongly recommended when using a selection other than the default.

Example: &%Z25,1 sets the interface to count the lines specified through LPI settings and replace FF with multiple LF

COMMAND 26: WRAP/TRUNCATE TEXT

Non-HP PCL only. Sets the printer to wrap or truncate text lines longer than 8 inches.

| <u>VALUE</u> | <u>DESCRIPTION</u> |
|--------------|---------------------------|
| *0 | Wrap text |
| 1 | Truncate text at 8 inches |

Example: &%Z26,1 Sets the printer to truncate at 8 inches. Text beyond 8 inches will be lost.

CONFIGURATION

COMMAND 28: 15 CPI PRINTING

IBM Proprinter only: Determines how host commands for 15 CPI printing should be executed.

| <u>VALUE</u> | <u>DESCRIPTION</u> |
|--------------|-------------------------------|
| *0 | No, prints 15 CPI as 17.1 CPI |
| 1 | Yes, prints 15 CPI as 15 CPI |

Note: IBM Proprinters cannot print 15 CPI. The I-O Print Box has the ability to "artificially" print 15 CPI by printing 17.1 CPI and adjusting the spacing through insertion of a space in graphics mode. Although this option allows users to effectively print 15 CPI (e.g. when using pre-printed forms) it significantly slows down the printer.

Example: &%Z28,1 Sets the printer interface to "artificially" produce 15 CPI printing.

plus

COMMAND 30: PAPER DRAWER 4 COMMAND

HP PCL only: Matches the host's Paper Drawer 4 command with a physical paper source from the printer. When the host sends a command to the printer to feed from paper drawer 4, the printer will feed from the paper source assigned to paper drawer 4. Consult the printer's user's guide for the available paper sources and respective numbers. Refer to page 4-9 of this User's Guide for more information.

| <u>VALUE</u> | <u>DESCRIPTION</u> |
|--------------|--|
| 01 to 07 | Paper sources available on the printer |
| *01 | Default |

Example: &%Z30,05 assigns the optional 500-sheet cassette on an HP LaserJet 4 Plus to the host's paper drawer 4 command.

CONFIGURATION

plus

COMMAND 31: PAPER DRAWER 5 COMMAND

HP PCL only: Matches the host's Paper Drawer 5 command with a physical paper source from the printer. When the host sends a command to the printer to feed from paper drawer 5, the printer will feed from the paper source assigned to paper drawer 5. Consult the printer's user's guide for the available paper sources and respective numbers. Refer to page 4-9 of this User's Guide for more information.

| <u>VALUE</u> | <u>DESCRIPTION</u> |
|--------------|--|
| 01 to 07 | Paper sources available on the printer |
| *01 | Default |

Example: &%Z31,05 assigns the optional 500-sheet cassette on an HP LaserJet 4 Plus to the host's paper drawer 5 command.

plus

COMMAND 32: 11" x 17" / A3 PRINTING

HP PCL only. Forces the printer to print on 11 x 17 inch or A3 size paper, even when the host sends requests for smaller paper sizes (i.e. letter, legal, A4, Executive). This only applies to printers capable of printing on 11 x 17 inch or A3 size paper (like the HP LaserJet 4V printer).

| <u>VALUE</u> | <u>DESCRIPTION</u> |
|--------------|-------------------------------|
| *0 | 11 x 17 / A3 selection is OFF |
| 1 | 11 x 17 / A3 selection is ON |

Note: With the 11 x 17 / A3 selection ON, the interface's APO feature (if turned ON) will automatically rotate all documents/reports with dimensions of 11 x 17 inches or smaller. To achieve COR in this case, the document/report has to be larger than 11 x 17 inches.

Example: &%Z32,1 Forces printing on large paper. The interface will request the printer to load A3 size paper when the host requests A4 or A3, and 11 x 17 inch paper in all other cases.

plus

COMMAND 33: DUPLEX PRINTING

HP PCL only. Sets the interface to duplexing mode. This applies only when a printer with duplexing capability is attached.

| <u>VALUE</u> | <u>DESCRIPTION</u> |
|--------------|----------------------|
| *0 | Off |
| 1 | Long-edge duplexing |
| 2 | Short-edge duplexing |

Example: &%Z33,2 Instructs the interface to duplex all host print jobs along the short edge of the paper

COMMAND 42: EBCDIC HEX DUMP

After receiving a start command the interface, starting with the next buffer received, sends all host data directly to the printer as hexadecimal printing until the interface is powered off.

| <u>VALUE</u> | <u>DESCRIPTION</u> |
|--------------|-----------------------|
| *0 | No action taken |
| 1 | Start EBCDIC hex dump |

Notes: This command enables the user to print only the section of the document that is in question in buffer hex dump format.

Hex printing starts with the buffer after the start command and stops when the interface is powered off.

Example: &%Z42,1 Starts buffer hex dump printing.

COMMAND 43: ASCII HEX DUMP

After receiving a start command, the interface, starting with the next buffer received, translates all host data into ASCII (from EBCDIC) and then causes the ASCII data to print in hexadecimal form. The ASCII hex dump is performed until the interface is powered off.

CONFIGURATION

| <u>VALUE</u> | <u>DESCRIPTION</u> |
|--------------|----------------------|
| *0 | No action taken |
| 1 | Start ASCII Hex Dump |

Example: &%Z43,1 Starts ASCII hex dump printing.

plus

COMMAND 44: COMMAND PASS-THRU

I-O 8215 Emulation only. Enables or disables Command Pass-Thru (CPT) and host download. When CPT is disabled, the active CPT delimiters are not recognized as flags, but are treated as regular printed characters.

| <u>VALUE</u> | <u>DESCRIPTION</u> |
|--------------|--------------------|
| *0 | CPT enabled |
| 1 | CPT disabled |

Example: &%Z44,1 Disables Command Pass-Thru

Note: Command Z44,1 disables all (i.e., &%Z44,1/Z99,0) subsequent host download commands received by the I-O 8215 emulation. If the user desires to save this setting in permanent memory, Z99,0 must be chained to it. If the user desires to re-enable 8215 host download commands, either restore the factory defaults using the DIP switches, or change the emulation (to Generic, for example) again using the DIP switches, then send the &%Z44,0/Z99,0 command, and finally change back to the 8215 emulation.

plus

COMMAND 50: SHARING PORT TIMEOUT

Selects the sharing port timeout value. This is the time interval before the interface automatically switches from the parallel or serial sharing port to check for data from the host.

| <u>VALUE</u> | <u>DESCRIPTION</u> |
|--------------|--------------------|
| 4 to 60 | 4 to 60 seconds |
| *8 | Default |

Example: &%Z50,10 sets the time interval to 10 seconds.

CONFIGURATION

plus

parallel

COMMAND 56: PARALLEL PORT INITIALIZATION STRING

Allows the user to define a parallel port initialization string of up to 25 ASCII bytes, which is stored in the memory of the interface card. The string is sent to initialize the printer for parallel port printing after host printing has occurred. To aid in readability, a single space is allowed between hex bytes. Refer to page 4-2 for more information.

| <u>VALUE</u> | <u>DESCRIPTION</u> |
|-----------------------|-------------------------|
| 1(up to 25 hex bytes) | Defines the init string |
| 1() | Deletes init string |

Example: &%Z56,1() deletes the hex strings previously defined as parallel port initialization string

serial

COMMAND 58: SERIAL PORT INITIALIZATION STRING

Allows the user to define a serial port initialization string of up to 25 ASCII bytes, which is stored in the memory of the interface card. The string is sent to initialize the printer for serial port printing after host printing has occurred. To aid in readability, a single space is allowed between hex bytes. Refer to page 4-2 for more information.

| <u>VALUE</u> | <u>DESCRIPTION</u> |
|-----------------------|-------------------------|
| 1(up to 25 hex bytes) | Defines the init string |
| 1() | Deletes init string |

Example: &%Z58,1() deletes the hex strings previously defined as serial port initialization string

CONFIGURATION

COMMAND 70: OVERWRITE EBCDIC TRANSLATION TABLE

Custom substitutions defined by this command and stored in permanent memory are written into the EBCDIC to ASCII translation table.

| <u>VALUE</u> | <u>DESCRIPTION</u> |
|--------------|---|
| XX | The EBCDIC character to be changed (in hex) |
| XY | The substitute ASCII character for the EBCDIC character above |

Notes: Previously stored substitutions are automatically changed to the new selection when the same hex location is specified in the EBCDIC table.

Previously stored substitutions are cancelled if an ASCII hex sequence of 00 is specified.

Command Z99,0 must be used to store the substitutions in permanent memory for them to be effective when the printer is next turned on.

The active EBCDIC translation table prints out at the end of the interface self-test summary.

Example: &%Z70,7B,40/Z99,0 prints a 40 ASCII hex (a @ symbol) when the interface receives an EBCDIC 7B (a # symbol). The command is followed by a command Z99,0 which stores the active setup selections in permanent memory.

serial

COMMAND 76: SERIAL-IN BAUD RATE

Selects the Baud Rate for data received at the serial-in port. A new setting will not be effective immediately. To activate the new setting cycle power on the interface.

| <u>VALUE</u> | <u>DESCRIPTION</u> |
|--------------|--------------------|
| 0 | 38,400 baud |
| 1 | 19,200 baud |
| *2 | 9,600 baud |
| 3 | 4,800 baud |

CONFIGURATION

| <u>VALUE</u> | <u>DESCRIPTION</u> |
|--------------|--------------------|
| 4 | 2,400 baud |
| 5 | 1,200 baud |
| 6 | 600 baud |
| 7 | 300 baud |

Example: &%Z76,0 sets the receiving baud rate to 38,400

serial

COMMAND 77: SERIAL-IN WORD LENGTH

Selects the Word Length of data received at the serial-in port. A new setting will not be effective immediately. To activate the new setting cycle power on the interface.

| <u>VALUE</u> | <u>DESCRIPTION</u> |
|--------------|--------------------|
| 7 | 7 Bits |
| *8 | 8 Bits |

Example: &%Z77,7 sets the word length to 7 bits

serial

COMMAND 78: SERIAL-IN STOP BITS

Selects the number of Stop Bits of a data stream received at the serial-in port. A new setting will not be effective immediately. To activate the new setting cycle, power on the interface.

| <u>VALUE</u> | <u>DESCRIPTION</u> |
|--------------|--------------------|
| *1 | 1 Bit |
| 2 | 2 Bits |

Example: &%Z78,2 sets the number of Stop Bits to 2

CONFIGURATION

serial

COMMAND 79: SERIAL-IN PARITY

Selects the Parity of a data stream received at the serial-in port. A new setting will not be effective immediately. To activate the new setting cycle power on the interface.

| <u>VALUE</u> | <u>DESCRIPTION</u> |
|--------------|--------------------|
| *0 | None |
| 1 | Odd |
| 2 | Even |

Example: &%Z79,2 sets the parity to even.

COMMAND 84: 6 LPI STRING

Used with Generic and 8215 output protocol to define the 6 LPI string. This string represents the printer-specific command to set the printer to 6 LPI. Consult the printer's user's guide for the appropriate ASCII hex value representing the 6 LPI command. Whenever the interface receives a 6 LPI command from the host, it sends the string specified through Host/PC download command 84. If no string is specified, it will send the standard 6 LPI command for the active output protocol.

| <u>VALUE</u> | <u>DESCRIPTION</u> |
|-----------------------|--------------------------|
| 1(up to 25 hex bytes) | Defines the 6 LPI string |
| 1() | Deletes the 6 LPI string |

Note: Only characters from 01 to FF are recognized (alphabetic characters must be in upper case). Errors in the hex string will cause the interface to ignore the command and printing will resume at the point the error occurred.

Example: &%Z84,1(1B 32) assigns the 6 LPI command for an Epson LQ-2500 printer (hex value 1B 32) in the interface's memory.

Note: If the active output protocol is generic and no 6 LPI string is specified, the interface will ignore all 6 LPI requests from the host.

CONFIGURATION

COMMAND 85: 8 LPI STRING

Used with Generic and 8215 output protocol to define the 8 LPI string. See Command 84.

| <u>VALUE</u> | <u>DESCRIPTION</u> |
|-----------------------|--------------------------|
| 1(up to 25 hex bytes) | Defines the 8 LPI string |
| 1() | Deletes the 8 LPI string |

Example: &%Z85,1(1B 30) stores the 8 LPI command for an Epson LQ-2500 printer (hex value 1B 30) in the interface's memory.

COMMAND 86: 10 CPI STRING

Used with Generic and 8215 output protocol to define the 10 CPI string. See Command 84.

| <u>VALUE</u> | <u>DESCRIPTION</u> |
|-----------------------|---------------------------|
| 1(up to 25 hex bytes) | Defines the 10 CPI string |
| 1() | Deletes the 10 CPI string |

Example: &%Z86,1(1B 50) stores the 10 CPI command for an Epson LQ-2500 printer (hex value 1B 50) in the interface's memory.

COMMAND 87: 15 CPI STRING

Used with Generic and 8215 output protocol to define the 15 CPI string. See Command 84.

| <u>VALUE</u> | <u>DESCRIPTION</u> |
|-----------------------|---------------------------|
| 1(up to 25 hex bytes) | Defines the 15 CPI string |
| 1() | Deletes the 15 CPI string |

Example: &%Z87,1(1B 67) assigns the 15 CPI command for an Epson LQ-2500 printer (hex value 1B 67) in the interface's memory.

CONFIGURATION

COMMAND 98: RESTORE DEFAULTS OR PRINT CONFIGURATION

Restores the factory default configuration selections, prints out a copy of the active configuration selections, or restores the permanent memory selections to the active setup status.

| <u>VALUE</u> | <u>DESCRIPTION</u> |
|--------------|---|
| 0 | Restores the factory setup |
| 1 | Prints out the active setup selections |
| 2 | Restores the setup selections stored in the permanent memory to active status |

Notes: If a document is printed using temporary host download commands (commands not stored using the Z99,0 command), value 2 will restore the permanent memory selections.

Put a &%Z98,2 at the end of the document to restore the standard setup parameters for the next user of the printer.

The active setup and permanent memory setup selections are the same after a Command Z99,0 or a Command Z98,2 is sent to the printer.

Example: &%Z98,1 Prints out the active setup selections for review

COMMAND 99: SAVE ALL CURRENT SETTINGS

Saves all current settings specified through Host/PC download commands or I-O Setup Software into permanent memory.

| <u>VALUE</u> | <u>DESCRIPTION</u> |
|--------------|---------------------------|
| 0 | Save all current settings |

Example: &%Z99,0 saves all current settings to permanent memory

Note: Most Host/PC download commands sent to the I-O Print Box take effect immediately and stay only in the interface's active memory. To save the changed configuration beyond a power off, Host/PC download command Z99,0 must be sent.

CONFIGURATION

Restoring Factory Defaults

The factory default configuration can be restored by either sending Host/PC Download Command "Z98,0" or by taking the following steps:

1. Power off the printer and the Print Box.
2. Disconnect the host and PC sharing cables from the interface.
3. Set configuration switches SW1:1, SW1:2 and SW1:3 to the "|" position and switch SW1:8 (far right of the first bank of switches) to the "o" position if it is not already there.
4. Power on the Print Box. The factory defaults are restored. The LED lights labeled "Host Ready" and "Printer Ready" will blink continuously, indicating the Print Box is not in operating mode.
5. Power off the Print Box and return configuration switches SW1:1, SW1:2 and SW1:3 to the correct twinax address. Switch SW1:8 should be in the "o" position.

CONFIGURATION

This page left intentionally blank.

4 OPERATION

serial

Serial Printing

By default, the I-O Print Box TxS plus sends data at 96N81 (9,600 baud; parity = none; word length = 8 bits; stop bits = 1). Make sure that the printer and the I-O Print Box are using the same serial parameters. The interface's Serial-Out parameters can be changed using the second (right) bank of switches located on the front panel.

plus

Printer Sharing

The I-O Print Box TxP plus and TxS plus allow the printer to automatically be shared between an attached PC/LAN and an IBM twinax host. Simply connect the PC/LAN printer server to the parallel (TxP plus) or serial (TxS plus) port. The Print Box TxP plus can supply external devices attached to its parallel sharing port with 5V up to 350 mA. See Appendix F for information on how to transfer power to pin 18 of the Print Box.

The interface uses a timeout after each print job before it honors print jobs from another port. At the end of a host print job, the interface waits for the specified Twinax Port Timeout period before it honors data streams coming in through the sharing port. The Twinax Port Timeout period is set through Host/PC download command 03 or through the I-O setup software.

After a parallel or serial print job is completed, the interface will again wait for a period of time before it honors host print jobs. The Sharing Port Timeout is set through Host/PC download command 50 or through the I-O setup software.

By default, the I-O Print Box TxS plus receives PC data at 96N81 (9,600 baud; parity = none; word length = 8 bits; stop bits = 1). Make sure the PC/LAN and the I-O Print Box are using the same serial parameters. In addition, the interface's Serial-In settings should be compatible with its Serial-Out settings. When printing from the PC/LAN, the lowest baud rate (Serial-In/Serial-Out) will determine the print speed. The interface's Serial-In parameters can be changed through Host/PC download commands 76 through 79, or through the I-O setup software.

OPERATION

If the PC print job is sent while a host job is printing, the printer responds as "busy" to the PC print request. The print job can be spooled through a spool program, sent to the printer when the host job is finished or if the PC's printer port is set for infinite retry through the DOS "Configure Printer" command (described in the DOS manual), the print job waits for the printer to be available to receive the data.

The output protocol specified in the interface's configuration (through configuration switch settings) is irrelevant for printing from the shared port. For PC/LAN printing, select the appropriate printer driver on the PC/LAN printer server.

Parallel/Serial Port Initialization

If you want to change the printer's configuration for shared printing (e.g. set it to PostScript mode), use the parallel/serial port initialization string (Host/PC download command 56 or 58). Consult the printer's user's guide for the ASCII hex values representing the desired configuration commands. Then store these commands in the interface's memory using Host/PC download command 56 or 58 or the I-O setup software.

After host printing is completed and before the print job from the shared port is sent to the printer, the interface will send this initialization string to the printer and configure it according to your instructions. However, it is possible that the print job coming through the shared port contains other printer instructions, thus overriding the parallel/serial port initialization string.

Host Printing

Based on the IBM printer emulation selected, you will have access to all the features inherent to the respective IBM printer the interface is emulating.

In addition to the features of the emulated IBM printer, ASCII printers will often have other exciting capabilities which you can take advantage of using I-O's Command Pass-Thru.



Host Port Initialization

After shared printing, the I-O Print Box reconfigures the printer according to the active configuration settings. If you want to further modify the printer configuration (e.g. select a different font for all host printing) take advantage of the host port initialization string. Unlike the Parallel/Serial Port Initialization String, which is usually overridden by commands coming with the PC/LAN print job, the Host Port Initialization String is not sent to the printer until after the interface has reconfigured the printer for host printing. In 3812 emulation, the Init String is sent at the beginning of each printed page. In all other emulations the Init String is sent at the beginning of the first host print job.

Star Panel Overdrive

For installations using twinax cabling, the Star Panel Overdrive option should be set to OFF (Host/PC download command 20).

If problems are experienced with dropping off-line when using a passive star panel and twisted pair cabling, the Star Panel Overdrive should be set to ON. This increases the signal driving capability of the interface.



Laser Printer Operation

The I-O Print Box allows you to emulate an ASCII laser printer as an IBM 3812 printer. This feature-rich emulation is automatically active when you select one of the HP PCL output protocols. You can also run an ASCII laser printer under an IBM 5256 emulation. The following section describes how to access the many features of I-O's emulation of the IBM 3812 printer.

Some earlier laser printers such as the HP LaserJet II and some III series printers, do not support the Print Job Language (PJM). If you are operating such a printer, please select the PCL (non-PJM) protocol through the Print Box's Configuration Switches.

OPERATION

The IBM 3812-1 printer is a laser-type printer which provides font changing capability, plus text rotation and compression features called Automatic Print Orientation (APO) and Computer Output Reduction (COR).

The I-O Print Box's emulation of the 3812 provides bolding, underlining, super and subscripts by recognizing the host commands for these features in the document. A shadow print for bolding is performed automatically on fixed pitch fonts. For proportionally spaced (typographic) fonts, the user must specify the font that is to be printed.

Like an IBM 5219 printer, the 3812 printer is configured with a default font ID on the host. Configure the most commonly used font as the system default, then change as necessary with a printer override or OCL command.

The table below shows which fonts can be used as system defaults for a System/36 or System/38 host.

| Data Processing Fonts - S/36 and S/38 | | | |
|--|----------------------|--------------------|--------------------|
| Typestyle Number | Font ID (Hex) | Pitch (CPI) | Description |
| 05 | 05 | 10 | Presentation |
| 11 | 0B | 10 | Courier |
| 80 | 50 | 12 | Courier |
| 85 | 55 | 12 | Courier |
| 86 | 56 | 12 | Prestige Elite |
| 87 | 57 | 12 | Letter Gothic |
| 91 | 5B | 12 | Courier Italic |
| 158 | 9E | Prop. | Times Roman |
| 159 | 9F | Prop. | Times Roman Bold |
| 160 | A0 | Prop. | Helvetica |
| 162 | A2 | Prop. | Helvetica Italic |
| 223 | DF | 15 | Letter Gothic |



Changing Typestyles

The typestyle number (FGID) selected determines the font to be used. The system operator selects a default typestyle when the printer is configured on the host, however, a word processing program may also have a default typestyle. Since the default typestyle can vary depending on the system setup, ask the system operator if you have questions about the default typestyle on the system.

There are two ways to change typestyles:

- Select a typestyle number within the program or document
- Use Font Change commands in the document

Refer to the program manuals (i.e. OfficeVision/400) to change typestyles in the program. Font Change commands are placed in the document by the user (see below). The four-character font command changes the text to the new font until another Font Change command is entered.

The host does not know that a font change has taken place, and may send the original font number to the printer at the beginning of each page. Therefore, the user may have to put a Font Change command at the beginning of each new page. If the pitch is changed, there may be formatting problems since the host is still formatting each line according to the pitch of the original typestyle number. Text Management/38 does not allow more than one font per line of text, so Font Change commands must be used in such cases.



Font Change Commands

Font Change Commands allow fonts to be changed in the document without using host commands. The commands can be used in either data processing (RPG, Basic programs, etc.) or in word processing documents.

Two types of Font Change Commands exist. Both commands can be placed anywhere within a document. The command consists of the "logical not" (\neg) symbol, and either a capitalized "Q" or "F" followed by the typestyle number corresponding to the desired font. The "^" symbol can be used in place of the " \neg " for non-US applications.

OPERATION

The Font Change Command occupies space in the program or text, however, the command does not print.

-Q - Font change commands using the capital letter "Q" allow the user to access a vast number of printer-resident and optional cartridge fonts. Appendix A shows the tpestyle numbers assigned to the supported fonts. Each tpestyle number describes a particular font with particular attributes. For example, tpestyle number 88 represents Courier Bold, 12 pitch, 10 point.

To change a font, insert a font change command at the beginning of the text where the change is to take place. For example, to bold the word "saves" in the following sentence (assuming the current font is Courier - 12 CPI or pitch, 10 point) type:

Quality -Q88saves-Q85 you time and money.

Here's how the print will look:

Quality **saves** you time and money.

The -Q85 following saves returns the printing back to the original font.

-F - Font change commands using the capital letter "F" allow the user to access all of the scalable fonts available on a printer. Appendix B shows the tpestyle numbers assigned to the supported fonts. Notice that unlike the tpestyle numbers used with -Q commands, the tpestyle numbers in Appendix B describe only the tpestyle of the supported font. The size of the desired font is entered separately in the font change command. For example, to increase the size of the word "saves" in the following sentence to 30 points (assuming the current font is Arial, 12 point), type:

Quality -F6199,30saves-F6199,12 you time and money.

Here's how the print will look:

Quality **saves** you time and money.

OPERATION

The `␣F6199,12` following "saves" returns the printing back to the original font. The numbers following the comma (`␣F6199,30` and `␣F6199,12`) set the point size of a proportional font (such as Arial) and the pitch size of a fixed pitch (such as Courier).

To print fonts that are not already supported through your I-O Print Box, refer to the "User-Defined Fonts" section on page 5-3.

plus

Page Length

The printer prints up to 66 lines at 6 LPI in HP emulation mode (the line spacing will be compressed slightly to fit). The System/36 only allows 65 lines per page. If there are one or two lines at the top of a new page, more lines per page have been formatted than can print.

plus

Paper Size

Configure the printer's setup to the paper size used most. The interface only recognizes these paper sizes:

| | |
|-----------------|------------------------------------|
| Letter Paper | 8.5 x 11 in. (215.9 x 279.4 mm) |
| A4 Paper | 8.27 x 11.69 in. (210 x 297 mm) |
| Legal Paper | 8.5 x 14 in. (215.9 x 355.6 mm) |
| Executive Paper | 7.25 x 10.5 in. (184.2 x 266.7 mm) |
| 11" x 17" Paper | 11 x 17 in (279.4 x 431.8 mm) |
| A3 Paper | 11.69 x 16.54 in (297 x 420 mm) |

If the interface's paper size menu is set to the default "Host selected", it will look for one of the paper sizes mentioned above. If the host sends one of these paper sizes, the interface will instruct the printer to load the respective paper. Otherwise, it will instruct the printer to load the previously used paper size or if the host print job is the first after power up, it will request Letter size paper.

With the "A4 only" selection active, the interface will always instruct the printer to load A4 size paper. If the "Printer selected" option is chosen, the interface will not send any paper requests, and the paper size selected through the printer's front panel will be used.

OPERATION

The following describes how to select legal size paper in DisplayWrite/36 or OfficeVision/400.

1. Press **F20** for "Format options."
2. Select **1** for "Document options" then another **1** for "Document format."
Select **4** for "Page layout/paper options."
3. Scroll to the second screen and enter 8.5 as the paper width and 14 as the paper length. Press ENTER to activate the selection.
4. Press **F12** until the menus have been exited.
5. Print the document.
6. The printer's operator panel displays "Load paper, Tray #, Legal." Install the legal size paper tray into the printer, and the printer will start printing.
7. Press **Continue** on the printer operator panel to print on currently loaded paper and not wait for the size legal tray.

The System/38 only sends margins and other format specifications to a printer when they are different from the previous document or when the printer has been turned off. To choose a different size paper, you must:

1. Select a paper size in the program.
2. Install the correct paper size into the printer.
3. Power the printer off for about five seconds, then power it back on again.
4. Release the job for printing at the printer's controlling workstation.

The line format screens in DisplayWrite/36 (Command 20) also permit you to select "Justify" which aligns the right margin. The interface supports justification for fixed fonts only. For best results using justification, change the zone width to 1 (instead of 6).

**Printing on 11" x 17" or A3 Size Paper**

Some printers, such as the HP LaserJet 4V printer, allow printing on 11" x 17" and A3 size paper. The I-O Print Box automatically recognizes these larger paper sizes (see page 4-7). However, at times it might be advantageous to force the printer to print on 11 x 17 inch or A3 size paper, even when the host sends requests for smaller paper sizes (i.e. letter, legal, A4, Executive). If this is desired, the interface's 11 x 17 (A3) selection should be turned ON through Host/PC download command 32 or through the setup software.

With this selection turned ON, the interface will request the printer to load A3 size paper when the host requests A4 or A3, and 11 x 17 inch paper in all other cases. In addition, the interface's APO feature (if turned ON) will automatically rotate all documents/reports with dimensions of 11 x 17 inches or smaller. To achieve COR in this case, the document/report has to be larger than 11 x 17 inches.

**Paper Drawer Selection**

The IBM host give users the option to select different paper sources when printing. This can be done through the print file or through the Page Layout/Paper Options menu of OfficeVision/400. On the host, these paper sources are called Source Drawer (print file) or Paper Drawer (OfficeVision /400). On the printer, the actual paper sources are usually called trays. The I-O interfaces will map the host's drawer values 1 through 5 to actual paper trays on the attached printer.

The paper drawer feature of the I-O Print Box can be accessed through Host/PC download commands 13, 14, 15, 30 and 31 or through the setup software.

To change the physical tray assigned to the theoretical paper drawer (#1, #2, #3, #4, or #5):

1. Select the paper drawer # through Host/PC download command 13, 14, 15, 30, or 31, or through the setup software;

OPERATION

2. Select the number representing the physical tray listed in the printer's manual.

By changing the paper drawer on the host, up to five different paper sources on the printer can be accessed.

The following table shows the default values and, as an example, lists the corresponding paper tray used for HP LaserJet 4Si and 4 Plus printers:

| Host/PC Download Command | Paper Drawer Number | Default Value | HP4Si Paper Tray | HP4 Plus Paper Tray |
|--------------------------|---------------------|---------------|------------------|---------------------|
| Z13 | 1 | 1 | Upper | Cassette |
| Z14 | 2 | 4 | Lower | MP tray |
| Z15 | 3 | 5 | Not Used | 500-sheet Cassette |
| Z30 | 4 | 1 | Upper | Cassette |
| Z31 | 4 | 1 | Upper | Cassette |

To change the assigned paper tray, type the respective command followed by a comma (,) and the corresponding number of the chosen paper source.

If you have an HP LaserJet 4 Plus connected to the I-O Print Box and the host is requesting paper to be fed through paper drawer #1, the HP printer would, by default, feed from the Paper Cassette. To assign the 500-sheet Cassette to the paper drawer #1 through the setup software, input 5 (from ESC&15H, as found in the printer's user's guide) as the value for Paper Drawer # 1, or send the Host/PC download command Z13,5 to the printer.

plus Paper Output Bin Selection

The I-O Print Box allows you to direct host print jobs to any of the printer's available output bins. The HP LaserJet 5Si, for instance, can be equipped with the optional multi-bin mailbox, which offers 8 additional output bins.

OPERATION

To send a host job to a particular output bin, insert an I-O output command on the first line (line 1, position 1) of the document/report. The I-O output command consists of the “logical not” (¬) or the “carat” (^) symbol followed by a capital letter “O” (for Output) and two digits designating the destination bin. The two digit number corresponds to the printer’s PCL command for the particular output bin.

Once an output bin is selected, all host print jobs will be directed to that output bin. To send host print jobs to another output bin, insert a second I-O command. ¬O00 causes the interface to not send any output instructions to the printer. All print jobs will be directed to the output bin set through the printer’s operator panel.

The I-O output commands are as follows:

| I-O Output Command | Description | PCL Command | HP LJ 5Si Output Bin |
|---------------------------|-----------------------|--------------------|---|
| ¬O00 | Automatic Selection | ESC& 0G | printer’s default bin |
| ¬O01 | Selects bin #1 | ESC& 1G | printer top/face-down bin |
| ¬O02 | Selects bin #2 | ESC& 2G | printer left-face-up bin; not available when the multi-bin mailbox is installed) |
| ¬O03 | Selects bin #3 | ESC& 3G | mailbox face up bin #1 |
| ¬O04 | Selects bin #4 | ESC& 4G | mailbox face down bin #1 |
| ¬O05 | Selects bin #5 | ESC& 5G | mailbox face down bin #2 |
| ¬O06 | Selects bin #6 | ESC& 7G | mailbox face down bin #4 |
| ¬O07 | Selects #7 | ESC& 7G | mailbox face down bin #4 |
| ¬O08 | Selects bin #8 | ESC& 8G | mailbox face down bin #5 |
| ¬O09 | Selects bin #9 | ESC& 9G | mailbox face down bin #6 |
| ¬O10 | Selects bin #10 | ESC& 10G | mailbox face down bin #7 |
| ¬O11 | Selects bin #11 | ESC& 11G | mailbox face down bin #8 |
| ¬O12 to 99 | Selects bin #12 to 99 | not yet assigned | |

OPERATION



Print Orientation

When operating the printer and printer interface in IBM 3812-1 emulation mode, the print orientation of the host document or report is determined by a variety of factors. These factors are in order of their impact on the final print orientation:

1. Page Rotation specified in the print file of a data processing document or in the document format menu of a word processing document.
2. Automatic Print Orientation (APO) setting on the printer interface.
3. Print Orientation setting on printer interface.

As you read the following explanation, refer to the diagram on page 4-13 for an illustration of the print orientation logic.

1. Page Rotation

Degrees of page rotation can be specified through the print file of a data processing document or in the document format menu of a word processing document. See "Changing Page Rotation Settings" below for a description on how to access the print file and the document format menu. The available settings are 0, 90, 180, 270 degrees and AUTO (AS/400 only). The print file also offers DEVD and COR (AS/400 only).

- a. With 0, 90, 180, and 270 degrees you can specify the desired rotation directly from the host.
- b. The COR setting will always print COR, unless the print quality (AS/400 and S/38) is set to NLQ or STD, or Text (S/36) is set to YES. If the page rotation is set to COR and print quality/text is one of the above mentioned settings, the print job will print in portrait in the requested font.
- c. With the DEVD and AUTO settings the host does not influence the print orientation. Rather, the print orientation is determined by the settings on the printer interface.

OPERATION

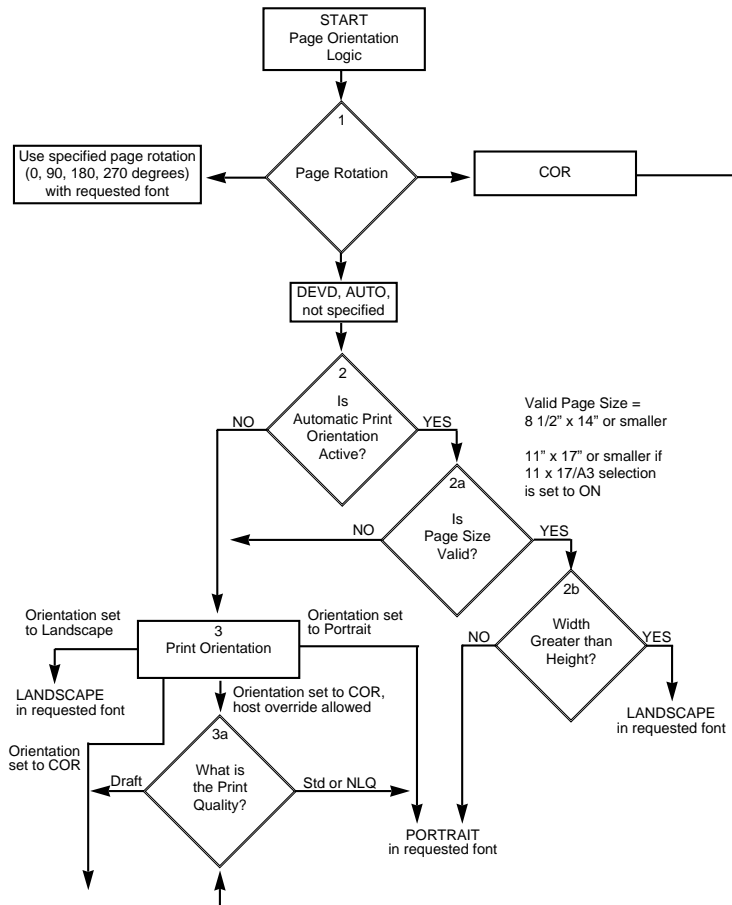

Computer Output Reduction (COR)
 0.5" margins top and left
 LANDSCAPE in reduced font:
 10 pitch font to 13 pitch
 12 pitch font to 15 pitch
 15 pitch font to 20 pitch
 Vertical spacing is:
 6 LPI = 8.7
 8 LPI = 11.6

OPERATION

2. Automatic Print Orientation

If no page rotation was specified on the host, the interface's Automatic Print Orientation (APO) feature is the first setting to determine the final print orientation. This feature automatically rotates print jobs with dimensions of 8.5 x 14 inches or smaller to portrait or landscape orientation.

- a. With the APO feature ON, the interface first checks the dimensions of the host print job. If the print job is larger than 8.5 x 14 inches the interface cannot fit the print job on one page. In this case the orientation of the print job is determined by the print orientation setting on the interface (BLOCK 3).
- b. If the dimensions of the print job are 8.5 x 14 inches or smaller, the interface compares the width to the height and automatically rotates the print job to portrait if the height is larger than the width or landscape if the width is larger than the height.

The dimensions of a word processing document are specified directly through the document format menu. The dimensions of a data processing report are calculated in the following manner:

$$\begin{aligned}\text{Width} &= \text{Page Width (in number of columns)} / \text{CPI} \\ \text{Length} &= \text{Page Length (in number of lines)} / \text{LPI}\end{aligned}$$

3. Print Orientation Settings

The interface's print orientation settings determine the orientation of the host document/report AFTER the host's page rotation setting AND the interface's APO setting have been obeyed.

The available print orientation settings are portrait, landscape, and two COR options. The COR feature rotates documents to landscape orientation and compresses the font as needed to fit the complete document on a standard 8.5"x 14" page. This allows the user to print a report initially designed to fit on 14 7/8" x 11" green bar paper onto a standard letter or legal size page without redesigning the report.

When used together the APO and COR features can be a powerful tool to print host jobs in portrait, landscape, or if required in landscape with reduced font (COR) without user intervention.

OPERATION

The I-O Print Box's first COR option is not a true IBM 3812 emulation. This COR setting was added by I-O to give the user a more straight forward way of obtaining COR. The COR setting ignores print quality settings and always prints COR (unless the host's page rotation or the interface's APO setting determine the print orientation).

- a. The I-O Print Box has a second COR option. This COR option is a true 3812-1 emulation. With certain page rotation settings on the host, the IBM 3812-1 printer allows the user to manipulate the final print orientation through the print quality setting. Note though, that this "override" only applies if the interface's print orientation is set to COR, host override allowed.

OPERATION

The following tables show what page rotation settings can be manipulated through print quality settings and how the combination of page rotation and print quality affects the final print orientation.

| Host System | Page Rotation Setting | Print Quality Setting causing portrait orientation |
|--------------------|------------------------------|---|
| AS/400 | *DEVD (print file) | *NLQ, *STD |
| AS/400 | *AUTO (OfficeVision/400) | NLQ, Text |
| S/36 | not specified | Text - Yes |
| S/38 | not specified | *NLQ, *STD |

COR is defined as printing in landscape orientation, top left margins set at 0.5", with CPI and LPI reduced according to the following tables:

| Host CPI | Reduced to: |
|-----------------|--------------------|
| 10 | 13.3 |
| 12 | 15 |
| 15 | 20 |

| Host LPI | Reduced to: | Maximum Rows (Lines)/Page |
|-----------------|--------------------|----------------------------------|
| 6 | 8.7 | 66 |
| 8 | 11.6 | 88 |

OPERATION

The table on the following page shows the print orientation results desired and recommends a combination of settings required to obtain that result. Most print orientation results can be achieved with different setting combinations. Refer to the diagram and accompanying text on page 4-13.

| | | Printer Interface Setting for | |
|--|--|--|------------------------------|
| Result | Host Setting | APO | Print Orientation |
| <p>Data processing: Print reports with a width of 80 columns or less (at 10 CPI) in portrait <u>AND</u> print reports with a width of 132 (at 10 CPI) or 198 (at 15 CPI) columns in landscape with reduced font (COR)</p> <p>Word processing: Print documents of up to 8.5 x 14 in portrait, 14 x 8.5 in landscape, and anything larger in landscape with reduced font (COR)</p> | <p>Degree of Page Rotation *AUTO</p> <p>Rotate Paper.....=1 (Automatic)</p> | ON | COR |
| Print all reports/documents in landscape with reduced font (COR) | Degree of Page Rotation *AUTO; Rotate Paper=1 (Automatic) | OFF | COR |
| Print all reports/documents in landscape with requested font | Degree of Page Rotation *AUTO; Rotate Paper=1 (Automatic) | OFF | Landscape |
| Print all reports/documents in portrait with requested font | Degree of Page Rotation *AUTO; Rotate Paper=1 (Automatic) | OFF | Portrait |

OPERATION

Changing Page Rotation Settings

Before changing page rotation settings, first verify the current settings. In Office Vision/400 and DisplayWrite/36, page rotation settings can be viewed and changed in the following manner:

1. Press **F20** "Format options."
2. Press **1** "Document options" then ENTER.
3. Press **1** "Document format" then ENTER.
4. Press **4** "Page layout/paper options" then ENTER.
5. Press **Page Down** to scroll to the second screen.
6. Locate "Rotate Paper option."
7. Move the cursor to the currently selected rotation setting and type in the desired selection.

To permanently change the page rotation setting for a data processing report the print file must be changed. This should be done by an MIS staff member, since a changed print file most likely affects many printers. The page rotation setting can be changed temporarily by overriding the print file. The print file must be changed or overridden before the host creates the print job. An overridden print file applies only to print jobs created on the host session that was active when the print file was overridden.

To view the current print file settings, type **CHGPRTF** followed by a space and the name of the print file on the command line of the host. Press **F4**. Do not change any settings unless authorized by the IS director. To change the print file:

1. Type **CHGPRTF** on the command line of the host, and press Enter.
2. Type in the name of the print file to be changed.
3. Press **F10** to display additional parameters.
4. Press **Page Down** to scroll to the fourth screen.

OPERATION

5. Locate "Degree of page rotation" option.
6. Move the cursor to the beginning of the dashed line and enter the desired selection.
7. Press ENTER to activate the selection and exit the print file menu.

To override the print file:

1. Type **OVRPRTF** on the command line of the host, and press Enter.
2. Type the name of the print file to be changed.
3. Press **Page Down** to scroll to the third screen.
4. Locate "Degree of page rotation....." option.
5. Move the cursor to the beginning of dashed line and enter the desired selection.
6. Press ENTER to activate the selection and exit the print file menu.



Envelope Printing

To print envelopes, set the interface to landscape orientation (Host/PC download command 7, Value 2) or activate the Auto Print Orientation feature (Host/PC download command 8, Value 1). The following example shows how to print envelopes from a word processing program, using the printer's optional envelope feeder.

1. Select line **1** as the first typing line.
2. Specify **Envelope** size in the program.
3. Select **Feed Envelope** in the program. Then choose the font desired.
4. Set the left margin to **1**.
5. Type the return address, starting at line 1, column 1.

OPERATION

6. Type the mailing address. The appropriate space for the address will vary with the envelope size. For a Commercial 10 envelope, the address starts at about line 10, column 55.
7. Print the envelope.

The following envelope sizes are supported by the I-O Print Box:

| | |
|------------------|-----------------|
| Monarch | 3 7/8" x 7 1/2" |
| Commercial 10 | 4 1/8" x 9 1/2" |
| International DL | 110 mm x 220 mm |
| International D5 | 162 mm x 229 mm |



Document/Envelope Printing

A letter and an envelope can be printed from DisplayWrite/36 or OfficeVision/400 in the same document by following this procedure:

1. Set the format for the letter and enter the letter file. On the first typing line, press CMD20 for **Format options**.
2. Select **1** for **Document options**, then another **1** for **Document format**. Select **3** for **Typestyle/color**.
3. Select the font ID Number for the letter, such as No. 11, 86, etc., then press ENTER.
4. From the Document Format screen, select option **4** for **Page layout/paper options**. Scroll to the second screen of these options and select a paper size of 8.5 (width) x 11 (length) inches and paper source 1. If the letter is more than one page, select paper source of 1 for the following pages. Press ENTER to return to the **Document format** screen, then CMD 12 to return to the **Document options** screen.
5. Now set up the Alternate Format for the envelope. Select **2** for **Alternate format**, then **3** for **Typestyle/color**. Select the font ID for the envelope and press ENTER to return to the Alternate Format screen.

OPERATION

6. Select **4, Page layout/paper options**. Choose a first typing line of 1, then scroll down to the second screen of the options and choose a paper width of 7.5 (monarch size) or 9.5 (commercial, or #10 size) and a paper length of 4 inches. For a paper source, select 5 for **Envelope Feed**. Press ENTER to return to the Alternate Format screen.
7. Select option **1** for **Margins and Tabs** and make the left margin 1. Press ENTER and CMD3 until you are back in the document.
8. Type in the letter. When done, add in a page end by pressing ALT P.
9. Now load in the Alternate Format for the envelope. To do this, press the CMD5 key, **Goto**, and type in **rf** for **Resetting Format**. Press ENTER. Select option 4 on the Alternate Format screen, **Begin Alternate Format**. Press ENTER.
10. You will now be back in the document, with the Alternate Format. If these instructions have been followed, the cursor will be on the first typing line of 1, with the left margin of 1. Type in the envelope address, and send the file to print. The letter will print out first, followed by the envelope.

Note: The printer may eject a blank page when printing orientation has been changed. If the buffer and ready light remain steady, press the Print/Check button on the printer's operator panel to eject the last page.

Duplex Printing

Some printers can perform both simplex (single sided) and duplex (double-sided) printing. Duplex printing can be accomplished in four ways:

- In OfficeVision/400, select duplex printing in the print options menu for that document (*Type of page printing. . . Double-sided or Double-sided Tumble)
- In OS/400 V2 R3 and later, select duplex printing in the printer file (*Print on both sides. . . *Yes or *Tumble)
- Place I-O Duplexing commands in the document

OPERATION

- Set the interface to duplexing mode through host download command 33.

For most documents, select duplex printing through the host's print options menu (OfficeVision/400) or through the printer file (OS/400 V2 R3). Refer to page 4-16 for a description on how to change the printer file.

I-O duplexing commands are similar to the I-O Font Change commands. These commands are placed on the first line of the document (if not on the first line, the commands do not take effect until the second page of the document). The commands are:

- D0 for simplex printing
- D1 for duplex printing
- D2 for duplex printing (tumble)

When the printer receives a duplexing command, it prints in that mode until another printing command is received. Place the simplex command at the end of the document to return the printer to simplex mode. Envelope printing between documents does not change the printer's mode.

The interface can also be set to duplexing mode through host download command 33. The options are:

- 0 = Simplex
- 1 = Duplex
- 2 = Duplex(tumble) printing

Type `&%Z33,1` or `&%Z33,2` into the document or on the screen and print the document or the screen to set the interface to duplex printing. To return to simplex printing, type and print `&%Z33,0`.

On some duplex printing, if the last page is single sided, the last page may remain in the printer. The form feed light remains on. When the next print job is sent, this page will be ejected. To manually eject the last page, take the printer off-line by pressing the ONLINE button, then press the FORM FEED button to eject the last page. Put the printer back on-line by pressing the ONLINE button once more.



Other Printer Commands

The table below is a summary list of special commands that the laser printer emulation will obey if they are imbedded in a user's document.

| Command | Function |
|---------|---|
| ␣E | Sends an ASCII ESC command to the printer |
| ␣TY | Enables true 6 LPI printing |
| ␣TN | Disables true 6 LPI printing |
| ␣I | Ignores all host formatting commands |
| ␣S | Stops ignoring host formatting commands |

The ␣E command allows an “Esc” command to be sent to the printer to control the printing. Simple “escape” commands eliminate the need for putting in hex codes using Command Pass-Thru. These commands allow use of some of the special features of the laser printer.

Check the printer's manual or any optional technical manual for a description of the feature and the escape commands needed to access the feature. These commands consist of characters which are all found on the IBM twinax keyboard except for the Escape character. For example, ␣E(s3B would begin bold printing on an HP LaserJet printer.

The printer will slightly compress line spacing to fit 66 lines onto the page. This may be undesirable (such as when using pre-printed forms that must align correctly). In these cases, the ␣TY command prevents the printer from compressing the line spacing.

Use the ␣I and ␣S commands to remove unwanted host commands from a print file. For example, when printing with electronic forms software, these files are recognized by the host as text files, which causes the host to format the files with unwanted carriage returns and line feeds. Placing the ␣I at the end of a line and ␣S at the front of the next line causes the interface to remove the host carriage return and line feed commands and send only the data to the printer.

OPERATION

I-O's laser printer emulation is compatible with the many popular electronic forms software applications. If the Print Box replaces XPoint's Twinax Controller, set the interface's True LPI menu to "XPoint Controller."



HP Line Printer

The HP Line Printer protocol allows printing of dot-matrix output on a PCL-type laser printer. When selecting the HP Line Printer protocol, the Print Box emulates an IBM 5224-1 line printer. Other IBM printers cannot be emulated.

The HP Line Printer protocol automatically prints all output in COR mode. However, portrait or landscape print orientation with the requested font is also possible. In addition, the interface offers the choice between compressed (default) and true LPI (useful when printing on pre-printed forms). When driving the attached laser printer with the HP Line Printer protocol, reports can be printed at high print speeds and with superior print quality.

Matrix/Specialty Printer Operation

IBM Matrix Printer Emulations

The I-O Print Box offers the following IBM matrix printer emulations in addition to the IBM 4214 emulation which is used as the default for most of the I-O output protocols:

- IBM 5224 Model 1
- IBM 5225 Model 1
- IBM 5256 Model 3

These IBM matrix printer emulations can be selected through Host/PC download command 24 or through the setup software. The I-O Print Box allows access to all the capabilities of the emulated IBM printer. The IBM 4214 printer offers 5,10,12,15, 16.7, and 20 CPI; 3,4,6, and 8 LPI; and print qualities of draft, fast draft, or NLQ.

The IBM 5224 and 5225 printers offer 10 and 15 CPI; 6 and 8 LPI; and only a draft print quality. The IBM 5256 printer only offers 10 CPI printing.

OPERATION

These printer emulations are often used when connecting a specialty printer, such as a barcode printer to an IBM host.

The I-O Print Box offers the following output protocols for matrix and specialty printers:

- IBM PPDS
- IBM Proprinter 4201/4202
- Epson, 9 pin (FX, DFX)
- Epson, 9 pin (DFX+)
- Epson, 24 pin (LQ)
- Generic

Character Set

By default, the interface uses the CP 850 character set. You also have the option to select the CP 437 character set, which is often used in PC applications. Please be aware that CP 437 has 41 fewer characters than CP 850.

Although the I-O Print Box artificially produces these missing characters, at times the "reproduction" may not satisfy your quality requirements.

Print Quality

The I-O Print Box's IBM 4214 printer emulation offers Draft, NLQ (Near Letter Quality), or Default print quality for print quality options. If a default print quality command is sent from the host, the interface allows you to specify whether this default is Draft or NLQ. Set the desired default print quality through Host/PC download command 22 or through the setup software.

If the printer has the capability, the I-O Print Box allows you to further specify if Draft printing should be Fast Draft or Normal Draft (Host/PC download command 23). Request for Draft printing can come directly from the host or from the interface (host sends Default print quality and interface's 4214 Default Print Quality is set to Draft). If the printer only offers one draft printing mode, the setting of the Draft Printing option is ignored.

Another way to modify the print quality is to set the printer to a certain value through its front panel. By activating the Override Format Commands option of the interface through Host/PC download command 16 the printer's

OPERATION

front panel settings are "locked in" and remain valid until the Override Format Command is disabled.

Pitch Control

The interface's 4214 emulation permits the printer to print 5, 10, 12, 15, 17.1 and 20 CPI (pitch). The pitch can vary, depending on the CPI selected in the host document or the printer's front panel.

The 5224/5225 emulation only allows 10 and 15 CPI printing, and the 5256 emulation only allows 10 CPI printing, unless the CPI is overridden at the printer's front panel.

Graphics Printing

The interface will print the same Advanced Printer Functions (APF) and Business Graphics Utility (BGU) graphics as the IBM 4214, 5224, and 5225 printers using All Points Available (APA) bit image graphics. This method is for printing continuous patterns such as bar codes and logos that come from the twinax host. This is the method of graphic printing that IBM used before IPDS was developed.

Graphics are printed on IBM System/34, /36, /38 from the APF and BGU programs and programmer-defined characters using the command Load Alternate Character (LAC).

This capability is supported by 5224, 5225 printers in spacing of 10 and 15 CPI and 4214 printers in spacing of 10, 12, and 15 CPI.

The interface implements the LAC command by taking the dot pattern received from the twinax host and then printing that exact dot pattern using the printer's APA bit image graphics at high density 240 dots/inch. This permits the printer to print APF and BGU graphic output using exactly the same spacing as the IBM 4214/5224/5225 printers.

Truncate/Wrap

For normal or wide paper (14 7/8" wide) printing, select Wrap through Host/PC download command 26 or the setup software. This allows printing to extend the full width of the wide paper. The printer wraps printing beyond the margin to the next line on narrow paper when it is configured for narrow paper.

OPERATION

When using narrow paper (8 1/2" wide), the user can select Truncate. This ignores any printing beyond 8". Documents must be formatted to fit the narrow paper, since the text beyond an 8" margin will truncate (not print).

True 15 CPI

Epson 9-pin printers, IBM Proprinters, and similar printers do not have the capability to print at 15 CPI. When the host sends a 15 CPI command, the Print Box is able to produce an "artificial" 15 CPI on the printer. This is accomplished by printing 17.1 CPI and adjusting for the spacing difference. In this manner, 15 CPI fonts sent from the host can fit on preprinted forms that must align correctly.

When using the Epson 9-pin printer driver, this is done automatically. Since the Epson DFX 5000+ is able to print 15 CPI, make sure to select the Epson DFX+ driver when operating the DFX 5000+ printer.

When using the IBM Proprinter driver, the user may manually select whether 15 CPI host commands should simply be printed as 17.1 CPI, or as 17.1 CPI with space adjustments (see Host/PC download command 28). Printing the "artificial" 15 CPI through the IBM Proprinter driver significantly reduces print speed.

Generic Mode

The Generic output protocol should be used when the other output protocols of the I-O Print Box are inappropriate. This could be the case with printers such as certain barcode label printers or embossers, but also with printers from Okidata, Mannesmann-Tally, or others. Refer to the printer's user's guide to find out if the printer operates with one of the I-O Print Box's output protocols.

In Generic mode, the interface does not pass on the LPI and CPI commands from the host. Rather, it allows you to match the printer specific CPI or LPI command with the CPI or LPI command from the host (through Host/PC download commands 84-89).

For example, assume the printer protocol the printer requires is not available on the I-O Print Box. To change the printer to 10 CPI, the printer's user's manual provides the hexadecimal value of 1B 50. Use the Host/PC download command 86 to assign the value 1B 50 to the 10 CPI string (type `&%Z86,1(1B 50)`).

OPERATION

From now on, when the interface receives a request for 10 CPI from the host, it will send the value 1B 50 to the printer and thereby set it to 10 CPI.

If nothing is assigned to the CPI or LPI string, the interface will send nothing to the printer, i.e. it will ignore the CPI or LPI command from the host.

The interface stores commands for the following CPI and LPI values:

| | |
|--------|-----------------------------|
| 6 LPI | Host/PC download command 84 |
| 8 LPI | Host/PC download command 85 |
| 10 CPI | Host/PC download command 86 |
| 15 CPI | Host/PC download command 87 |

5 ADVANCED FEATURES

Command Pass-Thru™

The Command Pass-Thru feature allows access to all of the built-in features of the printer, even if these features aren't normally available through the host software. Command Pass-Thru lets you place printer-specific command sequences into the data sent to the printer. The interface recognizes these special sequences and "passes the command through" to the printer. The steps below describe how to use Command Pass-Thru.

1. Find the command for the print feature in the printer's user's guide.
2. Convert the printer command to hexadecimal (ASCII).
3. Place **&%** (or the alternate CPT start delimiter), in the document at the point where the feature is to take effect. This signals the start of the print feature.

Enter the beginning printer command, then enter **&%** or the alternate CPT end delimiter. A space may be entered between hexadecimal code pairs to make the command easier to read, but do not put spaces between the delimiter and the hexadecimal characters.

4. Move the cursor to the point in the text where the print feature ends. Enter **&%** or the alternate CPT start delimiter, followed by the ending printer command and then **&%** or the alternate CPT end delimiter again, into the document.

For example:

The command **ESC &d0D** begins underlining and **ESC &d@** ends underlining on an HP LaserJet printer. First convert the start command to the hexadecimal **1B 26 64 30 44** and the ending command to **1B 26 64 40**.

If the delimiter is the default **&%** (hex 50 6C), then enter the commands as follows:

This is an **&% 1B26643044&%underlined&% 1B266440&%** word.

to print on the printer as:

ADVANCED FEATURES

This is an underlined word.

Only characters from 01 to FF are recognized (alphabetic characters must be in upper case). Errors in the Command Pass-Thru sequence will cause the I-O Print Box to ignore the command and printing will resume at the point the error occurred.

Command Pass-Thru may invalidate horizontal spacing.

Although the command is displayed on the screen the, I-O Print Box treats it as a command and does not print it. If part of the sequence is printed, an error has been made entering the codes. Check the document and make sure the correct format and EBCDIC hexadecimal characters are being used.

Avoid sending codes that would move the print position during Command Pass-Thru. Since the I-O Print Box does not process these commands, it cannot keep track of the print position changes. This may affect the position of characters that follow the command and the page layout.

User Defined Strings

To avoid keying-in frequently used printer commands (which would appear in the document as hex values imbedded in Command Pass-Thru delimiters), you should take advantage of the User-Defined Strings feature.

Using Host/PC download command 04, assign the numbers 0 through 9 to frequently used printer command strings.

After a command string has been defined, activate it by typing the delimiter (&% or alternate CPT start delimiter) followed by the string number (U0 through U9) into the document or on the screen. When the document or screen is printed, the interface will recognize the &%U and send the command assigned to the string number to the printer.

For example, if command number U1 is assigned to a command string to turn on shadowed printing (hex codes 1B 28 73 31 32 38 53) for a Lexmark 4039 printer, then simply enter &%U1 in the document at the point where shadow printing is to begin.

ADVANCED FEATURES

Some commands (such as emphasized (bold) printing) may continue until another string is encountered that returns printing to normal, or for some host systems, until the next page is sent to the printer.

The interface self-test prints out a list of command numbers and the command strings assigned to them.

User Defined Fonts (HP PCL only)

The I-O Print Box TxP plus supports a vast variety of fonts. For a list of the supported fonts refer to Appendices A and B. In addition, the User-Defined Fonts feature allows assignment of new or existing font IDs to different printer resident fonts or fonts from an optional font cartridge. Up to 10 new pairs of font IDs and fonts can be created.

The following example assumes an HP 4Si is connected to the I-O Print Box TxP plus and the default font is specified as font 11. The font ID 11 represents the font Courier 10 CPI. If you want to change the default font but maintain the font ID 11, simply assign a new font to font ID 11 (e.g. Courier bold 10 CPI). This is done by sending the Host/PC download command `&%Z21,0,11(<(12U<(s0p10h12v0s3b4099T)` to the printer. Font ID 11 has now been redefined as Courier bold 10 CPI. Consult the printer's user's guide for the information needed to write the string.

In the same manner, personalized font IDs can be assigned to printer resident fonts or to fonts from an optional font cartridge. These fonts can then be called up by using the newly assigned font ID, the same way the standard printer resident fonts are called up.

User defined fonts cannot be used with the `↵F` font change commands.



Color Printing

The I-O Print Box allows printing of color on PCL5C - compatible printers such as the HP Color LaserJet, DeskJet 1200C, or 1600C printer. Simply insert the I-O color command in front of the text you want to colorize. Return to the "normal" black color by inserting `↵C00`. The I-O color commands are:

ADVANCED FEATURES

| | |
|-----------------------|-----------------------|
| –C00 - Black | –C09 - Dark Blue |
| –C01 - Blue | –C10 - Orange |
| –C02 - Red | –C11 - Purple |
| –C03 - Magenta | –C12 - Dark Green |
| –C04 - Green | –C13 - Dark Turquoise |
| –C05 - Turquoise/Cyan | –C14 - Mustard |
| –C06 - Yellow | –C15 - Grey |
| –C07 - White | –C16 - Brown |
| –C08 - Black | |

For example, to print the work "red" in the color red in the following sentence, type:

This prints –C02red–C00 in red.

Alternately, you can select a color through the **Typestyle/color** menu of Office Version/400 (V3R1 or later). This menu is accessed by selecting F20 (Format Options), 1 (Document Options), 1 (Document Format), and finally 3 (Typestyle/color).

You can also create one or more additional colors using the User-Defined String feature described on page 5-2.

To print a customized color, you need to follow these steps:

1. Set up a color palette.
2. Define the color.
3. Print the color.

For detailed information on this process, consult HP's PCL5 Color Technical Reference Manual. Here is a quick overview on how to define and print colors using I-O's User-Defined Command String feature.

1. To set up a color palette, send the following string to the printer (using the Host/PC download command 04).

```
&%Z04,0(1B 2A 76 36 57 00 00 08 08 08)
```

ADVANCED FEATURES

Note: The `&%Z04,0(..)` stores the actual command string (1B 2A ..) in the interface and assigns it the macro identifier U0.

2. To define and print a color send the following string to the printer:
`&%Z04,1(1B 2A 76 30 61 30 62 30 63 31 69 31 53)`.

Note: The first 30 (preceding the value 61) identifies the amount of red of the color. Values can range from 0 (hex 30) to 255 (hex 32 35 35). The second 30 (preceding the value 62) identifies the amount of green. The third 30 (preceding the value 63) identifies the amount of blue you are adding to the color. The color of your choice is created by mixing these three colors (red, blue, green). The number 31 (preceding the value 69) assigns your customized color the value 1. The second 31 (preceding the value 52) calls up this number again and prints it.

3. Once you have sorted the color command strings in the interface's memory as described above, you can switch to the defined color any time by simply inserting the commands `&%U0` (to set up the color palette) and `&%U1` (to print the color) in the data stream.

Example:

1. To define the color red and store the customized "red" command in the interface under the macro name U3 type the following:

```
&%Z04,0(1B 2A 76 36 57 00 00 08 08 08)
[This string sets up the color palette.]
&%Z04,3(1B 2A 76 32 35 35 61 30 62 30 63 31 69 31 53) [This
command defines and prints the color red. Notice that the defined
color consists of red (255) only. Green and blue components have
been given the value 0 (hex 30).]
```

2. To print the word "red" in this sentence red, type:

To print the word `&%U0 &%U3"red"¬C08` in this sentence red, type:

Note: The `¬C08` in the above example returns the print color back to black.

ADVANCED FEATURES

Printing Bar Codes

When generating bar codes on an IBM AS/400 or S/3X, the I-O interface must be attached to a PCL laser printer with PJL support and emulate an IBM 3812-1 printer, or to a dot-matrix printer operating in either Epson or IBM Proprinter or PPDS mode and emulate an IBM 4214 or 5224/25/56 printer.

The following applies to printing bar codes on laser printers as well as on dot matrix printers, unless specified otherwise.

Using the I-O bar code feature, the following bar codes can be easily printed:

| Type | Bar Code |
|------|--------------------|
| 1 | Code 3 of 9 |
| 2 | Code 128 |
| 3 | Interleaved 2 of 5 |
| 4 | POSTNET |
| 5 | UPC A |
| 6 | EAN 8 |
| 7 | EAN 13 |

To print any of these bar codes, use the following format:

¬B<type>,<height>,<width>,<hr>,<chkd>,<ast>,<data>¬B

The bar code command string must contain all of these parameters, even if the parameter is irrelevant for the type of bar code being printed. For example, POSTNET comes in only one size, therefore, any height or width specifications are ignored.

¬B Identifies the strings as a bar code command string. ¬B must be placed at the beginning and at the end of the string.

<type> Specifies the bar code type according to the table shown above.

<height> Specifies the height of the bar code. Height is expressed in multiples of 2.5 mm (approximately 1/10 inch).

ADVANCED FEATURES

The height of the bar code can range from 1 (2.5 mm) to 9 (22.5 mm) inclusive.

Height values are ignored if a POSTNET bar code is being printed, since POSTNET uses one standard height. However, a valid value (1-9) must be entered for the height parameter to ensure the bar code command string is complete.

<width> Specifies the width of a bar code module. A module is defined as a specific combination of bars and spaces used to represent a human readable character.

By changing the width parameter, you can determine the width of the module and the thickness of the bars and spaces.

Width parameters can range from 1 to 9.

To determine the total length of the bar code, simply multiply the module length (found in the table on the following page) with the number of bar code characters.

Note: Be aware that the table gives rounded values only.

Example: Using Code 3 of 9, you want to bar code the word "PRINTERS." Assume the interface also generates a check digit and the start/stop characters. Setting the width parameter to 2 will yield a total bar code length of approximately 4 cm or about 1½ inches.

Number of characters: 11 (8 letters (PRINTERS) + 2 start/stop characters + 1 check digit)

Module width (from table below:) 3.6 mm (.14 inches)

Calculation: $11 \times 3.6 \text{ mm} = 39.6 \text{ mm} = 3.96 \text{ cm}$; or $11 \times .14 \text{ in} = 1.54 \text{ inches}$

ADVANCED FEATURES

Module Width in mm (inches) - PCL Laser

| Width | 1 | 2 | 3 | 4 | 5 | 6 | 7 | 8 | 9 |
|-----------------------|--------------|--------------|--------------|--------------|--------------|--------------|--------------|--------------|---------------|
| Code 3 of 9 | 2.6 (.1) | 3.6 (.14) | 4.5 (.18) | 5.5 (.22) | 6.5 (.25) | 7.5 (.29) | 8.4 (.33) | 9.4 (.37) | 10.4 (.41) |
| Code 128 | 2.2 (.09) | 3.1 (.12) | 3.9 (.15) | 4.7 (.19) | 5.6 (.22) | 6.4 (.25) | 7.3 (.29) | 8.1 (.32) | 8.9 (.35) |
| Interleaved 2 of 5 | 2.3 (.09) | 3.2 (.12) | 4 (.16) | 4.9 (.19) | 5.8 (.23) | 6.6 (.26) | 7.5 (.3) | 8.4 (.33) | 9.3 (.36) |
| Postnet | 5.7 (.23) | | | | | | | | |
| EAN-13 | 1.5 (.06) | 2 (.08) | 2.5 (.1) | 3.1 (.12) | 3.6 (.14) | 4.2 (.16) | 4.7 (.18) | 5.2 (.20) | 5.8 (.23) |
| EAN-8 | 1.7 (.07) | 2.3 (.09) | 2.9 (.11) | 3.6 (.14) | 4.2 (.16) | 4.8 (.19) | 5.4 (.21) | 6.1 (.24) | 6.7 (.26) |
| UPC A | 1.6 (.06) | 2.2 (.08) | 2.8 (.11) | 3.4 (.13) | 4 (.16) | 4.6 (.18) | 5.2 (.2) | 5.8 (.23) | 6.4 (.25) |

Module width in mm (inches) - Epson or IBM Dot-Matrix

| Width | 1 | 2 | 3 |
|--------------------|--------------|--------------|--------------|
| Code 3 of 9 | 2.7 (.11) | 5.4 (.22) | 8.1 (.32) |
| Code 128 | 2.5 (.1) | 5 (.2) | 7.6 (.3) |
| Interleaved 2 of 5 | 2.2 (.9) | 4.4 (.18) | 6.6 (.26) |
| POSTNET | 6.5 (.25) | | |
| EAN 13 | 1.5 (.06) | 3.1 (.12) | 4.6 (.18) |
| EAN 8 | 1.8 (.07) | 3.6 (.14) | 5.5 (.21) |
| UPC A | 1.8 (.07) | 3.6 (.14) | 5.5 (.21) |

ADVANCED FEATURES

Width parameters are ignored when printing POSTNET bar codes, since POSTNET uses one standard width. However, a valid value (1-9) must be entered for the width parameter to ensure the bar code command string is complete.

<hr> Identifies whether human readables are printed or not. Human readables are printed underneath the bar code. Valid values are:

- 0 = Do not print human readables.
- 1 = Print human readables.

<chkd> Indicates whether the I-O interface automatically calculates and causes a check digit to be printed. The following bar codes **require** a check digit, therefore, the interface automatically generates and adds a check digit to the bar code data: Code 128, POSTNET, UPC A, EAN 8, EAN 13

If any of the bar codes listed above has been selected, the <chkd> selection is ignored by the interface. However, one of the following values must be entered to ensure the bar code command string is complete and valid. The options for the <chkd> parameter are:

- 0 = Do not calculate and add a check digit.
- 1 = Calculate and add a check digit to the bar code data.

<ast> Specifies whether start/stop characters are automatically generated or manually added. **This parameter only applies to bar code type Code 3 of 9.** For all other bar code types, the start/stop characters are automatically generated by the interface and input for the <ast> parameter is ignored. However, one of the following values must be entered to ensure the bar code command string is complete and valid. The options for the <ast> parameter are:

- 0 = Do not automatically add start/stop characters.
- 1 = Automatically add start/stop characters.

Note: If value 0 is selected, you **must** manually enter start/stop characters (asterisks) together with the data. Failure to add the asterisks will cause an invalid bar code to be printed (i.e. a bar

ADVANCED FEATURES

code without start/stop characters). If human readables are being printed, the asterisks will also print as human readables.

If value 1 is selected, you **must not** add asterisks as start/stop characters to the data. Failure to omit asterisks will cause an invalid bar code to be printed (i.e. a bar code with a start/stop character pair in the beginning and a start/stop character pair in the end.)

<data> The data to be printed as a bar code. Some bar codes require a certain number of characters. Others only allow alphanumeric or numeric characters. Before the I-O interface processes the data string, it will check the complete data string and verify that it is valid. This is why the `␣B` at the end is so important. If an invalid data string has been entered, the interface will print "Invalid Data" in the place of the bar code.

Notes:

1. Valid values must be entered for each of the parameters specified above, even if the parameter is irrelevant for the type of bar code being printed.
2. If an invalid parameter value (other than invalid data) has been entered, the interface will process the bar code command up to that point and then reject any information it receives after the incorrect value.

For example, a bar code command string has been entered, however, an invalid `<hr>` value of 3 has been specified.

```
␣B2,6,6,3,0,0,code128␣B
```

The interface would cause all characters after the invalid value 3 to be printed:

```
,0,0,code128
```

This helps quickly identify where the mistake occurred.

3. Spaces in the bar code command string are invalid and will lead to the same result as mentioned in Step 2.

ADVANCED FEATURES

4. If invalid data (either too many characters or the wrong type of characters) is entered, the interface will print the error message:
** Invalid Data **
5. Allow for sufficient vertical spacing when printing text data beneath the bar code.

For example, when the bar code command sting is entered on line 1 of the document with a bar code height specified as 5 (approximately 1/2 inch or 3 lines at 6 LPI), and text is then entered on line 2 as follows,

```
-B5,7,1,0,0,0,1234567890-B  
This data overrun by barcode
```

this will cause the bar code to overlap the text in the second line:

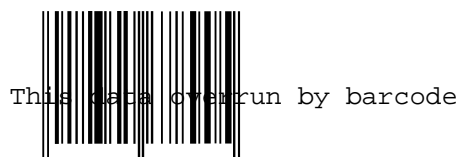

To avoid overlapping bar codes with text, always allow for sufficient vertical line spacing (e.g. line feeds) to accommodate the height of the bar code.

6. When text data is entered to the right of the bar code command sting, the printed text will appear immediately to the right of where the bar code print ends.

Overview and Examples

The following examples give an overview of the supported bar code types. Note that the "maximum number of data characters" does not include start/stop characters and check digits.

ADVANCED FEATURES

Code 3 of 9

Maximum number of data characters: 30
Valid numeric characters: 0-9
Valid alphanumeric characters: A-Z
Valid other characters: space \$ % + - . / *

Example:

␣B1,4,1,1,1,1,0123456789␣B



0123456789

POSTNET

Maximum number of data characters: 30
Valid numeric characters: 0-9
Valid alphanumeric characters: N/A
Valid other characters: N/A

Example:

␣B4,1,1,1,1,0,0123456789␣B



0123456789

UPC A

Required number of data characters: 10
Valid numeric characters: 0-9
Valid alphanumeric characters: N/A
Valid other characters: N/A

Example: ␣B5,5,1,1,1,0,0123456789␣B



0|01234|56789|5

ADVANCED FEATURES

EAN 8

| | |
|-------------------------------------|-----|
| Required number of data characters: | 7 |
| Valid numeric characters: | 0-9 |
| Valid alphanumeric characters: | N/A |
| Valid other characters: | N/A |

Example: -B6,3,1,1,1,0,1234567-B



EAN 13

| | |
|-------------------------------------|-----|
| Required number of data characters: | 12 |
| Valid numeric characters: | 0-9 |
| Valid alphanumeric characters: | N/A |
| Valid other characters: | N/A |

Example: -B7,3,1,1,1,0,012345678912-B



Interleaved 2 of 5

| | |
|------------------------------------|-----|
| Maximum number of data characters: | 30 |
| Valid numeric characters: | 0-9 |
| Valid alphanumeric characters: | N/A |
| Valid other characters: | N/A |

Example:
-B3,3,1,1,1,0,0123456789-B



ADVANCED FEATURES

Note: Since Interleaved 2 of 5 symbols are created from data character pairs, the number to be encoded must have an even number of digits. If an odd number of data characters (including the optional check digit) is entered, the interface adds an "0" to the beginning of the bar code. If an even number of data characters (including the optional check digit) is entered, the interface prints the bar code exactly as it is input.

Code 128

Code 128 has three unique character subsets (code A, B, and C) shown in the table on the following pages. When entering data representing Code 128 bar code, follow these two steps:

1. Define which code set you want to use. For example, type "A" to represent code A; type "B" to represent Code B; and type "C" to represent code C.
2. If you are using code set B, enter the data characters directly. The ~ character and other special characters are represented by the Symbol Character Value found in the left column of the table on the following pages.

If you are using code set A or C, enter the Symbol Character Value found in the left column of the table. Each character is represented by two digits or a ~ followed by a digit. For example, to bar code the character "&" using Code Set A, type 06.

Maximum number of data characters: 30 (includes special characters) Valid characters: Differs with selected code set, see table on following pages

Example: ~B2,3,2,1,1,0,BABCDEFGHIJKLMN0PQRSTUVWXYZ~B



ADVANCED FEATURES

To show how multiple character sets are used, study the following data string. Height, width and other parameters were omitted in this example to focus your attention on the data string. Please note that this example is for illustration purposes only, and is not a recommended way of bar coding. The following data string is a fairly complex way of bar coding
10PrintBoxes10 .

~B2,....,A1716~6PrintBoxes~510~B

A: selects code set A
 17: selects the number 1 from code set A
 16: selects the number 0 from code set A
 ~6: switches from code set A to code set B
 PrintBoxes: selects the characters PrintBoxes from code set B
 ~5: switches from code set B to code set C
 10: selects the number 10 from code set C

| Symbol Character Value | Data Character | | |
|------------------------------|----------------|--------|--------|
| | Code A | Code B | Code C |
| 00 | SP | SP | 00 |
| 01 | ! | ! | 01 |
| 02 | " | " | 02 |
| 03 | # | # | 03 |
| 04 | \$ | \$ | 04 |
| 05 | % | % | 05 |
| 06 | & | & | 06 |
| 07 | ' | ' | 07 |
| 08 | (| (| 08 |
| 09 |) |) | 09 |
| 10 | * | * | 10 |
| 11 | + | + | 11 |
| 12 | , | , | 12 |
| 13 | - | - | 13 |
| 14 | . | . | 14 |
| 15 | / | / | 15 |
| 16 | 0 | 0 | 16 |
| 17 | 1 | 1 | 17 |
| 18 | 2 | 2 | 18 |
| 19 | 3 | 3 | 19 |

ADVANCED FEATURES

| Symbol Character Value | Data Character Code A | Code B | Code C |
|---------------------------------------|----------------------------------|---------------|---------------|
| 20 | 4 | 4 | 20 |
| 21 | 5 | 5 | 21 |
| 22 | 6 | 6 | 22 |
| 23 | 7 | 7 | 23 |
| 24 | 8 | 8 | 24 |
| 25 | 9 | 9 | 25 |
| 26 | : | : | 26 |
| 27 | ; | ; | 27 |
| 28 | < | < | 28 |
| 29 | = | = | 29 |
| 30 | > | > | 30 |
| 31 | ? | ? | 31 |
| 32 | @ | @ | 32 |
| 33 | A | A | 33 |
| 34 | B | B | 34 |
| 35 | C | C | 35 |
| 36 | D | D | 36 |
| 37 | E | E | 37 |
| 38 | F | F | 38 |
| 39 | G | G | 39 |
| 40 | H | H | 40 |
| 41 | I | I | 41 |
| 42 | J | J | 42 |
| 43 | K | K | 43 |
| 44 | L | L | 44 |
| 45 | M | M | 45 |
| 46 | N | N | 46 |
| 47 | O | O | 47 |
| 48 | P | P | 48 |
| 49 | Q | Q | 49 |
| 50 | R | R | 50 |
| 51 | S | S | 51 |
| 52 | T | T | 52 |
| 53 | U | U | 53 |
| 54 | V | V | 54 |
| 55 | W | W | 55 |
| 56 | X | X | 56 |
| 57 | Y | Y | 57 |

ADVANCED FEATURES

| Symbol Character Value | Data Character Code A | Code B | Code C |
|------------------------------|--------------------------|--------|--------|
| 58 | Z | Z | 58 |
| 59 | [| [| 59 |
| 60 | \ | \ | 60 |
| 61 |] |] | 61 |
| 62 | ^ | ^ | 62 |
| 63 | _ | _ | 63 |
| 64 | NUL | ` | 64 |
| 65 | SOH | a | 65 |
| 66 | STX | b | 66 |
| 67 | ETX | c | 67 |
| 68 | EOT | d | 8 |
| 69 | ENQ | e | 69 |
| 70 | ACK | f | 70 |
| 71 | BEL | g | 71 |
| 72 | BS | h | 72 |
| 73 | HT | i | 73 |
| 74 | LF | j | 74 |
| 75 | VT | k | 75 |
| 76 | FF | l | 76 |
| 77 | CR | m | 77 |
| 78 | So | n | 78 |
| 79 | S | o | 79 |
| 80 | DLE | p | 80 |
| 81 | DC1 | q | 81 |
| 82 | DC2 | r | 82 |
| 83 | DC3 | s | 83 |
| 84 | DC4 | t | 84 |
| 85 | NAK | u | 85 |
| 86 | SYN | v | 86 |
| 87 | ETB | w | 87 |
| 88 | CAN | x | 88 |
| 89 | EM | y | 89 |
| 90 | SUB | z | 90 |
| 91 | ESC | { | 91 |
| 92 | FS | | 92 |
| 93 | GS | } | 93 |
| ~0 | RS | ~ | 94 |
| ~1 | US | DEL | 95 |

ADVANCED FEATURES

| Symbol Character Value | Code A | Data Character Code B | Code C |
|------------------------------|--------|--------------------------|--------|
| ~2 | FNC3 | FNC3 | 96 |
| ~3 | FNC2 | FNC2 | 97 |
| ~4 | SHIFT | SHIFT | 98 |
| ~5 | CODE C | CODE C | 99 |
| ~6 | CODE B | FNC4 | CODE B |
| ~7 | FNC4 | CODE A | CODE A |
| ~8 | FNC1 | FNC1 | FNC1 |

plus I-O Graphics Language™

The I-O Graphics Language™ (IOGL™) allows printing of graphical elements and charts on PCL5 compatible printers from the IBM host. IOGL is independent of other I-O features, such as internally generated bar codes or font change commands. This means that if an I-O font change command is followed by a IOGL command to rotate text, the text would print in the specified font. IOGL is also independent of regular text data. This allows text data to be overlaid by a graphical element, such as a shaded box.

ADVANCED FEATURES

I-O Graphics Language™ Overview

The following table is an overview of the I-O Graphics Language™ (IOGL) command strings and a brief description of the parameters used in the IOGL strings.

| Graphical Element | IOGL Command String |
|-----------------------|--|
| Line | -GL<line width>;<x start>;<y start>;<x end>;<y end> |
| Box | -GB<line width>;<x start>;<y start>;<x end>;<y end>;<% shading> |
| Circles | -GC<line width>;<x center>;<y center>;<radius>;<% shading> |
| Arc | -GA<line width>;<x start>;<y start>;<x center>;<y center>;<angle of rotation> |
| Shading/Color | -GS<# of values>;<color 1>;<% shading 1>;<color 2>;<% shading 2>;. . . |
| Pie Chart | -GP<line width>;<x center>;<y center>;<radius>;<# of segments>;<segment value 1>;<segment value 2>;. . . |
| Bar Chart (Histogram) | -GH<line width>;<x start>;<y start>;<x increment>;<y increment>;<bar width>;<# of entries>;<value 1>;<value 2>;. . . |
| Run (Line) Chart | -GR<line width>;<x start>;<y start>;<x increment>;<y increment>;<# of entries>;<value 1>;<value 2>;. . . |
| Text Rotation | -GT<x start>;<y start>;<angle of rotation>;<'text'> |
| Comments | -GX<'text'> |

ADVANCED FEATURES

| Parameter | Description | Units of Measurement | Valid Values |
|-------------------|---|---------------------------|---|
| 'text' | text to be rotated or to be included in the IOGL program as a comment | N/A | any printable character |
| % shading | percentage of shading | percentage | 0-100, integers |
| # of segments | number of segments to be printed in pie chart | each | 1 to 9, integers |
| # of entries | number of values to be printed in bar or run (line) chart | each | 1 to 12, integers |
| angle of rotation | angle of rotation of arc or text | degrees | arc: 0 to 360, integers text: 0, 90, 180, 270 |
| bar width | width of a bar in a bar chart | n/300 inch | positive integers |
| color n | I-O color code to select color of pie or bar chart segments | I-O color command numbers | 00 to 16 |
| line width | width of any printed line (in line, box, arc, circle, chart) | mm | any positive number |
| radius | radius of a circle or pie chart | n/300 inch | positive integers |
| segment value n | value to be represented by a pie chart segment | integer | 0 to 100 |

ADVANCED FEATURES

| Parameter | Description | Units of Measurement | Valid Values |
|------------------|---|-----------------------------|----------------------------|
| value n | a value to be represented by a bar in a bar chart or a point in a line chart | any positive integer | any positive integer |
| x start | x coordinate of start position for lines and boxes | n/300 inch | positive integers; incl. 0 |
| x end | x coordinate of end position for lines and boxes | n/300 inch | positive integers; incl. 0 |
| x center | x coordinate of center point of circle, arc, or pie chart | n/300 inch | positive integers; incl. 0 |
| x increment | horizontal movement before next bar (bar chart) or value (run chart) is printed | n/300 inch | positive integers; incl. 0 |
| y center | y coordinate of center point of circle, arc, or pie chart | n/300 inch | positive integers; incl. 0 |
| y start | y coordinate of start position for lines and boxes | n/300 inch | positive integers; incl. 0 |
| y end | y coordinate of end position for lines and boxes | n/300 inch | positive integers; incl. 0 |
| y increment | height of one unit of the value to be printed in bar or run (line) chart | n/300 inch | positive integers; incl. 0 |

ADVANCED FEATURES

Helpful Hints

1. All xy values (start, end, center, increment) are measured in n/300 of an inch. The origin of the xy coordinate system is the top left hand corner of the printable area of the page (see Figure 1).

The printable area of the page may vary with the printer model and paper size being used. Refer to your printer's user's guide for specific information.

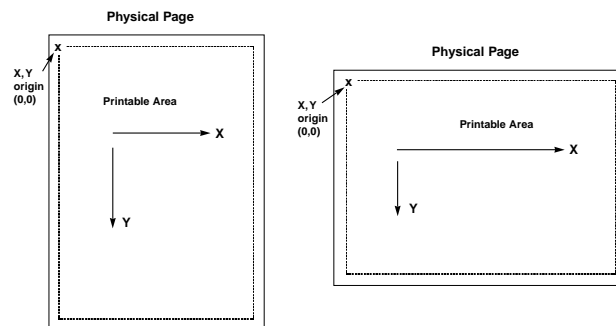

Figure 1

2. The complete command string must be entered as shown below. Incomplete command strings and command strings with invalid values (such as spaces) will cause the interface to print the string at the place the error occurred.

For example, a line command string has been entered. However, an invalid <x start> value has been specified.

```
-GL30;A;1;1;600
```

The interface would cause all characters, including the invalid value "A" to be printed:

```
A;1;1;600
```

3. As an alternative to using the semi-colon ";" as a separator between parameters, you may also enter a comma "," or a forward slash "/".

ADVANCED FEATURES

4. Do not enter numeric values with commas (i.e. 50,000). The printer interface will interpret the " ," to be the end of the parameter (i.e. 50,000 would be interpreted as two values: value 1 = 50, value 2 = 000).

International users should also be aware that a decimal value used to specify line width (in mm) such as "1,5" (i.e. 1 1/2) is also interpreted as two separate values (i.e. value 1 = 1, value 2 = 5). To enter a valid decimal line width use the period "." (i.e. 1.5 mm).

Basic Description

Lines -`-GL<line width>;<x start>;<y start>;<x end>;<y end>`

Draws a line from the specified xy start to xy end. <Line width> is specified in mm.

For example: `-GL2;100;0;100;600` draws a 2 mm wide, vertical (<x start> = <x end>) line of 2 inches in length (<y-end> - <y-start> = 600/300" = 2") (Figure 2)

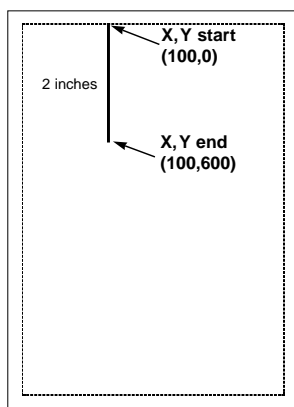

Figure 2

ADVANCED FEATURES

Boxes - `-GB<line width>;<x start>;<y start>;<x end>;<y end>;<% shading>`

Draws a box from the specified xy start to the xy end. The box cannot be rotated.<line width> is specified in mm, <% shading> can range from 0 to 100.

For example: `-GB2;300;300;600;600;30` draws a box with 2 mm wide border and 30% shading (Figure 3)

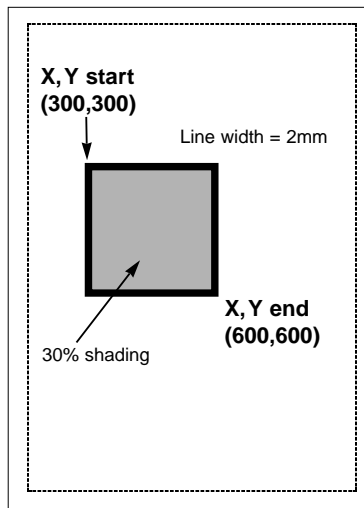

Figure 3

ADVANCED FEATURES

Circle - `-GC<line width>;<x center>;<y center>;<radius>;<% shading>`

Draws a circle with the specified radius (in n/300 inches) and line width (in mm) around the xy center.

For example: `-GC2;900;2400;300;70` draws a circle with a radius of 1 inch (300/300 inches) (Figure 4)

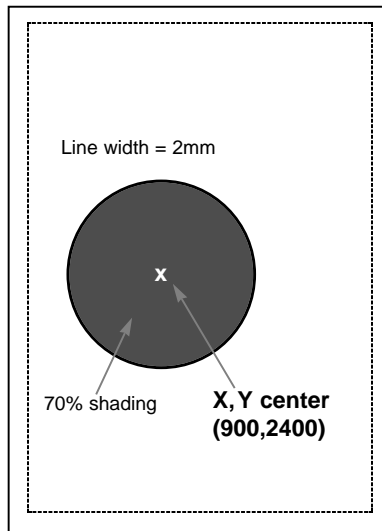

Figure 4

Note: To avoid cutting off part of the circle, make sure that the radius and the x,y center values are such that the complete circle will fit into the printable area of the page.

ADVANCED FEATURES

Arc - `-GA<line width>;<x start>;<y start>;<x center>;<y center>;<angle of rotation>`

Draws an arc around the xy center, starting at xy start and ending when the angle of rotation is completed. (Angle is measured from theoretical line xy center to xy start and rotates clockwise.)

For example: `-GA1;500;900;900;900;180` draws an arc (semi-circle since rotation is 180 degrees) (Figure 5)

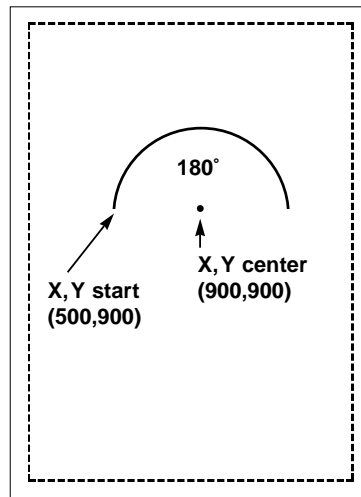

Figure 5

ADVANCED FEATURES

Color/Shading - `-GS<# of values>;<color 1>;<% shading 1>;<color 2>;<% shading 2>; . . .`

Defines the color and shading of the pie chart and bar chart segments. The first value entered in the pie and bar chart commands will be printed in color 1 with shading 1. The second value entered in the pie and bar chart commands will be printed in color 2 with shading 2.

Colors are entered as numeric values 0-16 (corresponding to I-O color command scheme). Shading is entered as a numeric value from 0-100 (% of shading). If the attached printer is not capable of recognizing PCL color commands, all printing will be black. Refer to pie and bar charts for an example.

Pie Chart - `-GP<line width>; <x center>;<y center>;<radius>;<# of segments>;<segment value 1>;<segment value 2>;....`

Draws a pie chart around the xy center with the specified radius (in n/300 inches), number of segments (maximum of 9), and segment values. Segment values are entered as numeric and converted to percentages. Segment values can range from 0 to 100.

Each segment will have the color and/or shading as specified in the shading command (pie chart value 1 will get color/shading value 1,...). `<line width>` is specified in mm. The first pie segment starts at "9 o'clock", meaning on the far left of the circle (Figure 6a).

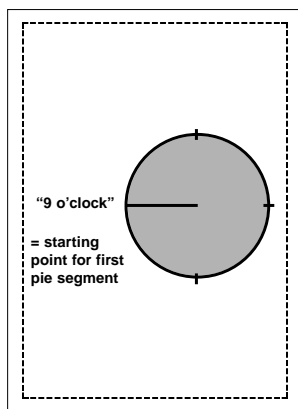

Figure 6a

ADVANCED FEATURES

For example: `GS3;01;20;02;50;04;80 GP5;900;2400;600;3;10;20;30` draws a three-segment pie chart. If the attached printer is a PCL color printer, the first segment will be blue (01), the second segment will be red (02), and the third segment will be green (04). The segments will be shaded at 20%, 50%, and 80% respectively.

The first segment (value 10) will be 1/6 of the complete circle ($10/(10+20+30)=10/60=1/6$), the second segment (value 20) will be 2/6 of the complete circle ($20/60$), and the third segment will be 3/6 of the complete circle (Figure 6b).

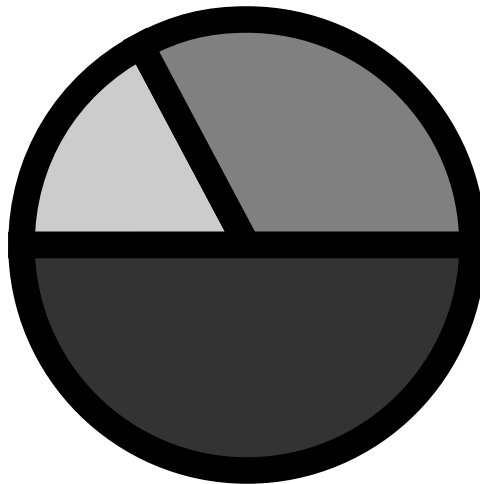

Figure 6b

Bar Chart (Histogram) - `GH<line width>;<x start>;<y start>;<x increment>;<y increment>;<bar width>;<# of entries>; <value 1>;<value 2>; ...`

Draws a bar chart. `xy start` specifies the bottom left hand corner of the first bar (the origin on the chart's `xy`-scale). The `x increment` specifies the horizontal movement before the next bar is printed. The `y increment` (in `n/300` inches) determines the height of the bar (multiplied by the value). The `bar width` (in `n/300` inches) specifies the width of the bar. Bar chart values can range from 0 to 3,000. Each bar will have the color and/or shading as specified in the shading command (bar 1 is color/shading value 1,...). A maximum of 12 bars can be printed.

ADVANCED FEATURES

For example: `-GS3;01;20;02;50;04;80`
`-GH1;100;2400;300;1;100;3;500;600;800` draws three bars. If the attached printer is a PCL color printer, the first bar will be blue, the second red, and the third green. The bars will be shaded 20%, 50%, and 80% respectively (Figure 7).

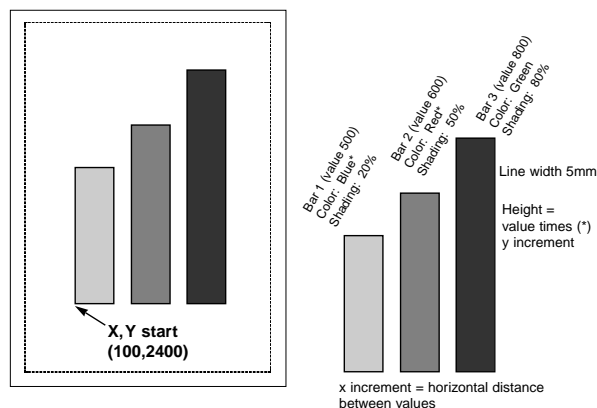

Figure 7

Each bar is 1/3 inch wide (100/300 inch). The distance from the left side of one bar to the left side of the next bar is one inch (300/300). This allows other bars to be added through a separate command.

Bar 1 will be 1 2/3 inches (500 x 1/300 inch) high, bar 2 will be two inches high (600 x 1/300 inch), and bar 3 will be 2 2/3 inches high (800 x 1/300 inch).

Note: The y-increment determines the scaling. Only integers (i.e. 1, 2, 3, 4, etc.) are valid. If you are charting sales figures in thousands of dollars, the y-increment should be small (for example, 1). If you are charting the number of customer complaints per period the y-increment should be high (for example, 100 or more). Be aware that the bar height must not exceed the total printable area of the page.

ADVANCED FEATURES

Run Chart - `-GR<line width>;<x start>;<y start>;<x increment>;<y increment>;<# of entries>;<value 1>;<value 2>; ...`

Draws a run (line) chart. The xy start specifies the origin of the chart's xy scale (xy axes are not drawn). The x increment specifies the horizontal movement before the next value is printed. The y increment determines the height of the line (multiplied by the value).

For example: `-GR3;900;2400;150;1;5;100;300;200;500;400` draws a run (line) chart (Figure 8).

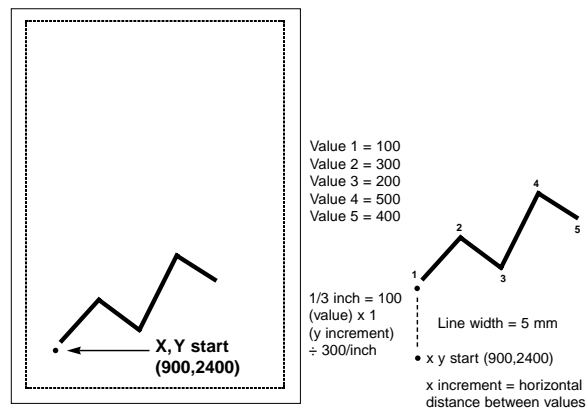

Figure 8

Note: The y-increment determines the scaling. Only integers (i.e. 1, 2, 3, 4, etc.) are valid. If you are charting sales figures in thousands of dollars, the y-increment should be small (for example, 1). If you are charting the number of customer complaints per period the y-increment should be high (for example, 100 or more).

Text - `-GT<x start>;<y start>;<angle of rotation>;<'text'>`

Prints the text ('text') in the active font, with the specified rotation and specified xy start. Text will be rotated counter clockwise.

ADVANCED FEATURES

For example: `-GT1000;1000;90;'TEXT'` prints the word "TEXT" in the active font with 90 degree rotation (Figure 9).

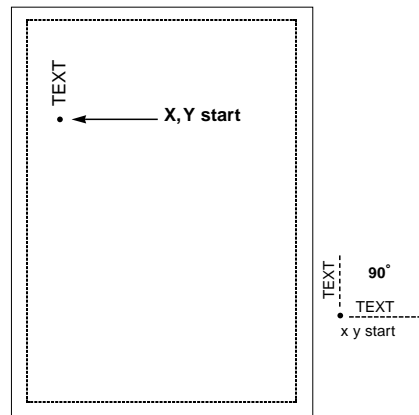

Figure 9

Comments - `-GX<'text'>`

Allows text to be added to IOGL commands for documentation. Comments will not print out.

For example: `-GX'Pie chart with 3 elements'` can be used to document an IOGL pie chart command.

ADVANCED FEATURES

I-O Graphic Language™ (IOGL) in Action

General Steps

I-O Graphics Language™ (IOGL) can be used in many different ways. It can enhance the appearance of standard host reports through a few simple graphical elements such as lines, boxes, and circles; or it can be used to present pertinent data through charts. IOGL can even be used to create sophisticated electronic forms. However, to utilize IOGL all applications have the following in common:

1. Determine which IOGL elements are needed to create the desired output (i.e. the bar chart shown below uses four different IOGL elements).
2. Determine the printable area of the page.
3. Determine the positioning of the graphical elements relative to the top left hand corner of the printable area.
4. **PCL color printer only.** Determine the order in which to print the graphical elements. The lines of the last IOGL element will overlap (and cover) the previous IOGL elements.
5. Design the graphical output, one element at a time.
6. Link the graphical output with your host application.

Tutorial

The following example (Figure 10) shows how multiple IOGL elements interact to create a bar chart.

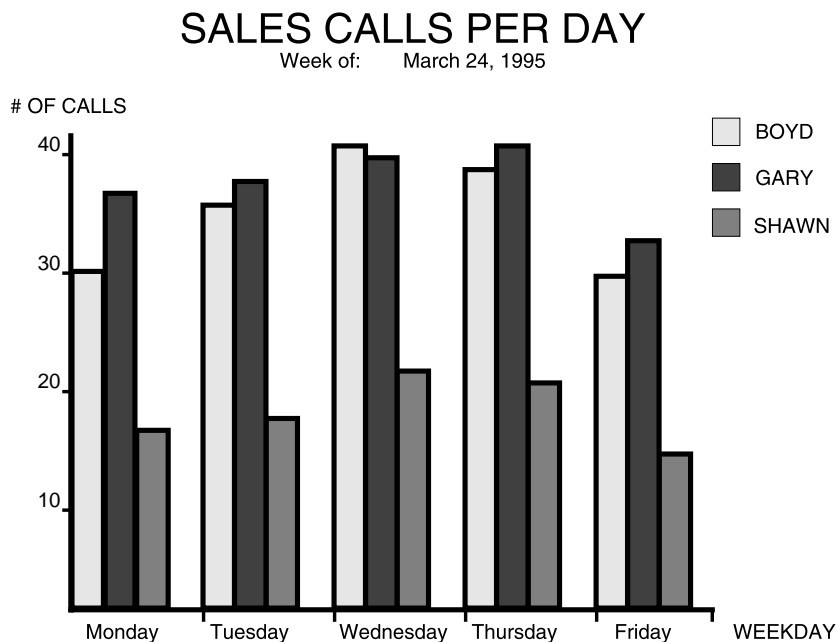

Figure 10

1. Following the above-mentioned general steps, we first determined the makeup of this bar chart. The example consists of four IOGL elements: bar charts, lines, boxes, and text.
2. To determine the printable area of the paper, we printed a box using 0;0 as the x;y -start coordinates. This was done by typing `-GB1;0;0;300;300;50` on the screen and sending it to the printer. The top left corner of the printed box marks the top left corner of the printable area of the page. For reference, we drew the printable area on the blank sheet of paper. All references to distances are made in respect to the printable page, not the actual physical page. Refer to Figure 1 on page 5-22.

ADVANCED FEATURES

- Determine where the chart should be placed (always in relation to the top left hand corner of the printable area). In the example, the bar chart is on the bottom half of a letter size page. The origin of the chart is one inch away from the left margin and 10 inches away from the top margin (Figure 11).

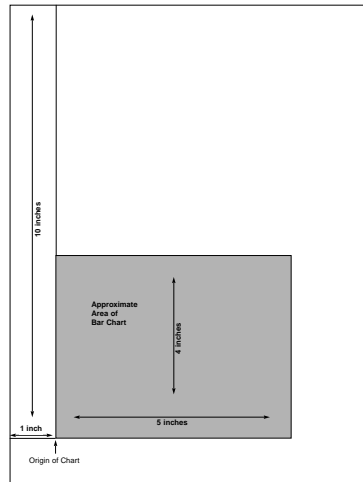

Figure 11

Next, determine the approximate maximum height and width of the chart. In the example, 40 was the expected maximum number of calls. We chose to represent 10 calls by one inch, resulting in a total maximum height of four inches (not including the title and subtitle.) Similarly, each day was represented by one inch, resulting in a total maximum width of five inches (not including the space needed for the label "WEEKDAY").

- If the chart is being printed on a black and white PCL printer, the order in which these elements are created is irrelevant. However, if you are printing on a PCL color printer, the lines of the last element will always overlay (and cover) the element previously printed. In the example, the elements creating the x and y-axes should be entered last when printing on a PCL color printer.
- Create the separate IOGL elements based on the order determined in Step 4. In the example, the bar charts were created first. Recall the IOGL formula for the bar chart and the preceding shading/color command string:

ADVANCED FEATURES

-GS<# of values>;<color 1>;<% shading 1>;<color 2>;<% shading 2>;...

-GH<line width>;<x start>;<y start>;<x increment>;<y increment>;<bar width>;<# of entries>;<value 1>;<value 2>; ...

The bar chart shown on page 5-33 was created using the following parameters:

Bar Chart Boyd

Shading/Color: Boyd's calls were plotted for each day of the business week, so the number of values is five. Since we printed to a black and white laser printer, the color parameters were irrelevant. The shading was set to 10%.

Bar Chart (Histogram): The **line width** was set to 1 mm. The **x;y-start** parameters defined the bottom left corner of the bar which is identical with the origin of the chart. Remember that the origin was one inch from the left margin, and 10 inches from the top margin of the printable area. The resulting values were 300 (=1 inch x 300/inch) for <x start> and 3000 (= 10 inches x 300/inch) for <y start.>.

The bar representing Boyd's calls for Tuesday was to be printed one inch to the right of Monday's bar. The resulting <**x increment**> was 300 (= 1 inch x 300/inch). Since the maximum height of a bar was specified at four inches, the resulting value for <**y increment**> was 30 (= 4 inches/40 max. calls x 300/inch).

To aid in readability, extra space was left between the last bar of day one and the first bar of the next day. To determine the <**bar width**> divide the available one inch (<x increment>) into four equal sections (three bars and one space). The resulting value was 75 (= 300/4). Next, count the <**# of entries**> (5) and enter the respective values. The parameters are:

-GX'bar chart Boyd'
-GS5;01;10;01;10;01;10;01;10;01;10
-GH1;300;3000;300;30;75;5;30;34;39;37;28

ADVANCED FEATURES

Bar Chart Gary

The bars representing Gary's calls were to be printed directly to the right of Boyd's. The resulting horizontal start value <x start> was:

300 (Boyd's)
+ 75 (Bar width)
375

With the exception of the actual calls, the other parameters for Gary's bar chart were identical to Boyd's. The parameters are:

```
-GX'bar chart Gary'  
-GS5;02;75;02;75;02;75;02;75;02;75  
-GH1;375;3000;300;30;75;5;35;36;38;39;31
```

Bar Chart Shawn

Shawn's bar chart was to be printed directly to the right of Gary's. The resulting horizontal starting position <x start> was:

375 (Gary's)
+ 75 (Bar width)
450

The parameters are:

```
-GX'bar chart Shawn'  
-GS5;04;50;04;50;04;50;04;50;04;50  
-GH1;450;3000;300;30;75;5;15;16;21;20;13
```

ADVANCED FEATURES

X and Y-Axes

The x-axis (Weekday) and the y-axis (# of calls), along with the increments, were created through a series of separate lines. Notice that the line width of the axis is the same as the line width of the bars. The parameters are shown below:

-GX'X-Axis with increments'

-GL1;300;3000;1850;3000

-GL.5;600;3000;600;3019

-GL.5;900;3000;900;3019

-GL.5;1200;3000;1200;3019

-GL.5;1500;3000;1500;3019

-GL.5;1800;3000;1800;3019

-GC'Y-Axis with increments'

-GL1;300;3000;300;1750

-GL.5;281;2700;300;2700

-GL.5;281;2400;300;2400

-GL.5;281;2100;300;2100

-GL.5;281;1800;300;1800

ADVANCED FEATURES

Labels/Title/Subtitle/Legend

All text was created through text rotation command strings. Text was always printed in the selected font. In the example, Universe Medium was used in different point sizes (→Q...). The legend consists of three separate boxes followed by text rotation commands. The parameters are shown below:

```
→GX'Font Change Command' →Q4808
→GX'Labels X-Axis'
→GT300;3100;0;'Monday'
→GT600;3100;0;'Tuesday'
→GT900;3100;0;'Wednesday'
→GT1200;3100;0;'Thursday'
→GT1500;3100;0;'Friday'
→GT1800;3100;0;'WEEKDAY'

→GX'Labels Y-Axis' →GT200;2700;0;'10'
→GT200;2400;0;'20'
→GT200;2100;0;'30'
→GT200;1800;0;'40'

→GX'Legend (boxes with text)' →GT200;1650;0;# OF CALLS'
→GB1;1700;1650;1750;1700;10
→GT1760;1700;0;' = BOYD'
→GB1;1700;1750;1750;1800;75
→GT1760;1800;0;' = GARY'
→GB1;1700;1850;1750;1900;50
→GT1760;1900;0;' = SHAWN'

→GX;Font Change Command' →Q4813
→GX'Title'
→GT500;1500;0;'SALES CALLS PER DAY'

→GX'Font Change Command' →Q4808
→GX'Subtitle'
→GT600;1550;0;'Week of:'
→GT900;1550;0;'March 24, 1995'
```

ADVANCED FEATURES

Linking Graphical Output to a Host Application

There are several ways to link the graphical output to a host application. One method is to simply add the IOGL commands to the application code. This means that whenever the application is used and sent to the printer, the IOGL commands are also sent.

Another method is to design a separate subroutine that sends the IOGL output to the printer as a macro. The IOGL macro will only be sent to the printer once and resides in the printer's active memory until the printer is powered down. The application code requires only a macro call and does not require the complete graphic to be downloaded when a report is printed.

To store the IOGL output as a printer macro, begin the IOGL routine with a PCL command that begins a macro by typing: **~E&f#y0X**

Substitute the # symbol with a number that identifies the macro. Make sure this command precedes all IOGL commands. Also, be aware that PCL is case sensitive.

At the end of the IOGL routine, stop the macro and save it permanently (until the printer is powered down) in the printer's memory. To end the macro type: **~E&f#y1X**

To save the macro permanently (until the printer is powered down) type: **~E&f#y10X**. Store this macro in the printer's memory by "printing it."

A call for this macro can be used in your application by embedding the following PCL command in the application code: **~E&f#y3X**

Another command that can be used to prevent overloading the printer's memory is **~E&f#y8X**. This command deletes the macro ID # that currently resides in the printer's memory.

Printing Images From The Host

It is often advantageous to include images such as company logos or signatures with printed output. Logos and other images can be stored on printer cartridges or "Flash" SIMMs. These products are offered through the printer manufacturer and/or various third party vendors. While the

ADVANCED FEATURES

process of loading the cartridge or SIMM differs, the final result is the same. The stored image is assigned a macro ID number that must be called up by the application when the image is to be printed. Please refer to the documentation supplied with the cartridge or SIMM for instructions on how to store an image.

Generally, a macro stored in non-volatile memory is called up by sending the command `^E&f#y3X` where # is the macro ID.

A PCL command used to reposition the stored image on a page is `^E&l#u#Z` where the first # (l#u) specifies the "Left Offset Registration" or horizontal movement in n/720 inch and the second # (#Z) specifies the "Top Offset Registration" or vertical movement of the image in n/720 inch.

The repositioning command must precede the macro call. To return to the original position, type `^E&10u0Z` immediately after the macro call.

6 PROBLEM RESOLUTION

This chapter provides instructions for performing diagnostic tests on the I-O Print Box. This chapter also contains a problem resolution guide that describes common problems with the interface or the printer and their solutions. If you are unable to solve a problem by following the procedures outlined in this chapter, contact your I-O dealer or I-O Customer Support.

Before calling, verify that the I-O Print Box is installed correctly, that the interface configuration settings are correct, perform the appropriate diagnostic tests outlined in this chapter, and have the following information ready:

- Printer and interface self-test printouts
- Model number and serial number of the interface
- Description of the problem
- Results of diagnostic tests
- Type of host system or controller

You may also need to print an EBCDIC hex dump by enabling the EBCDIC Hex Dump option through the interface's configuration switches. This causes all printing to be in hexadecimal EBCDIC code, just as it's received from the host, to help in tracing problems.

If it becomes necessary to ship the interface, use the original carton and packaging to prevent damage.

Interface Self-Test

Verify proper installation and configuration of the interface by performing an interface self-test. The self-test prints out the current software version, memory condition (RAM and ROM), and the current configuration selections.

PROBLEM RESOLUTION

Note: If you are operating a label printer put the printer in ASCII hex dump mode, then follow the self-test instructions below. If the label printer starts printing, the interface has passed the self-test. To obtain a printout of the current settings, connect the interface to a laser or dot-matrix printer.

The self-test can be started through Host/PC download command 98. Follow the steps below to start the self-test from your PC or terminal.

1. Verify that the printer is connected properly to the interface and in "Ready" mode.
2. Type "&%Z98,1" on the screen.
3. Send the Host/PC download command to the printer (i.e., press the Print Screen Button or print the document/file that contains the Host/PC download command). The self-test will print out in a few seconds.

Follow the steps below to start the self-test by setting the configuration switches.

1. Verify that the printer is connected properly to the interface.
2. Power off the printer interface.
3. Set configuration switch SW1:8 (far right on the first switch bank) to "|". Verify that configuration switches SW1:1 through SW1:3 are not all set to "|", but are set to a valid Twinax Address.
4. Power on the printer interface. A self-test will print within a few seconds after power up. After the self-test prints, the LED lights "Host Ready" and "Printer Ready" will begin blinking, indicating that the Print Box is not in operating mode.
5. Power off the interface and return configuration switch SW1:8 to the "o" position.

Sample printouts are shown beginning on page 2-5. The selections shown in the samples are factory defaults. The numbers at the left margin are command numbers used to change this setting using Host/PC download commands (see page 3-7).

PROBLEM RESOLUTION

If the test does not print, the interface failed the self-test. Contact your I-O Dealer or I-O Customer Support for more information.

EBCDIC Hex Dump

The interface can be set up to print the buffer in hexadecimal EBCDIC code. This can be useful for a technician to diagnose problems with the interface or the printer.

The EBCDIC hex data is printed on a grid corresponding to the data's position in the buffer. If the hex data represents a printable character, that character is printed below the hex data.

To start the EBCDIC Hex Dump through Host/PC Download:

1. Verify that the printer is connected properly to the interface.
2. Type "&%Z42,1" on the screen.
3. Send the Host/PC download command to the printer (press the Print Screen Button or print the document/file that contains the Host/PC download command).
4. To stop the Buffer Hex Dump, power OFF the interface.

Start the EBCDIC Hex Dump from the interface's front panel as follows:

1. With configuration switches SW1:1 through SW1:3 set to a valid Twinax Address (0-6), set configuration switch SW1:8 (far right on the first switch bank) to "|". The interface is now in buffer print mode.
2. Return configuration switch SW1:8 to the "o"-position after printing is completed.

PROBLEM RESOLUTION

ASCII Hex Dump

The interface can be set up to print the buffer in hexadecimal ASCII code. This differs from the EBCDIC hex dump in that the buffer is first translated into ASCII code before it is printed. This can be useful to diagnose problems with the interface or the printer. The ASCII Hex Dump can only be started through the interface's configuration switches. To start the ASCII Hex Dump:

1. Locate configuration switches SW1:4, SW1:5, SW1:6, and SW1:7 on the first switch bank.
2. Write down their current position ("o" or "|").
3. With the Print Box powered on, set configuration switches SW1:4, SW1:5, SW1:6, and SW1:7 to "|". The interface is now in ASCII Hex Dump mode.
4. To end ASCII Hex Dump mode, return the switches to their original position (see Step 2).

Self-Diagnostics

Warning: To avoid damage to your host system, the host must be disconnected from the adapter cable before running this test.

The interface can be set up to perform a complete analysis of its functions. The interface transmits data to itself and then analyzes how that data is processed. If an error is detected, an error message is printed on the printer. Diagnostic error messages are listed on page 6-5. Follow the steps below to perform interface self-diagnostics.

1. Power off the interface.
2. Disconnect the host cable from the adapter cable attached to the I-O Print Box.
3. Set configuration switches SW1:1 through SW1:3 and SW1:8 to "|".

PROBLEM RESOLUTION

4. Verify that the printer is connected properly to the interface and in "Ready" mode.
5. Power on the interface. The interface will start the self-diagnostics program and repeat it until it is powered off. After each completed self-diagnostic, the interface will send the following message to the printer:

TEST SEQUENCE COMPLETE

Because a laser printer will only print full pages, it will store these and other messages in the printer buffer until enough messages are accumulated to fill up one page. (This may take 3-4 minutes)

6. Power off the interface to end the self-diagnostics program.

Any error messages are printed between the "TEST SEQUENCE COMPLETE" messages. Call I-O Customer Support if error messages are printed.

Problem Resolution Guide

The following pages contain a general guide to resolve common problems that may occur. Please refer to this guide before contacting your I-O Customer Support representative.

PROBLEM RESOLUTION

| Problem or Message | Probable Cause | Action |
|---|--|--|
| Host Ready LED is not on when connected to the host | Host is not configured for a printer at the address specified | Make sure the host is properly configured for the printer |
| | Host is not operating | Check host system |
| | Damaged or improper cabling | Check host cabling for damage or improper connection |
| | Twinax cable improperly terminated | Make sure the prior device is not terminated (some PC emulator cards may terminate mid-line) |
| | Twisted pair cabling is not attached to an 'active' or boosted hub | Activate Star Panel Overdrive (front panel or host/PC download command 20) |
| Host Ready LED blinks on and off | Address conflict with another twinax device on the cable | Make sure no other devices on this cable have the same address |
| Printer Ready LED is off when printer is connected | Printer fault, such as paper out, paper jam, etc. | Make sure the printer has paper, is clear of jams, etc. |
| | Damaged or loose printer cable | Check printer cable for damage or improper connection |
| | Printer pinouts are incompatible with printer cable/I-O Print Box | Review the pin assignments on the printer's input port and the Print Box's output port |
| Printer loses host communication (drops off line) | Improper or damaged cabling | Check host cabling for improper connections or damage |
| | Twisted pair cabling is not attached to an 'active' or boosted hub | Activate Star Panel Overdrive (Host/PC download command 20) |

PROBLEM RESOLUTION

| Problem or Message | Probable Cause | Action |
|---|--|---|
| Right margin is cut off | Page width in word processing program is not set wide enough. | Reposition right margin setting. |
| | Page width is too wide | Select a narrower page. |
| Extra blank sheets are ejected between sheets of printout | Form length not correct in software (maximum length is 66 lines) | Make sure the document length doesn't exceed the maximum number of lines. |
| | Page orientation was changed | The printer may eject a blank page when the page orientation (portrait or landscape) is changed. |
| Form length is incorrect | Form length incorrect in software | Change form length. |
| | Incorrect configuration at the host | Make sure the host configuration matches the printer's |
| Printer won't change fonts | Incorrect typestyle number | Make sure the font ID used is valid. Invalid font IDs are ignored by the printer. |
| | Wrong font cartridge loaded | Load the cartridge with the font that corresponds to the font ID. |
| | Font cartridge damaged or not seated into the printer properly | If possible try a known good cartridge to determine if cartridge is faulty. Make sure the cartridge is loaded properly. |
| Printer does not print landscape in requested font | Did not select a rotation in the word processing program | Select 90° or 270° rotation in the program. |
| | Did not select a rotation in the data processing OCL statement. | Add a 90° or 270° orientation instruction to the OCL statement |

PROBLEM RESOLUTION

| Problem or Message | Probable Cause | Action |
|---|--|---|
| (Continued) | APO feature is ON and page size is 8 1/2" x 14" or less and width is less than height | Turn APO off or increase page size so it is larger than 8 1/2" x 14" or change width and height so width is greater than height. Refer to the Print Orientation section on page 4-10 for additional information. |
| | APO feature is OFF and orientation is set to COR; COR, host override; or portrait | Set I-O Print Box orientation to landscape. |
| Printer does not print portrait in requested font | Selected the wrong rotation in the word processing program | Select 0° to 180° rotation in OCL statement. |
| | Selected the wrong rotation in the date processing OCL statement | Select 0° to 180° rotation in OCL statement. |
| | APO feature is ON <u>and</u> page size is 8 1/2" x 14" or less <u>and</u> width is greater than height | Turn APO off <u>or</u> increase page size so it is larger than 8 1/2" x 14" <u>or</u> change width and height so width is less than height. Refer to the Print Orientation section on page 4-10 for additional information. |
| | APO feature is OFF <u>and</u> orientation is set to COR; COR, host override allowed; or landscape | Set I-O Print Box orientation to portrait. |
| Printer does not print COR | APO feature is ON <u>and</u> page size is 8 1/2" x 14" or less | Turn APO off <u>or</u> increase page size so it is larger than 8 1/2" x 14" |

PROBLEM RESOLUTION

| Problem or Message | Probable Cause | Action |
|---|---|--|
| (Continued) | APO feature is OFF and orientation is set to COR, host override allowed | Set orientation to COR or change host settings (see the Print Orientation section in Chapter 4). |
| | Rotation in data processing printer file is set to COR and host print quality in printer file is STD or NLQ | Select "DRAFT" print quality in printer file. |
| DisplayWrite/36 or OfficeVision/400 document prints incorrectly | There might be an error in using DisplayWrite/36 or Office Vision/400 | Choose "yes" to printer error log on page 3 of the Print Option Screen. |
| All LED's blink | Invalid emulation selected | Check manual for available emulations for your model of Print Box. |
| Printer ready light blinks (TxS plus) | Serial out parameters incorrect | Check serial parameters (baud rate, parity, word length, stop bits) |

PROBLEM RESOLUTION

This page left intentionally blank.

APPENDIX A

Font (FGID) Reference for PCL Compatible Printers

The following tables list standard resident fonts and cartridges that are available, along with the font ID number used to select the font.

For more information regarding font selection, refer to pages 4-3 and 4-5 (Laser Printer Operation, Font Change Commands) and page 5-3 (Advanced Features, User-Defined Fonts).

APPENDIX A

Below is a key for the character set in the Symbol column in the tables on the following pages:

L1 Latin 1 Euro character set
 R8 Roman 8 character set
 850 Code Page 850 character set

| Typeface | Symbol | Orient | Pitch | Point | Type-style No. |
|----------------|-----------|--------|-------|-------|----------------|
| Line Printer | L1/R8/850 | P/L | 13.33 | 8.5 | 204 |
| Line Printer | L1/R8/850 | P/L | 15 | 8.5 | 223 |
| Line Printer | L1/R8/850 | P/L | 17.1 | 8.5 | 254 |
| Line Printer | L1/R8/850 | P/L | 19 | 8.5 | 281 |
| Courier | L1/R8/850 | P/L | 10 | 12 | 11 |
| Courier Bold | L1/R8/850 | P/L | 10 | 12 | 46 |
| Courier Italic | L1/R8/850 | P/L | 10 | 12 | 18 |
| Courier | L1/R8/850 | P/L | 12 | 10 | 85 |
| Courier Bold | L1/R8/850 | P/L | 12 | 10 | 88 |
| Courier Italic | L1/R8/850 | P/L | 12 | 10 | 89 |
| Letter Gothic | L1/R8/850 | P/L | 12 | 12 | 87 |
| CG Times | L1/R8/850 | P/L | Prop. | 6 | 4605 |
| | L1/R8/850 | P/L | Prop. | 8 | 4606 |
| | L1/R8/850 | P/L | Prop. | 10 | 4607 |
| | L1/R8/850 | P/L | Prop. | 12 | 4608 |
| | L1/R8/850 | P/L | Prop. | 14 | 4609 |
| | L1/R8/850 | P/L | Prop. | 18 | 4611 |
| | L1/R8/850 | P/L | Prop. | 24 | 4614 |
| | L1/R8/850 | P/L | Prop. | 30 | 4617 |

APPENDIX A

| Typeface | Symbol | Orient | Pitch | Point | Type-style No. |
|----------------------|-----------|--------|-------|-------|----------------|
| CG Times Bold | L1/R8/850 | P/L | Prop. | 6 | 4625 |
| | L1/R8/850 | P/L | Prop. | 8 | 4626 |
| | L1/R8/850 | P/L | Prop. | 10 | 4627 |
| | L1/R8/850 | P/L | Prop. | 12 | 4628 |
| | L1/R8/850 | P/L | Prop. | 14 | 4629 |
| | L1/R8/850 | P/L | Prop. | 18 | 4631 |
| | L1/R8/850 | P/L | Prop. | 24 | 4634 |
| | L1/R8/850 | P/L | Prop. | 30 | 4637 |
| CG Times Italic | L1/R8/850 | P/L | Prop. | 6 | 4645 |
| | L1/R8/850 | P/L | Prop. | 8 | 4646 |
| | L1/R8/850 | P/L | Prop. | 10 | 4647 |
| | L1/R8/850 | P/L | Prop. | 12 | 4648 |
| | L1/R8/850 | P/L | Prop. | 14 | 4649 |
| | L1/R8/850 | P/L | Prop. | 18 | 4651 |
| | L1/R8/850 | P/L | Prop. | 24 | 4654 |
| | L1/R8/850 | P/L | Prop. | 30 | 4657 |
| CG Times Bold Italic | L1/R8/850 | P/L | Prop. | 6 | 4665 |
| | L1/R8/850 | P/L | Prop. | 8 | 4666 |
| | L1/R8/850 | P/L | Prop. | 10 | 4667 |
| | L1/R8/850 | P/L | Prop. | 12 | 4668 |
| | L1/R8/850 | P/L | Prop. | 14 | 4669 |
| | L1/R8/850 | P/L | Prop. | 18 | 4671 |
| | L1/R8/850 | P/L | Prop. | 24 | 4674 |
| | L1/R8/850 | P/L | Prop. | 30 | 4677 |

APPENDIX A

| Typeface | Symbol | Orient | Pitch | Point | Type-style No. |
|-----------------------|-----------|--------|-------|-------|----------------|
| Univer Medium | L1/R8/850 | P/L | Prop. | 6 | 4805 |
| | L1/R8/850 | P/L | Prop. | 8 | 4806 |
| | L1/R8/850 | P/L | Prop. | 10 | 4807 |
| | L1/R8/850 | P/L | Prop. | 12 | 4808 |
| | L1/R8/850 | P/L | Prop. | 14 | 4809 |
| | L1/R8/850 | P/L | Prop. | 18 | 4811 |
| | L1/R8/850 | P/L | Prop. | 24 | 4812 |
| | L1/R8/850 | P/L | Prop. | 30 | 4813 |
| Univers Med Italic | L1/R8/850 | P/L | Prop. | 6 | 4825 |
| | L1/R8/850 | P/L | Prop. | 8 | 4826 |
| | L1/R8/850 | P/L | Prop. | 10 | 4827 |
| | L1/R8/850 | P/L | Prop. | 12 | 4828 |
| | L1/R8/850 | P/L | Prop. | 14 | 4829 |
| | L1/R8/850 | P/L | Prop. | 18 | 4831 |
| | L1/R8/850 | P/L | Prop. | 24 | 4834 |
| | L1/R8/850 | P/L | Prop. | 30 | 4837 |
| Univers Med Condensed | L1/R8/850 | P/L | Prop. | 6 | 4845 |
| | L1/R8/850 | P/L | Prop. | 8 | 4846 |
| | L1/R8/850 | P/L | Prop. | 10 | 4847 |
| | L1/R8/850 | P/L | Prop. | 12 | 4848 |
| | L1/R8/850 | P/L | Prop. | 14 | 4849 |
| | L1/R8/850 | P/L | Prop. | 18 | 4851 |
| | L1/R8/850 | P/L | Prop. | 24 | 4854 |
| | L1/R8/850 | P/L | Prop. | 30 | 4857 |

APPENDIX A

| Typeface | Symbol | Orient. | Pitch | Point | Type-style No. |
|---------------------------------|-----------|---------|-------|-------|----------------|
| Univers Med Cond. Italic | L1/R8/850 | P/L | Prop. | 6 | 4865 |
| | L1/R8/850 | P/L | Prop. | 8 | 4866 |
| | L1/R8/850 | P/L | Prop. | 10 | 4867 |
| | L1/R8/850 | P/L | Prop. | 12 | 4868 |
| | L1/R8/850 | P/L | Prop. | 14 | 4869 |
| | L1/R8/850 | P/L | Prop. | 18 | 4871 |
| | L1/R8/850 | P/L | Prop. | 24 | 4874 |
| | L1/R8/850 | P/L | Prop. | 30 | 4877 |
| ITC Zapf Dingbat | 14L | P/L | Prop. | 6 | 4985 |
| | 14L | P/L | Prop. | 8 | 4986 |
| | 14L | P/L | Prop. | 10 | 4987 |
| | 14L | P/L | Prop. | 12 | 4988 |
| | 14L | P/L | Prop. | 14 | 4989 |
| | 14L | P/L | Prop. | 18 | 4991 |
| | 14L | P/L | Prop. | 24 | 4994 |
| | 14L | P/L | Prop. | 30 | 4997 |
| General Font Assignments | | | | | |
| Times | L1/R8/850 | P | Prop. | 8 | 157 |
| Times | L1/R8/850 | P | Prop. | 10 | 158 |
| Times Bold | L1/R8/850 | P | Prop. | 10 | 159 |
| Times Italic | L1/R8/850 | P | Prop. | 10 | 155 |
| Helvetica Bold | L1/R8/850 | P | Prop. | 14.4 | 34126 |
| Courier Bold | L1/R8/850 | P/L | 10 | 12 | 46 |
| Courier Italic | L1/R8/850 | P/L | 10 | 12 | 18 |
| Prestige | L1/R8/850 | P/L | 12 | 10 | 86 |
| Prestige Bold | L1/R8/850 | P/L | 12 | 10 | 111 |
| Prestige Italic | L1/R8/850 | P/L | 12 | 10 | 112 |

APPENDIX A

| Typeface | Symbol | Orient. | Pitch | Point | Type-style No. |
|---------------------------------|-----------|---------|-------|-------|----------------|
| General Font Assignments | | | | | |
| Letter Gothic | L1/R8/850 | P/L | 12 | 12 | 87 |
| Letter Gothic Bold | L1/R8/850 | P/L | 12 | 12 | 110 |
| Letter Gothic Italic | L1/R8/850 | P/L | 12 | 10 | 112 |
| Helvetica | ASCII | P | Prop. | 6 | 181 |
| Helvetica | ASCII | P | Prop. | 8 | 183 |
| Helvetica Bold | ASCII | P | Prop. | 8 | 182 |
| Helvetica Bold | ASCII | P | Prop. | 10 | 185 |
| Helvetica Bold | ASCII | P | Prop. | 12 | 188 |
| Helvetica Bold | ASCII | P | Prop. | 14 | 190 |
| Tax Line Draw | LinDrw-7 | P | 10 | 12 | 34 |
| Letter Gothic | L1/R8/850 | P | 10 | 14.4 | 40 |
| Letter Gothic | L1/R8/850 | P | 17.1 | 9.4 | 255 |
| OCR-A 10N | OCR-A | P | 10 | 12 | 19 |
| OCR-B 10N | OCR-B | P | 10 | 12 | 3 |
| Code 3-9 4.6N | 3 of 9 | P | 4.6 | 12 | 240 |
| Code 3-9 9.3N | 3 of 9 | P | 9.3 | 12 | 61 |
| EAN/UPC Bold Bar Code | UPC | P | Prop. | 12 | 171 |
| EAN/UPC Bar Code | UPC | P | Prop. | 12 | 170 |
| ProCollection Cartridge | | | | | |
| Line Printer | ASCII | P/L | 17.1 | 8.5 | 253 |
| Courier Bold | ASCII | P/L | 10 | 12 | 45 |
| Courier Italic | ASCII | P/L | 10 | 12 | 17 |
| Courier | ASCII | P/L | 12 | 10 | 85 |
| Courier Bold | ASCII | P/L | 12 | 10 | 108 |

APPENDIX A

| Typeface | Symbol | Orient. | Pitch | Point | Type-style No. |
|--|--------|---------|-------|-------|----------------|
| ProCollection Cartridge (cont.) | | | | | |
| Courier Italic | ASCII | P/L | 12 | 10 | 92 |
| Courier | Legal | P | 10 | 12 | 51 |
| Couier Bold | Legal | P | 10 | 12 | 52 |
| Courier Italic | Legal | P | 10 | 10 | 53 |
| Courier | Legal | P | 12 | 10 | 93 |
| Courier Bold | Legal | P | 12 | 10 | 94 |
| Courier Italic | Legal | P | 12 | 10 | 95 |
| Prestige Elite | ASCII | P/L | 15 | 7 | 220 |
| Prestige Elite | ASCII | P/L | 12 | 10 | 83 |
| Prestige Elite Bold | ASCII | P/L | 12 | 10 | 113 |
| Prestige Elite Italic | ASCII | P/L | 12 | 10 | 114 |
| Prestige Elite | Legal | P | 15 | 7 | 219 |
| Prestige Elite | Legal | P | 12 | 10 | 97 |
| Prestige Elite Bold | Legal | P | 12 | 10 | 98 |
| Prestige Elite Italic | Legal | P | 12 | 10 | 99 |
| Letter Gothic | ASCII | P/L | 27 | 3.6 | 291 |
| Letter Gothic | ASCII | P/L | 19 | 6 | 281 |
| Letter Gothic | ASCII | P/L | 17.1 | 9.5 | 257 |
| Letter Gothic | ASCII | P/L | 12 | 12 | 66 |
| Letter Gothic Bold | ASCII | P/L | 12 | 12 | 69 |
| Letter Gothic Italic | ASCII | P/L | 12 | 12 | 68 |
| Times Roman | ASCII | P | Prop. | 8 | 163 |
| Times Roman | ASCII | P | Prop. | 10 | 164 |

APPENDIX A

| Typeface | Symbol | Orient | Pitch | Point | Type-style No. |
|------------------------------|--------|--------|-------|-------|----------------|
| Times Roman Bold | ASCII | P | Prop. | 10 | 165 |
| Times Roman Italic | ASCII | P | Prop. | 10 | 166 |
| Times Roman | ASCII | P | Prop. | 12 | 167 |
| Times Roman Bold | ASCII | P | Prop. | 12 | 168 |
| Times Roman Italic | ASCII | P | Prop. | 12 | 169 |
| Times Roman | Legal | P | Prop. | 8 | 173 |
| Times Roman | Legal | P | Prop. | 10 | 174 |
| Times Roman Bold | Legal | P | Prop. | 10 | 175 |
| Times Roman Italic | Legal | P | Prop. | 10 | 176 |
| Times Roman | Legal | P | Prop. | 12 | 177 |
| Times Roman Bold | Legal | P | Prop. | 12 | 178 |
| Times Roman Italic | Legal | P | Prop. | 12 | 179 |
| Helvetica | ASCII | P | Prop. | 8 | 183 |
| Helvetica | ASCII | P | Prop. | 10 | 184 |
| Helvetica Bold | ASCII | P | Prop. | 10 | 185 |
| Helvetica Italic | ASCII | P | Prop. | 10 | 186 |
| Helvetica | ASCII | P | Prop. | 12 | 187 |
| Helvetic Bold | ASCII | P | Prop. | 12 | 188 |
| Helvetica Italic | ASCII | P | Prop. | 12 | 189 |
| Helvetica Bold | ASCII | P | Prop. | 14 | 190 |
| Helvetica Bold | Legal | P | Prop. | 14 | 191 |
| WordPerfect Cartridge | | | | | |
| CG Times | DskTop | P | Prop. | 6 | 4685 |
| CG Times | DskTop | P | Prop. | 8 | 4686 |

APPENDIX A

| Typeface | Symbol | Orient | Pitch | Point | Type- style No. |
|----------------------------|--------|--------|-------|-------|-----------------------|
| CG Times Bold | DskTop | P | Prop. | 8 | 4706 |
| CG Times Italic | DskTop | P | Prop. | 8 | 4814 |
| CG Times | DskTop | P | Prop. | 10 | 4687 |
| CG Times Bold | DskTop | P | Prop. | 10 | 4707 |
| CG Times Italic | DskTop | P | Prop. | 10 | 4815 |
| CG Times | DskTop | P | Prop. | 12 | 4688 |
| CG Times Bold | DskTop | P | Prop. | 12 | 4708 |
| CG Times Italic | DskTop | P | Prop. | 12 | 4816 |
| CG Times | DskTop | P | Prop. | 14 | 4689 |
| CG Times Bold | DskTop | P | Prop. | 14 | 4709 |
| CG Times Italic | DskTop | P | Prop. | 14 | 4817 |
| CG Times Bold | DskTop | P | Prop. | 18 | 4711 |
| CG Times Bold | DskTop | P | Prop. | 24 | 4714 |
| Univers | DskTop | P | Prop. | 14 | 4789 |
| Univers | DskTop | P | Prop. | 18 | 4791 |
| Univers | DskTop | P | Prop. | 24 | 4794 |
| Microsoft Cartridge | | | | | |
| Helvetica | L1/R8 | P | Prop. | 8 | 34102 |
| Helvetica | L1/R8 | P | Prop. | 10 | 34103 |
| Helvetica Bold | L1/R8 | P | Prop. | 10 | 34123 |
| Helvetica Italic | L1/R8 | P | Prop. | 10 | 34231 |
| Helvetica | L1/R8 | P | Prop. | 12 | 34104 |
| Helvetic Bold | L1/R8 | P | Prop. | 12 | 34124 |
| Helvetica Italic | L1/R8 | P | Prop. | 12 | 34232 |
| Helv Bold | L1/R8 | P | Prop. | 14 | 34125 |

APPENDIX A

| Typeface | Symbol | Orient | Pitch | Point | Type-style No. |
|-------------------------------------|-----------|--------|-------|-------|----------------|
| TmsRmn | L1/R8 | P | Prop. | 8 | 5686 |
| TmsRmn | L1/R8 | P | Prop. | 10 | 5687 |
| TmsRmn Bold | L1/R8 | P | Prop. | 10 | 5707 |
| TmsRmn Italic | L1/R8 | P | Prop. | 10 | 5815 |
| Times Roman | L1/R8 | P | Prop. | 12 | 5688 |
| Times Roman Bold | L1/R8 | P | Prop. | 12 | 5708 |
| Times Roman Italic | L1/R8 | P | Prop. | 12 | 5816 |
| Times Roman Bold | L1/R8 | P | Prop. | 14 | 5709 |
| Line Printer | L1/R8 | P | Prop. | 835 | 223 |
| Polished Worksheet Cartridge | | | | | |
| Prestige Elite | L1/R8/850 | P/L | 15 | 7 | 221 |
| Prestige Elite | L1/R8/850 | P/L | 12 | 10 | 86 |
| Prestige Elite Bold | L1/R8/850 | P/L | 12 | 10 | 111 |
| Prestige Elite Italic | L1/R8/850 | P/L | 12 | 10 | 112 |
| Prestige Elite | Legal | P/L | 15 | 7 | 219 |
| Prestige Elite | Legal | P/L | 12 | 10 | 97 |
| Prestige Elite Bold | Legal | P/L | 12 | 10 | 98 |
| Prestige Elite Italic | Legal | P/L | 12 | 10 | 99 |
| Letter Gothic | L1/R8 | P/L | 27 | 3.6 | 290 |
| Letter Gothic | L1/R8/850 | P/L | 12 | 12 | 87 |
| Letter Gothic Bold | L1/R8/850 | P/L | 12 | 12 | 110 |
| Letter Gothic Italic | Legal | P/L | 12 | 12 | 109 |
| Letter Gothic | Legal | P/L | 27 | 3.6 | 292 |
| Letter Gothic | Legal | P/L | 12 | 12 | 90 |
| Letter Gothic Bold | Legal | P/L | 12 | 12 | 107 |
| Letter Gothic Italic | Legal | P/L | 12 | 12 | 106 |

APPENDIX A

| Typeface | Symbol | Orient | Pitch | Point | Type-style No. |
|---|-----------|--------|-------|-------|----------------|
| Presentation Bold | ASCII | P/L | 8.1 | 16 | 434 |
| Presentation Bold | Legal | P/L | 8.1 | 16 | 431 |
| Persuasive Presentations Cartridge | | | | | |
| Letter Gothic | ASCII | P/L | 10 | 14 | 39 |
| Letter Gothic | Legal | P/L | 10 | 14 | 38 |
| Presentation Bold | ASCII | P/L | 10 | 14 | 6 |
| Presentation Bold | Legal | P/L | 10 | 14 | 7 |
| Presentation bold | ASCII | P/L | 8.1 | 16 | 434 |
| Presentation bold | Legal | P/L | 8.1 | 16 | 431 |
| Presentation bold | ASCII | P/L | 6.5 | 18 | 435 |
| Presentation bold | Legal | P/L | 6.5 | 18 | 432 |
| Presentation bold | ASCII | P/L | 5.7 | 24 | 436 |
| Presentation bold | Legal | P/L | 5.7 | 24 | 433 |
| Helv Outline | ASCII | P/L | Prop. | 24 | 34115 |
| Helv Outline | Legal | P/L | Prop. | 24 | 34116 |
| Serifa | ASCII | P/L | Prop. | 24 | 34215 |
| Serifa | Legal | P/L | Prop. | 24 | 34216 |
| Line Draw | LinDrw | P/L | 10 | 14 | 31 |
| PC Line bold | PCLin | P/L | 10 | 14 | 32 |
| Forms, Etc. Cartridge | | | | | |
| Univers | L1/R8/850 | P/L | Prop. | 6 | 33101 |
| Univers | L1/R8/850 | P/L | Prop. | 8 | 33102 |
| Univers bold | L1/R8/850 | P/L | Prop. | 8 | 33122 |
| Univers bold | L1/R8/850 | P/L | Prop. | 10 | 33123 |
| Univers bold | L1/R8/850 | P/L | Prop. | 12 | 33124 |
| Univers bold | L1/R8/850 | P/L | Prop. | 14 | 33125 |
| Helv Cond. Black bold | TXNum | P/L | Prop. | 24 | 34128 |
| OCR-A | OCR-A | P | 10 | 12 | 19 |

APPENDIX A

| Typeface | Symbol | Orient | Pitch | Point | Type-style No. |
|---------------------------------------|------------|--------|-------|-------|----------------|
| Tax Line Draw | Taxlin Drw | P/L | 10 | 12 | 30 |
| Bar Codes & More Cartridge | | | | | |
| Letter Gothic | L1/R8 | P/L | 15 | 9.5 | 230 |
| Letter Gothic | L1/R8 | P/L | 112 | 12 | 87 |
| Letter Gothic | L1/R8 | P/L | 10 | 14 | 40 |
| OCR-A | OCR-A | P | 10 | 12 | 19 |
| OCR-B | OCR-B | P | 10 | 12 | 3 |
| Code 3 of 9 | 3 of 9 | P | 8.1 | 12 | 60 |
| Code 3 of 9 | 3 of 9 | P | 4.6 | 12 | 240 |
| EAN/UPC 10 Mil | UPC | P | Prop. | 12 | 170 |
| EAN/UPC 13 Mil bold | UPC | P | Prop. | 12 | 171 |
| USPS Zip | ZIP | P/L | Prop. | 12 | 172 |
| Line Draw | LinDrw | P/L | 10 | 12 | 33 |
| Text Equations Cartridge | | | | | |
| Prestige Elite | L1/R8 | P | 15 | 7 | 221 |
| Prestige Elite | L1/R8 | P | 17.1 | 7 | 256 |
| Prestige Elite | L1/R8 | P | 12 | 10 | 86 |
| Prestige Elite bold | L1/R8 | P | 12 | 10 | 111 |
| Prestige Elite italic | L1/R8 | P | 12 | 10 | 112 |
| CG Times | L1/R8 | P | Prop. | 8 | 157 |
| CG Times | L1/R8 | P | Prop. | 10 | 158 |
| CG Times bold | L1/R8 | P | Prop. | 10 | 159 |
| CG Times italic | L1/R8 | P | Prop. | 10 | 155 |
| Global Text Cartridge | | | | | |
| CG Century Schoolbook | L1/R8/850 | P/L | Prop. | 8 | 16950 |
| CG Century Schoolbook | L1/R8/850 | P/L | Prop. | 10 | 16951 |
| CG Century Schlbk Bold | L1/R8/850 | P/L | Prop. | 10 | 16971 |
| CG Century Schlbk Italic | L1/R8/850 | P/L | Prop. | 10 | 17079 |

APPENDIX A

| Typeface | Symbol | Orient. | Pitch | Point | Type-style No. |
|---|--------|---------|-------|-------|----------------|
| CG Triumvirate | L1/R8 | P/L | Prop. | 10 | 33335 |
| CG Triumvirate Bold | L1/R8 | P/L | Prop. | 14 | 33357 |
| Optional Fonts as originally found in Pretty Faces Cartridge | | | | | |
| Microstyle | ASCII | P | Prop. | 18 | 5910 |
| Microstyle Bold | ASCII | P | Prop. | 36 | 5920 |
| Hobo Medium | ASCII | P | Prop. | 30 | 5930 |
| Hobo Medium | ASCII | P | Prop. | 14 | 5940 |
| Thunderbird | ASCII | P | Prop. | 54 | 5950 |
| Signet Roundhand | ASCII | P | Prop. | 18 | 5960 |
| Signet Roundhand | ASCII | P | Prop. | 14 | 5970 |
| ITC Dingbats | ITC | P | Prop. | 36 | 5980 |
| ITC Dingbats | ITC | P | Prop. | 18 | 5990 |

APPENDIX A

This page left intentionally blank.

APPENDIX B**Resident Scalable Font Numbers**

The following is a list of the resident scalable fonts and font numbers for current PCL compatible printers. Refer to page 4-5 "Font Change Commands" to implement resident scalable font changes.

Fonts with ID numbers 410 through 490 are fixed pitch fonts. All others are proportional fonts.

| Font | Font ID No. |
|----------------------|--------------------|
| Letter Gothic | 410 |
| Letter Gothic bold | 420 |
| Letter Gothic italic | 430 |
| Courier | 460 |
| Courier bold | 470 |
| Courier italic | 480 |
| Courier bold italic | 490 |
| Symbol | 3400 |
| Symbol PS | 3450 |
| Wingdings | 3500 |
| Dingbats | 3600 |
| CG Omega | 4919 |
| CG Omega bold | 4939 |
| CG Omega italic | 5047 |
| CG Omega bold italic | 5067 |
| CG Times | 5687 |
| CG Times bold | 5707 |
| CG Times italic | 5815 |
| CG Times bold italic | 5835 |
| Arial | 6199 |
| Arial bold | 6219 |

APPENDIX B

| Font | Font ID No. |
|---------------------------------|-------------|
| Arial italic | 6327 |
| Arial bold italic | 6347 |
| Garamond Antiqua | 8503 |
| Garamond Halbfett | 8523 |
| Garamond Kursiv | 8631 |
| Garamond Kursiv Halbfett | 8651 |
| Coronet | 8759 |
| Clarendon condensed | 8779 |
| Marigold | 8887 |
| Albertus medium | 12855 |
| Albertus extra bold | 12875 |
| Times New | 16951 |
| Times New bold | 16971 |
| Times New italic | 17079 |
| Times New bold italic | 17099 |
| Antique Olive | 33335 |
| Antique Olive bold | 33355 |
| Antique Olive italic | 33463 |
| Univers medium condensed | 33591 |
| Univers bold condensed | 33601 |
| Univers medium condensed italic | 33719 |
| Univers bold condensed italic | 33729 |
| Univers medium | 34103 |
| Univers bold | 34123 |
| Univers medium italic | 34231 |
| Univers bold italic | 34251 |

APPENDIX B

| Font | Font ID No. |
|-------------------------------------|-------------|
| Helvetica | 33103 |
| Helvetica bold | 33123 |
| Helvetica Oblique | 33231 |
| Helvetica Oblique bold | 38251 |
| Helvetica Narrow | 31103 |
| Helvetica Narrow bold | 31123 |
| Helvetica Narrow Oblique | 31231 |
| Helvetica Narrow Oblique bold | 31251 |
| Palatino Roman | 6099 |
| Palatino bold | 6119 |
| Palatino italic | 6227 |
| Palatino bold italic | 6247 |
| ITC Avant Garde Gothic Book | 32591 |
| ITC Avant Garde Gothic Demi | 32601 |
| ITC Avant Garde Gothic Book Oblique | 32719 |
| IC Avant Garde Gothic Demi Oblique | 32729 |
| ITC Bookman Light | 4909 |
| ITC Bookman Demi | 4929 |
| ITC Bookman Light italic | 5037 |
| ITC Bookman Demi italic | 5057 |
| New Century Schoolbook Roman | 16941 |
| New Century Schoolbook bold | 16961 |
| New Century Schoolbook italic | 17069 |
| New Century Schoolbook bold italic | 17089 |

APPENDIX B

| Font | Font ID No. |
|--|-------------|
| 3812 Font Numbers which use the CG Times Typeface | |
| Sonoran-Serif | 751 |
| Sonoran-Serif | 1051 |
| Sonoran-Serif bold | 1053 |
| Sonoran-Serif italic | 1056 |
| Sonoran-Serif | 1351 |
| Sonoran-Serif bold | 1653 |
| Sonoran-Serif bold | 2103 |

APPENDIX C

Character Sets

An EBCDIC to ASCII translation table is printed at the bottom of the interface self-test printout as shown on page 2-7. This table illustrates how EBCDIC characters (from the twinax host) are converted to the ASCII characters in Code Page 850, Code Page 858, Roman 8, and Code Page 437 and Windows 3.1 Latin 1 character sets.

The first digit of the EBCDIC hex code is at the top of the table, and the second digit is on the left side. The corresponding ASCII hex code is where the two digits intersect. The character that corresponds to the ASCII hex code is the chart to the right.

For example, EBCDIC 61 is translated to ASCII 2F, which is a “/” character.

Characters in the following ASCII tables can be obtained by embedding the ASCII hex value for that character in a host document in the following manner:

```
&%<hex pair> <additional hex pairs>&%
```

where &% are the Command Pass-Thru Delimiters <hex pair> is the ASCII hex value for the desired character <additional hex pairs> are the ASCII values for additional characters. Each hex pair can be separated with a space to aid in readability. However, there must not be a space between the Command Pass-Thru delimiters and the first hex pair. Spaces between hex values of a hex pair are also not allowed.

Example: To print ASCII character ö using the Code Page 850 character set, first locate the corresponding ASCII hex value. It is 94. Then embed the ASCII hex value together with the Command Pass-Thru delimiters in your host document:

```
J&%94&%rg
```

will print as Jörg, a common first name in Germany.

Note that some ASCII printers use slightly modified tables. You should consult your printer’s User Guide for more information on printable and non-printable characters.

APPENDIX C

Code Page 850 Symbol Set

| | 0 | 1 | 2 | 3 | 4 | 5 | 6 | 7 | 8 | 9 | A | B | C | D | E | F |
|---|----------|----------|----------|---------|---------|---------|----------|----------|----------|----------|---------------------|----------|----------|----------|----------|----------|
| 0 | NUL 0 | ▶ 16 | | 0 48 | @ 64 | P 80 | ` 96 | p 112 | Ç 128 | É 144 | á 160 | ☐ 176 | └ 192 | ð 208 | Ó 224 | - 240 |
| 1 | ☺ 1 | ◀ 17 | ! 33 | 1 49 | A 65 | Q 81 | a 97 | q 113 | ü 129 | æ 145 | í 161 | ☒ 177 | ┌ 193 | Ð 209 | ß 225 | ± 241 |
| 2 | ☻ 2 | ↕ 18 | " 34 | 2 50 | B 66 | R 82 | b 98 | r 114 | é 130 | Æ 146 | ó 162 | ☒ 178 | ┘ 194 | Ê 210 | Ô 226 | = 242 |
| 3 | ♥ 3 | !! 19 | # 35 | 3 51 | C 67 | S 83 | c 99 | s 115 | â 131 | ô 147 | ú 163 | ┆ 179 | ┆ 195 | Ë 211 | Ò 227 | ¼ 243 |
| 4 | ♦ 4 | ¶ 20 | \$ 36 | 4 52 | D 68 | T 84 | d 100 | t 116 | ä 132 | ö 148 | ñ 164 | ┆ 180 | — 196 | È 212 | õ 228 | ¶ 244 |
| 5 | ♣ 5 | § 21 | % 37 | 5 53 | E 69 | U 85 | e 101 | u 117 | à 133 | ò 149 | Ñ 165 | Á 181 | ⊕ 197 | ı 213 | Ö 229 | § 245 |
| 6 | ♠ 6 | — 22 | & 38 | 6 54 | F 70 | V 86 | f 102 | v 118 | â 134 | û 150 | ^a 166 | Â 182 | ã 198 | Í 214 | μ 230 | ÷ 246 |
| 7 | ● 7 | ↕ 23 | ' 39 | 7 55 | G 71 | W 87 | g 103 | w 119 | ç 135 | ù 151 | ° 167 | À 183 | Ã 199 | Î 215 | þ 231 | ↳ 247 |
| 8 | ◼ 8 | ↑ 24 | (40 | 8 56 | H 72 | X 88 | h 104 | x 120 | ê 136 | ÿ 152 | ı 168 | © 184 | └ 200 | İ 216 | þ 232 | ° 248 |
| 9 | ○ 9 | ↓ 25 |) 41 | 9 57 | I 73 | Y 89 | i 105 | y 121 | ë 137 | Ö 153 | ® 169 | ≡ 185 | ≡ 201 | ┘ 217 | Ú 233 | ¨ 249 |
| A | ◼ 10 | → 26 | * 42 | : 58 | J 74 | Z 90 | j 106 | z 122 | è 138 | Û 154 | ¬ 170 | ≡ 186 | ≡ 202 | ┘ 218 | Û 234 | · 250 |
| B | ♂ 11 | ← 27 | + 43 | ; 59 | K 75 | [91 | k 107 | { 123 | ï 139 | ø 155 | ½ 171 | ≡ 187 | ≡ 203 | ◼ 219 | Ü 235 | ¹ 251 |
| C | ♀ 12 | └ 28 | , 44 | < 60 | L 76 | \ 92 | l 108 | l 124 | î 140 | £ 156 | ¼ 172 | ≡ 188 | ≡ 204 | ◼ 220 | Ý 236 | ³ 252 |
| D | 🎵 13 | ↔ 29 | - 45 | = 61 | M 77 | J 93 | m 109 | } 125 | ì 141 | Ø 157 | ı 173 | ¢ 189 | ≡ 205 | ı 221 | Ÿ 237 | ² 253 |
| E | 🎵 14 | ▲ 30 | . 46 | > 62 | N 78 | ^ 94 | n 110 | ~ 126 | Ä 142 | × 158 | « 174 | ¥ 190 | ≡ 206 | ı 222 | — 238 | ◼ 254 |
| F | ☼ 15 | ▼ 31 | / 47 | ? 63 | O 79 | _ 95 | o 111 | ⏏ 127 | Å 143 | f 159 | » 175 | └ 191 | ¤ 207 | ◼ 223 | ´ 239 | |

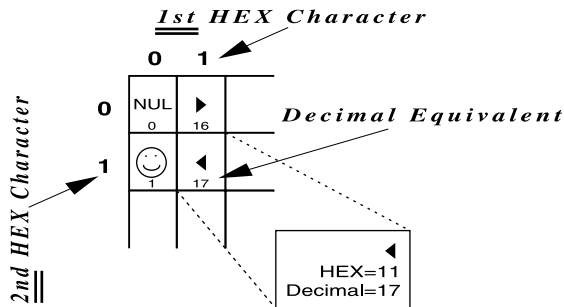

APPENDIX C

Code Page 858 Symbol Set

| | 0 | 1 | 2 | 3 | 4 | 5 | 6 | 7 | 8 | 9 | A | B | C | D | E | F |
|---|----------|----------|----------|---------|---------|---------|----------|----------|----------|----------|----------|----------|----------|----------|----------|----------|
| 0 | NUL 0 | ▶ 16 | | 0 48 | @ 64 | P 80 | ˘ 96 | p 112 | Ç 128 | É 144 | á 160 | ☒ 176 | ⊥ 192 | ð 208 | Ó 224 | - 240 |
| 1 | ☺ 1 | ◀ 17 | ! 33 | 1 49 | A 65 | Q 81 | a 97 | q 113 | ü 129 | æ 145 | í 161 | ☒ 177 | ⊥ 193 | Ð 209 | β 225 | ± 241 |
| 2 | ☻ 2 | ↕ 18 | " 34 | 2 50 | B 66 | R 82 | b 98 | r 114 | é 130 | Æ 146 | ó 162 | ☒ 178 | ⊥ 194 | Ê 210 | Ô 226 | = 242 |
| 3 | ♥ 3 | !! 19 | # 35 | 3 51 | C 67 | S 83 | c 99 | s 115 | â 131 | ô 147 | ú 163 | 179 | ⊥ 195 | Ë 211 | Ò 227 | ¾ 243 |
| 4 | ♦ 4 | ¶ 20 | \$ 36 | 4 52 | D 68 | T 84 | d 100 | t 116 | ä 132 | ö 148 | ñ 164 | ⊥ 180 | — 196 | È 212 | õ 228 | ¶ 244 |
| 5 | ♣ 5 | § 21 | % 37 | 5 53 | E 69 | U 85 | e 101 | u 117 | à 133 | ò 149 | Ñ 165 | Á 181 | ⊥ 197 | € 213 | Õ 229 | § 245 |
| 6 | ♠ 6 | — 22 | & 38 | 6 54 | F 70 | V 86 | f 102 | v 118 | â 134 | û 150 | ª 166 | Â 182 | ã 198 | Í 214 | µ 230 | ÷ 246 |
| 7 | ● 7 | ↕ 23 | ' 39 | 7 55 | G 71 | W 87 | g 103 | w 119 | ç 135 | ù 151 | º 167 | À 183 | Ã 199 | Î 215 | þ 231 | ¸ 247 |
| 8 | ◻ 8 | ↑ 24 | (40 | 8 56 | H 72 | X 88 | h 104 | x 120 | ê 136 | ÿ 152 | ı 168 | © 184 | ⊥ 200 | Ï 216 | ƒ 232 | ° 248 |
| 9 | ○ 9 | ↓ 25 |) 41 | 9 57 | I 73 | Y 89 | i 105 | y 121 | ë 137 | ÿ 153 | ® 169 | ≡ 185 | ⊥ 201 | ⊥ 217 | Ú 233 | ¨ 249 |
| A | ◼ 10 | → 26 | * 42 | : 58 | J 74 | Z 90 | j 106 | z 122 | è 138 | Û 154 | ¬ 170 | ≡ 186 | ⊥ 202 | ⊥ 218 | Û 234 | · 250 |
| B | ♂ 11 | ← 27 | + 43 | ; 59 | K 75 | [91 | k 107 | { 123 | ï 139 | ø 155 | ½ 171 | ⊥ 187 | ⊥ 203 | ■ 219 | Ù 235 | ¹ 251 |
| C | ♀ 12 | ⊥ 28 | , 44 | < 60 | L 76 | \ 92 | l 108 | 124 | î 140 | £ 156 | ¼ 172 | ⊥ 188 | ⊥ 204 | ■ 220 | Ý 236 | ³ 252 |
| D | 🎵 13 | ↔ 29 | - 45 | = 61 | M 77 |] 93 | m 109 | } 125 | ì 141 | Ø 157 | ı 173 | ¢ 189 | ≡ 205 | ⊥ 221 | Ý 237 | ² 253 |
| E | 🎵 14 | ▲ 30 | . 46 | > 62 | N 78 | ^ 94 | n 110 | ~ 126 | Ä 142 | × 158 | « 174 | ¥ 190 | ⊥ 206 | Ï 222 | — 238 | ■ 254 |
| F | ☼ 15 | ▼ 31 | / 47 | ? 63 | O 79 | _ 95 | o 111 | ⏏ 127 | Å 143 | f 159 | » 175 | ⊥ 191 | ⊥ 207 | ■ 223 | ´ 239 | |

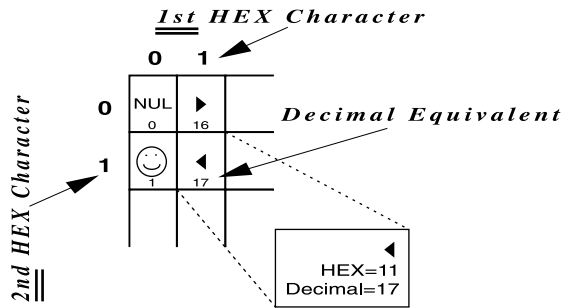

APPENDIX C

Roman-8 Symbol Set

Includes US ASCII (dec. 1-127) and Roman Extension Symbol Sets

| | 0 | 1 | 2 | 3 | 4 | 5 | 6 | 7 | 8 | 9 | A | B | C | D | E | F | |
|---|----------|-----------|----------|---------|---------|---------|----------|----------|---|---|----------|----------|----------|----------|----------|----------|----------|
| 0 | NUL 0 | DLE 16 | | 0 32 | @ 64 | P 80 | ' 96 | p 112 | | | - 128 | â 144 | Â 160 | Á 176 | ä 192 | å 208 | æ 224 |
| 1 | SOH 1 | DC1 17 | ! 33 | 1 49 | A 65 | Q 81 | a 97 | q 113 | | | À 129 | Ý 145 | ê 161 | î 177 | Ã 193 | þ 209 | ð 225 |
| 2 | STX 2 | DC2 18 | " 34 | 2 50 | B 66 | R 82 | b 98 | r 114 | | | Â 130 | ý 146 | ô 162 | ø 178 | ã 194 | .210 | · 226 |
| 3 | ETX 3 | DC3 19 | # 35 | 3 51 | C 67 | S 83 | c 99 | s 115 | | | È 131 | ° 147 | û 163 | Æ 179 | Ð 195 | µ 211 | μ 227 |
| 4 | EOT 4 | DC4 20 | \$ 36 | 4 52 | D 68 | T 84 | d 100 | t 116 | | | Ê 132 | Ç 148 | á 164 | â 180 | ð 196 | ¶ 212 | ¶ 228 |
| 5 | ENQ 5 | NAK 21 | % 37 | 5 53 | E 69 | U 85 | e 101 | u 117 | | | Ë 133 | ç 149 | é 165 | í 181 | Í 197 | ¾ 213 | ¾ 229 |
| 6 | ACK 6 | SYN 22 | & 38 | 6 54 | F 70 | V 86 | f 102 | v 118 | | | Î 134 | Ñ 150 | ó 166 | ø 182 | ì 198 | — 214 | — 230 |
| 7 | BEL 7 | ETB 23 | ' 39 | 7 55 | G 71 | W 87 | g 103 | w 119 | | | Ï 135 | ñ 151 | ú 167 | æ 183 | Ó 199 | ¼ 215 | ¼ 231 |
| 8 | BS 8 | CAN 24 | (40 | 8 56 | H 72 | X 88 | h 104 | x 120 | | | ÿ 136 | ï 152 | à 168 | Ä 184 | Ò 200 | ½ 216 | ½ 232 |
| 9 | HT 9 | EM 25 |) 41 | 9 57 | I 73 | Y 89 | i 105 | y 121 | | | ÿ 137 | ÿ 153 | è 169 | ì 185 | Û 201 | ¾ 217 | ¾ 233 |
| A | LF 10 | SUB 26 | * 42 | : 58 | J 74 | Z 90 | j 106 | z 122 | | | ˆ 138 | ˆ 154 | ð 170 | Ö 186 | õ 202 | ° 218 | ° 234 |
| B | VT 11 | ESC 27 | + 43 | ; 59 | K 75 | [91 | k 107 | { 123 | | | ˆ 139 | ˆ 155 | £ 171 | ù 187 | Û 203 | Š 219 | « 235 |
| C | FF 12 | FS 28 | , 44 | < 60 | L 76 | \ 92 | l 108 | 124 | | | ˆ 140 | ˆ 156 | ¥ 172 | ä 188 | É 204 | š 220 | ■ 236 |
| D | CR 13 | GS 29 | - 45 | = 61 | M 77 |] 93 | m 109 | } 125 | | | Û 141 | Û 157 | § 173 | ë 189 | Û 205 | » 221 | » 237 |
| E | SO 14 | RS 30 | . 46 | > 62 | N 78 | ^ 94 | n 110 | ~ 126 | | | Û 142 | Û 158 | f 174 | ö 190 | ß 206 | ÿ 222 | ± 238 |
| F | SI 15 | US 31 | / 47 | ? 63 | O 79 | _ 95 | o 111 | ☐ 127 | | | £ 143 | ¢ 159 | ü 175 | Û 191 | Û 207 | ÿ 223 | ÿ 239 |

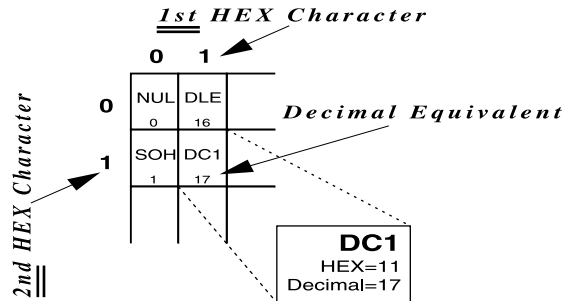

APPENDIX C

Code Page 437 Symbol Set

| | 0 | 1 | 2 | 3 | 4 | 5 | 6 | 7 | 8 | 9 | A | B | C | D | E | F |
|---|----------|----|----|----|----|----|-----|-----|-----|-----|-----|-----|-----|-----|-----|-----|
| 0 | NUL 0 | ▶ | | 0 | @ | P | ` | p | Ç | É | á | ☐ | ┌ | └ | α | ≡ |
| 1 | ☺ | ◀ | ! | 1 | A | Q | a | q | ü | æ | í | ☒ | ┌ | └ | β | ± |
| 2 | ☻ | ↕ | " | 2 | B | R | b | r | é | Æ | ó | ☒ | ┌ | └ | Γ | ≥ |
| 3 | ♥ | !! | # | 3 | C | S | c | s | â | ô | ú | ┌ | └ | ┌ | π | ≤ |
| 4 | ♦ | ¶ | \$ | 4 | D | T | d | t | ä | ö | ñ | ┌ | └ | ┌ | Σ | ∫ |
| 5 | ♣ | § | % | 5 | E | U | e | u | à | ò | Ñ | ┌ | └ | ┌ | σ | J |
| 6 | ♠ | — | & | 6 | F | V | f | v | â | û | ª | ┌ | └ | ┌ | μ | ÷ |
| 7 | ● | ↑ | ' | 7 | G | W | g | w | ç | ù | º | ┌ | └ | ┌ | τ | ≈ |
| 8 | ◼ | ↑ | (| 8 | H | X | h | x | ê | ÿ | ¿ | ┌ | └ | ┌ | Φ | ° |
| 9 | ○ | ↓ |) | 9 | I | Y | i | y | ë | Ö | ¬ | ┌ | └ | ┌ | θ | . |
| A | ◉ | → | * | : | J | Z | j | z | è | Ü | ¬ | ┌ | └ | ┌ | Ω | . |
| B | ♂ | ← | + | ; | K | [| k | { | ÿ | ç | ½ | ┌ | └ | ┌ | δ | √ |
| C | ♀ | ┌ | , | < | L | \ | l | l | î | £ | ¼ | ┌ | └ | ┌ | ∞ | n |
| D | 🎵 | ↔ | - | = | M |] | m | } | ì | ¥ | ï | ┌ | └ | ┌ | ∅ | ² |
| E | 🎵 | ▲ | . | > | N | ^ | n | ~ | Ä | Pt | « | ┌ | └ | ┌ | € | ■ |
| F | ☼ | ▼ | / | ? | O | _ | o | ⏏ | Å | f | » | ┌ | └ | ┌ | ☾ | |
| | 15 | 31 | 47 | 63 | 79 | 95 | 111 | 127 | 143 | 159 | 175 | 191 | 207 | 223 | 239 | 255 |

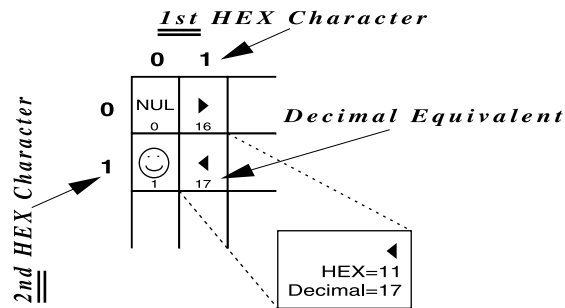

APPENDIX C

Latin 1 Euro Symbol Set

Includes US ASCII (dec. 1-127) and Windows 3.1 Latin 1 Extension Symbol Sets

| | 0 | 1 | 2 | 3 | 4 | 5 | 6 | 7 | 8 | 9 | A | B | C | D | E | F |
|---|----------|-----------|----------|---------|---------|---------|----------|----------|----------|----------|------------|----------|----------|----------|----------|----------|
| 0 | NUL 0 | DLE 16 | SP 32 | 0 48 | @ 64 | P 80 | ` 96 | p 112 | € 128 | | NBS 144 | ° 160 | À 176 | Ð 192 | à 208 | ð 224 |
| 1 | SOH 1 | DC1 17 | ! 33 | 1 49 | A 65 | Q 81 | a 97 | q 113 | | ‘ 129 | ı 145 | ± 161 | Á 177 | Ñ 193 | á 209 | ñ 225 |
| 2 | STX 2 | DC2 18 | " 34 | 2 50 | B 66 | R 82 | b 98 | r 114 | , | ’ 130 | ¢ 146 | ² 162 | Â 178 | Ò 194 | â 210 | ò 226 |
| 3 | ETX 3 | DC3 19 | # 35 | 3 51 | C 67 | S 83 | c 99 | s 115 | f 131 | “ 147 | £ 163 | ³ 179 | Ã 195 | Ó 211 | ã 227 | ó 243 |
| 4 | EOT 4 | DC4 20 | \$ 36 | 4 52 | D 68 | T 84 | d 100 | t 116 | „ 132 | ” 148 | ¤ 164 | ´ 180 | Ä 196 | Ô 212 | ä 228 | ô 244 |
| 5 | ENQ 5 | NAK 21 | % 37 | 5 53 | E 69 | U 85 | e 101 | u 117 | … 133 | • 149 | ¥ 165 | µ 181 | Å 197 | Õ 213 | å 229 | õ 245 |
| 6 | ACK 6 | SYN 22 | & 38 | 6 54 | F 70 | V 86 | f 102 | v 118 | ‡ 134 | - 150 | ı 166 | ¶ 182 | Æ 198 | Ö 214 | æ 230 | ö 246 |
| 7 | BEL 7 | ETB 23 | ' 39 | 7 55 | G 71 | W 87 | g 103 | w 119 | ‡ 135 | — 151 | § 167 | · 183 | Ç 199 | × 215 | ç 231 | ÷ 247 |
| 8 | BS 8 | CAN 24 | (40 | 8 56 | H 72 | X 88 | h 104 | x 120 | ^ 136 | ~ 152 | ˆ 168 | ˜ 184 | È 200 | Ø 216 | è 232 | ø 248 |
| 9 | HT 9 | EM 25 |) 41 | 9 57 | I 73 | Y 89 | i 105 | y 121 | ‰ 137 | ™ 153 | © 169 | ı 185 | É 201 | Ù 217 | é 233 | ù 249 |
| A | LF 10 | SUB 26 | * 42 | : | J 74 | Z 90 | j 106 | z 122 | Š 138 | š 154 | ª 170 | º 186 | Ê 202 | Ú 218 | ê 234 | ú 250 |
| B | VT 11 | ESC 27 | + 43 | ; 59 | K 75 | [91 | k 107 | { 123 | < 139 | > 155 | « 171 | » 187 | Ë 203 | Û 219 | ë 235 | û 251 |
| C | FF 12 | FS 28 | , 44 | < 60 | L 76 | \ 92 | 108 | 124 | Œ 140 | œ 156 | ¬ 172 | ¼ 188 | Ï 204 | Ü 220 | ï 236 | ü 252 |
| D | CR 13 | GS 29 | - 45 | = 61 | M 77 |] 93 | m 109 | } 125 | | | - 157 | ½ 173 | Í 189 | Ý 205 | í 221 | ý 237 |
| E | SO 14 | RS 30 | . 46 | > 62 | N 78 | ^ 94 | n 110 | ~ 126 | | | ® 158 | ¾ 174 | Î 190 | Þ 206 | î 222 | þ 238 |
| F | SI 15 | US 31 | / 47 | ? 63 | O 79 | _ 95 | o 111 | ☐ 127 | | ÿ 143 | — 159 | ¿ 175 | Ï 191 | ß 207 | ï 223 | ÿ 255 |

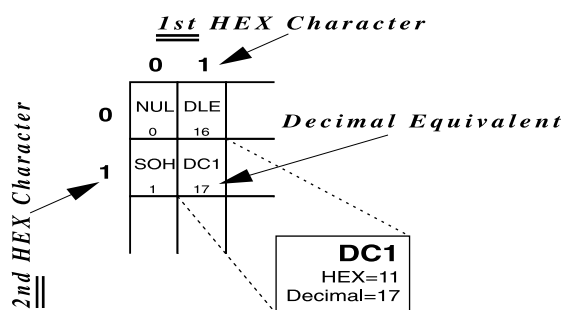

APPENDIX D

Serial Port Specifications

The I-O Print Box TxS plus uses a standard, RS-232-C, 25-pin serial printer cable for connection to a serial printer and for connection to a serial PC/LAN print server port.

The Print Box's input and output connectors use the same pin assignments. They are:

| | |
|--------|---|
| Shell: | Chassis Ground |
| 1: | Chassis Ground |
| 2: | Transmit (TXD)output |
| 3: | Receive (RXD)input |
| 4: | Request To Send (RTS)output |
| 5: | Clear To Send (CTS)input |
| 6: | Data Set Ready (DSR)input |
| 7: | Signal Ground |
| 8-19: | No connection |
| 20: | Data Terminal Ready (DTR)output |

The serial printer cable shipped with the I-O Print Box TxS has the following pin assignments:

| | |
|-------------------|-------|
| DB25F | DB25M |
| Shell | Shell |
| 2 | 3 |
| 3 | 2 |
| 5, 6, 8 | 20 |
| 7 | 7 |
| 20 | 5,6,8 |

This pin out will work with most PCs and printers (i.e. the supplied cable can be used as either sharing cable or printer cable). When used to connect the printer to the print box, the cable's female side (DB25F) is connected to the Print Box. When used as a sharing cable, the male end (DB25M) is connected to the Print Box.

APPENDIX D

This page left intentionally blank.

APPENDIX E**Parallel Port Specifications**

The I-O Print Box TxP plus and TxP lite use standard 36-pin/25-pin Centronics printer cables for connection to a parallel printer and to connect a parallel PC/LAN printer server port. (The Print Box TxP lite uses the connection to the PC/LAN for interface configuration only.)

The 25-pin connector on the Print Box label "Parallel Out To Printer" has the following pin assignments:

| Pin Number | Direction | Name |
|-------------------|------------------|-----------------------|
| 1 | Output | nStrobe |
| 2-9 | Output | Data 1 - Data 8 |
| 10 | Input | nAck |
| 11 | Input | Busy |
| 12 | Input | PError |
| 13 | Input | Select |
| 14 | Output | nAutoFd (always high) |
| 15 | Input | nFault |
| 16 | Output | nInit (always high) |
| 17 | Output | nSelectIn (held low) |
| 18-25 | | Signal Ground |
| Shell | | Chassis Ground |

APPENDIX E

The 36-pin connector on the Print Box labeled "Parallel In From PC/LAN" (TxP plus) and "Parallel Setup Port From PC/LAN" uses the following pin assignment:

| Pin Number | Direction | Name |
|------------|-----------|---|
| 1 | Input | nStrobe |
| 2-9 | Input | Data 1 - Data 8 |
| 10 | Output | nAck |
| 11 | Output | Busy |
| 12 | Output | PError |
| 13 | Output | Select |
| 14, 15 | | No connection |
| 16 | | Signal Ground |
| 17 | | Chassis Ground |
| 18 | Output | Optional +5V (350mA max) |
| 19-30 | | Signal Ground |
| 31 | Input | nSelectIn (an Acknowledge will be generated in response to this input going active, however, the interface will not be reset) |
| 32 | Input | nFault |
| 34-36 | | No connection |
| Shell | | Chassis Ground |

APPENDIX F

Transferring Power to Pin 18

To transfer power to pin 18 of the parallel input connector of the Print Box TxP plus, a jumper must be moved on the interface board. To move this jumper do the following:

1. Power off the printer, the Print Box, and the attached PC or LAN print server.
2. Disconnect all cables from the Print Box.
3. Remove the two black screws from the outside of the back panel.
4. Pull out the interface's back panel, together with the attached board.
5. Locate the jumper in the lower left corner, right above the parallel connector labeled "Parallel In From PC/LAN" (see Figure 1).
6. Remove the black jumper from the pin, then reinsert it covering both pins (see Figures 1a and 1b).

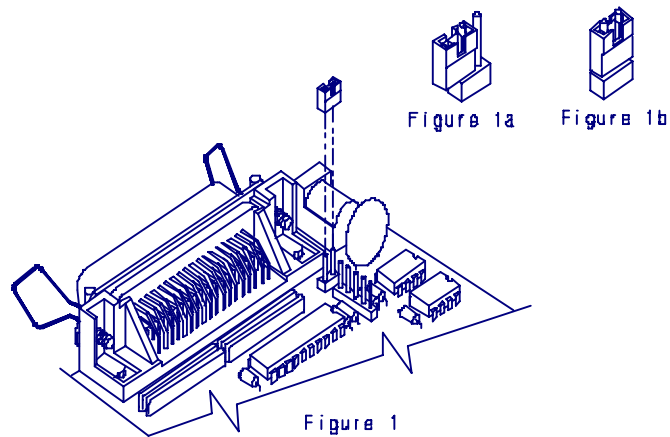

APPENDIX F

7. Slide the interface board back into the bottom groove of the chassis.
8. Tighten the black screws on the back panel.
9. Connect the printer and the PC/LAN to the Print Box, then connect the power cord.
10. Turn on the printer, then the I-O Print Box.

WARRANTY INFORMATION

Manufacturer's One Year Limited Warranty (United States)

The following warranty applies only to products purchased and operated within the United States.

I-O Corporation (I-O) warrants this product against defects in material and workmanship for a period of one year commencing from date of purchase by the original customer, when operated and maintained in accordance with I-O's published specifications. I-O's liability shall be limited, at its option and expense, to refund to buyer the actual amount paid by buyer or to repair or replace any defective or nonconforming product or part thereof, F.O.B. I-O's authorized repair depot. Buyer may obtain a replacement product by meeting the terms of the I-O Customer On-Site Exchange Repair Policy in effect at the time of the request.

THE EXPRESS WARRANTY SET FORTH ABOVE IS IN LIEU OF ALL OTHER EXPRESS OR IMPLIED WARRANTIES. OTHERWISE, THE PRODUCTS ARE SOLD AS IS WITHOUT FURTHER OBLIGATION OR LIABILITY ON THE PART OF I-O. I-O EXPRESSLY EXCLUDES ANY IMPLIED WARRANTIES OF MERCHANTABILITY AND FITNESS FOR A PARTICULAR PURPOSE.

EXCEPT AS EXPRESSLY SET FORTH HEREIN, IN NO EVENT SHALL I-O BE LIABLE FOR ANY CLAIMS OR DAMAGE ARISING DIRECTLY OR INDIRECTLY FROM THE FURNISHING OR FAILURE TO FURNISH PRODUCTS, SPARE OR REPLACEMENT PARTS, INFORMATION OR SERVICES HEREUNDER. UNDER NO CIRCUMSTANCES SHALL I-O BE LIABLE IN ANY WAY FOR INDIRECT, SPECIAL OR CONSEQUENTIAL DAMAGES, INCLUDING, BUT NOT LIMITED TO LOST BUSINESS OR PROFITS, WHETHER OR NOT FORESEEABLE AND WHETHER OR NOT BASED ON BREACH OF WARRANTY, CONTRACT, OR NEGLIGENCE.

Warranty

WARRANTY INFORMATION

This page left intentionally blank.

WARRANTY INFORMATION

Customer On-Site Exchange Repair Policy

Terms, Conditions, and Limitations

Effective May 1, 1994^a

For products covered by the I-O Corporation (I-O) Manufacturer's Limited Warranty (United States), I-O's Customer On-Site Exchange (COE) Repair Policy provides customers with a replacement unit for a defective product, subject to the following terms and conditions:

Call Customer Support

- If a product fails call I-O Customer Support for assistance at (801) 972-1446.

Verify Product Failure

- I-O will verify the product serial number, warranty coverage and product failure.
- * You are responsible for assisting in verifying the product failure.
- When I-O Customer Support verifies a product failure they will issue a Return Merchandise Authorization (RMA) number for the failed product.

Replacement Units

- Replacement units are shipped from I-O's stock of refurbished units, subject to availability.
- Replacement units carry the same warranty as remaining on the original product.
- I-O's COE Repair Policy applies only to warranted product failures. Buyer guarantees payment for non-warranted product repairs or replacement.

WARRANTY INFORMATION

Customer On-Site Exchange Repair Policy (Continued)

Return Your Failed Unit

- When you return the failed product it must be shipped freight prepaid. Always note the RMA number on the outside of the package.

Install the Replacement Unit

- You are responsible for installing the replacement unit.
- After receiving the replacement unit please call I-O Customer Support if any assistance is required.

^a I-O reserves the right to change the terms and conditions of this policy without notice.

WARRANTY INFORMATION

Manufacturer's One Year Limited Warranty (International)

The following warranty applies only to products purchased or operated outside the United States.

I-O Corporation (I-O) warrants this product against defects in material and workmanship for a period of one year commencing from date of purchase by the original customer, when operated and maintained in accordance with I-O's published specifications. I-O's liability shall be limited, at its option and expense, to refund to buyer the actual amount paid by buyer or to repair or replace any defective or nonconforming product or part thereof, F.O.B. I-O's authorized repair depot. Buyer may obtain warranty service by meeting the terms of the I-O Return-to-Depot Repair Policy in effect at the time of the request.

THE EXPRESS WARRANTY SET FORTH ABOVE IS IN LIEU OF ALL OTHER EXPRESS OR IMPLIED WARRANTIES. OTHERWISE, THE PRODUCTS ARE SOLD AS IS WITHOUT FURTHER OBLIGATION OR LIABILITY ON THE PART OF I-O. I-O EXPRESSLY EXCLUDES ANY IMPLIED WARRANTIES OF MERCHANTABILITY AND FITNESS FOR A PARTICULAR PURPOSE.

EXCEPT AS EXPRESSLY SET FORTH HEREIN, IN NO EVENT SHALL I-O BE LIABLE FOR ANY CLAIMS OR DAMAGE ARISING DIRECTLY OR INDIRECTLY FROM THE FURNISHING OR FAILURE TO FURNISH PRODUCTS, SPARE OR REPLACEMENT PARTS, INFORMATION OR SERVICES HEREUNDER. UNDER NO CIRCUMSTANCES SHALL I-O BE LIABLE IN ANY WAY FOR INDIRECT, SPECIAL OR CONSEQUENTIAL DAMAGES, INCLUDING, BUT NOT LIMITED TO LOST BUSINESS OR PROFITS, WHETHER OR NOT FORESEEABLE AND WHETHER OR NOT BASED ON BREACH OF WARRANTY, CONTRACT, OR NEGLIGENCE.

WARRANTY INFORMATION

This page left intentionally blank.

WARRANTY INFORMATION

Return-to-Depot Repair Policy

Terms, Conditions, and Limitations

Effective May 1, 1994^a

For products covered by the I-O Corporation (I-O) Manufacturer's Limited Warranty (International), I-O's Return-to-Depot (RTD) Repair Policy provides customers with warranty service for a defective product, subject to the following terms and conditions:

Call Customer Support

- If a product fails call I-O Customer Support for assistance at:

(801) 972-1446 for all locations outside the United States.

Verify Product Failure

- I-O will verify the product serial number, warranty coverage and product failure.
- You are responsible for assisting in verifying the product failure
- When I-O Customer Support verifies a product failure they will issue a Return Merchandise Authorization (RMA) number to authorize return of the failed product.

Select Your Preferred Repair Location

- I-O's Customer Support Representative will assist you in identifying the nearest I-O authorized repair depot.
- I-O's Customer Support Representative will provide you with an RMA transmittal form referencing the assigned RMA number and the authorized repair depot address.

WARRANTY INFORMATION

Return-to-Depot Repair Policy

(Continued)

Return Your Failed Unit

- Return the failed product to the I-O authorized repair depot previously identified, enclosing the RMA transmittal form. When you return the failed product it must be shipped freight prepaid.
- I-O's RTD Repair Policy applies only to warranted product failures. Buyer guarantees payment for non-warranted product repairs.

Install Your Repaired Unit

- I-O's authorized repair depot will service the faulty unit and return it to you, freight prepaid.
- You are responsible for installing the returned unit.
- After receiving the repaired unit please call I-O Customer Support if any assistance is required.

^a I-O reserves the right to change the terms and conditions of this policy without notice.

WARRANTY INFORMATION

Manufacturer's One Year Limited Warranty (European Area)

The following warranty applies only to products purchased and operated within the European Area.

I-O Corporation (I-O) warrants this product against defects in material and workmanship for a period of one year commencing from date of purchase by the original end-user, when operated and maintained in accordance with I-O's published specifications. I-O's liability shall be limited, at its option and expense, to refund to original end-user the actual amount paid by original end-user or to repair or replace any defective or nonconforming product or part thereof, F.O.B. I-O's authorized repair depot. Original end-user may obtain a replacement product by meeting the terms of the I-O Customer On-Site Exchange Repair Policy in effect at the time of the request.

THE EXPRESS WARRANTY SET FORTH ABOVE IS IN LIEU OF ALL OTHER EXPRESS OR IMPLIED WARRANTIES. OTHERWISE, THE PRODUCTS ARE SOLD AS IS WITHOUT FURTHER OBLIGATION OR LIABILITY ON THE PART OF I-O. I-O EXPRESSLY EXCLUDES ANY IMPLIED WARRANTIES OF MERCHANTABILITY AND FITNESS FOR A PARTICULAR PURPOSE.

EXCEPT AS EXPRESSLY SET FORTH HEREIN, IN NO EVENT SHALL I-O BE LIABLE FOR ANY CLAIMS OR DAMAGE ARISING DIRECTLY OR INDIRECTLY FROM THE FURNISHING OR FAILURE TO FURNISH PRODUCTS, SPARE OR REPLACEMENT PARTS, INFORMATION OR SERVICES HEREUNDER. UNDER NO CIRCUMSTANCES SHALL I-O BE LIABLE IN ANY WAY FOR INDIRECT, SPECIAL OR CONSEQUENTIAL DAMAGES, INCLUDING, BUT NOT LIMITED TO LOST BUSINESS OR PROFITS, WHETHER OR NOT FORESEEABLE AND WHETHER OR NOT BASED ON BREACH OF WARRANTY, CONTRACT, OR NEGLIGENCE.

WARRANTY INFORMATION

This page left intentionally

WARRANTY INFORMATION

Customer On-Site Exchange Repair Policy

Terms, Conditions, and Limitations

Effective June 1, 1997^a

For products covered by the I-O Corporation (I-O) Manufacturer's Limited Warranty (European Area), I-O's Customer On-Site Exchange (COE) Repair Policy provides original end-users with a replacement unit for a defective product, subject to the following terms and conditions:

Call Customer Support

- If a product fails call I-O Customer Support for assistance at 44(0) 1908 567722.

Verify Product Failure

- I-O will verify the product serial number, warranty coverage and product failure.
- You are responsible for assisting in verifying the product failure.
- When I-O Customer Support verifies a product failure they will issue a Return Merchandise Authorization (RMA) number for the failed product.

I-O Ships Replacement Unit

- Replacement units are shipped from I-O's stock of refurbished units, subject to availability.
- I-O will invoice you for full retail value of the replacement unit upon shipment from I-O.
- Replacement units carry the same warranty as remaining on the original product.
- I-O's COE Repair Policy applies only to warranted product failures. You must pay for non-warranted product repairs or replacement.

WARRANTY INFORMATION

Customer On-Site Exchange Repair Policy

(Continued)

Return Your Failed Unit

- When you return the failed product it must be shipped freight prepaid. To insure proper tracking always note the RMA number on the outside of the package.
- I-O will issue you a credit (reversing the replacement unit invoice amount) when the failed product is received by I-O.
- If you do not return the failed product (or pay the replacement unit invoice) within 14 calendar days of the date the replacement unit is shipped from I-O, your warranty coverage and service will be suspended on all I-O products you own.

Install the Replacement Unit

- You are responsible for installing the replacement unit.
- After receiving the replacement unit please call I-O Customer Support if any assistance is required.

^a I-O reserves the right to change the terms and conditions of this policy without notice.

DECLARATION OF CONFORMITY

EUROPEAN COMMUNITY COMPLIANCE STATEMENT:

This product is in conformity with the protection requirements of EC Council Directives 72/23/EEC, and 89/336/EEC on the approximation of the laws of the Member States relating to: Standard EN60950 (Safety of Information Technology Equipment); Standard EN50082-1 (Generic Immunity Standard for Residential, Commercial, and Light Industrial Products); and Standard EN55022 (Limits and Methods of Measurement of Radio Interference from Information Technology Equipment).

WARNING: This is a Class A product. In a domestic environment this product may cause radio interference in which case the user may be required to take adequate measures.

DECLARATION OF CONFORMITY

This page left intentionally blank.