



TC5000
Thin Client User's Guide

Copyright and Trademark Notices

Copyright 2005 I-O Corporation

ALL RIGHTS RESERVED

Information in this document is subject to change without notice and does not represent a commitment on the part of the manufacturer. No part of this guide may be reproduced or transmitted in any form or means and for any purpose, without the express written permission of the manufacturer.

I-O® is a registered trademark of I-O Corporation.

Citrix, WinFrame and ICA are registered trademarks of Citrix Systems, Inc. MetaFrame, Program Neighborhood and SpeedScreen are trademarks of Citrix Systems, Inc.

Windows CE, Windows NT, Windows 2000, Windows XP and RDP are trademarks or registered trademarks of Microsoft Corporation.

All other trademarks and registered trademarks are property of their respective owners.

Every effort has been made to make this guide as complete and accurate as possible, but no warranty of fitness is implied. The authors and the publisher shall have neither responsibility nor liability to any person or entity with respect to loss or damages arising from the use of information contained in this guide.

Document Number: WBT200-OMAN01-221

February 2005

I-O Corporation
1490 North 2200 West, Suite 100
Salt Lake City, UT 84116
801-973-6767
801-974-5683 fax
www.iocorp.com

Table of Contents

Introduction.....	6
About The I-O Thin Client	6
About this Guide.....	6
Related Information.....	7
Install the Thin Client	8
Step One: Unpack.....	8
Step Two: Prepare	8
Step Three: Connect accessories and power	9
Step Four: Connect to the Server	11
Step Five: Start the Thin client.....	11
Status of LEDs on the Front and Rear Panels.....	11
Shutting Down the Thin client	12
Setup the Thin Client.....	13
Step One: Start the Setup Wizard.....	13
Step Two: Terminal Name & Network Properties	14
IP Address.....	14
Name Servers	15
Step Three: Desktop Settings	15
Desktop Area and Refresh Frequency.....	16
Colors	17
Screen Saver	17
Step Four: Additional Settings in the Control Panel.....	18
122-Key Keyboard Support.....	18
Date and Time.....	19
Step Five: Finish.....	19
Creating Connections	20
Overview of the Terminal Connection Manager.....	20
Connections Tab.....	21
Configure Tab	22
Creating Connections.....	22
Specifying AutoStart / Default Connection.....	23
Editing a Connection	23
Deleting a Connection.....	24
Starting a Connection.....	24
Switching Connections.....	24
Closing a Connection	24

I-O 5250 Printing	25
Configure the AS/400, iSeries or eServer i5 for TN5250e.....	26
Create the I-O 5250 Printer Connection	27
Terminal Emulation	31
RDP	36
ICA	39
Microsoft Viewers	42
Internet Explorer.....	43
E-Mail Client.....	44
Using Connections	50
I-O 5250 Printing	50
Start the I-O 5250 Printer Session	50
Test the Printer Attached to the Thin Client.....	51
Eject a Page from the Printer	52
Cancel the Print Job.....	52
End the I-O 5250 Printer Session	52
I-O 5250 Printer Control Panel Options	52
Terminal Emulation	53
RDP Connection to Windows Terminal Servers	54
ICA Connection to Citrix Servers	55
Microsoft Viewers	56
Running the Viewer.....	56
Printing from a Viewer.....	57
Limitations of the Microsoft Viewers	58
TC5000 Printing Overview	59
Windows Media Player.....	60
E-mail	62
Configuring the E-mail Client	62
E-Mail Overview	68
Receiving Messages.....	73
Reading Messages	75
Composing and Editing Messages	81
Organizing Messages	84
Advanced Configuration	86
I-O Configuration Utility	86
Save a Configuration.....	87
Send a Configuration to a Thin Client.....	88
General Tab	91
Display Tab	92

Desktop Area and Refresh Frequency.....	92
Colors	93
Screen Saver	93
Control Panel.....	94
Internet Options.....	94
RDP Printers	96
Keyboard.....	97
System	98
Mouse	100
Volume and Sounds.....	101
Certificates	102
Regional Settings	103
Network and Dialup Connections.....	105
LPR/LPD	117
SNMP Setup	118
ICA Global Settings.....	119
122-Keyboard.....	120
USB Storage	121
Troubleshooting	122
Firmware Upgrade Process	130
I-O Configuration Utility Upgrade Process	133
Uninstalling the I-O Configuration Utility	134
Saving / Restoring the Thin Client's Configuration	135
Saving a Configuration.....	135
Restoring a Configuration	136
Restoring Factory Defaults.....	138
Boot Up Process	138
General Tab Process	138
Accessing the Motherboard's Startup Processes	140
Microsoft Software License	141
Manufacturer's Warranty & Repair Policy	145
FCC & European Compliance.....	149

Introduction

About The I-O Thin Client

The I-O Thin Client is a robust solution available for thin client computing in the IBM, Windows, Citrix and UNIX environments.

Equipped with Microsoft's Windows CE.NET operating system, the product provides seamless connectivity to Windows NT 4.0 TSE, Windows 2000, Windows XP, Windows 2003 and Citrix servers using Microsoft's RDP and Citrix's ICA protocols. Using I-O Corporation's award winning display and printer emulations, complete access is provided for AS/400, iSeries and eServer i5 host environments. The terminal emulation suite for UNIX connectivity.

Microsoft's Internet Explorer V6 for CE browser is built into the thin client to provide instant access to the Internet.

The thin client also includes Microsoft's Media Player and viewers for Word, Excel, PowerPoint as well as a PDF viewer. An e-mail thin client is also included.

The user-friendly software interface allows the system administrator to easily and quickly configure the thin client. The I-O Configuration Utility allows the system administrator to remotely configure and update the thin client.

The term client is used in this guide to represent the I-O Thin Client.

Consistent with our policy of continuous development, the product you received may have features in addition to those described in this guide. Please visit us at www.iocorp.com for current information.

About this Guide

This guide is intended to assist the network administrator of your organization to setup and configure the software of the thin client.

The following symbols are used in the guide.



Caution: This symbol highlights procedures that, if not correctly performed or adhered to, could damage or corrupt the product or adversely affect the security and functionality of the product. Do not proceed beyond such points until the required conditions are fully understood and achieved.



Note: This symbol denotes useful additional information that is relevant to the procedure or feature being described.



Tip: This symbol denotes a hint, shortcut or alternate method to aid or supplement the procedure being described.

The guide contains screenshots of relevant dialog boxes and windows for your reference. The sizes of screenshots are not representative of the actual sizes of the dialog boxes and windows on your screen.

Related Information

Besides this guide, the following other documents contain information relevant to the thin client. These documents are available in PDF format on the CD that was provided with the product. . They may also be accessed from the Configuration Utility's Help menu.

- ***TN5250e Printer Emulation User's Guide***

This document provides detailed information about I-O Corporation's TN5250e printer emulation.

- ***I-O Configuration Utility Help***

This document is available from the Help menu when the Configuration Utility is running.

- ***Terminal Emulation User's Guide***

This document provides detailed information about the TeemTalk terminal emulation suite included in the thin client.

- ***Client for Windows CE Windows-Based Terminals Administrator's Guide***

This document provides the administrator with detailed information about configuring the ICA client.

Other resources that may be needed to fully utilize the features and capabilities of the thin client include:

- ***Network Administrator***

This individual's assistance will be helpful for IP address assignment, general network issues, etc.

- ***Microsoft Certified System Engineer***

This individual's assistance will be helpful for creating, configuring and utilizing Microsoft's Terminal Server capabilities.

- ***Citrix Certified Administrator***

This individual's assistance will be required for creating, configuring and utilizing Citrix server connections.

Install the Thin Client

This chapter describes the procedure to install the product hardware.

Step One: Unpack

The carton in which the product was shipped to you contains the following:

- TC5000 Series Thin client
- Stand
- External Power Supply
- Mouse
- 104 or 122-Key keyboard
- CD containing the I-O Configuration Utility and User's Guides
- Getting Started Guide

When you open the carton, if you find any discrepancy between the contents of the carton and the above list, contact the dealer or reseller from whom you purchased the product immediately.



NOTE: PLEASE RETAIN THE ORIGINAL CARTON AND PACKING MATERIAL. THEY WOULD BE REQUIRED TO AVOID DAMAGE DURING TRANSIT.

Step Two: Prepare

1. The site where you want to install the product must have the following
 - Two 100~120V AC, 2A, 50Hz, 3-pin power outlets (*one each for the thin client and the display unit*).



NOTE: ENSURE THAT THE POWER OUTLET IS PROPERLY REGULATED AND GROUNDED. A FLOATING GROUND / CHASSIS COULD CAUSE AN ELECTRIC SHOCK.

- Well ventilated, clean, dry and dust free atmosphere
 - Specified environmental conditions
 - Table or desk of suitable size.
2. Place the thin client in the upright or vertical position on the desk or table in a location that provides easy access to the power switch on the front panel.
 3. Ensure a minimum space of 2 inches (5cm) on all sides of the unit for efficient convection cooling.



CAUTION: BE CERTAIN THE VENTS ON THE TOP AND BOTTOM OF THE UNIT ARE NOT BLOCKED!

Step Three: Connect accessories and power



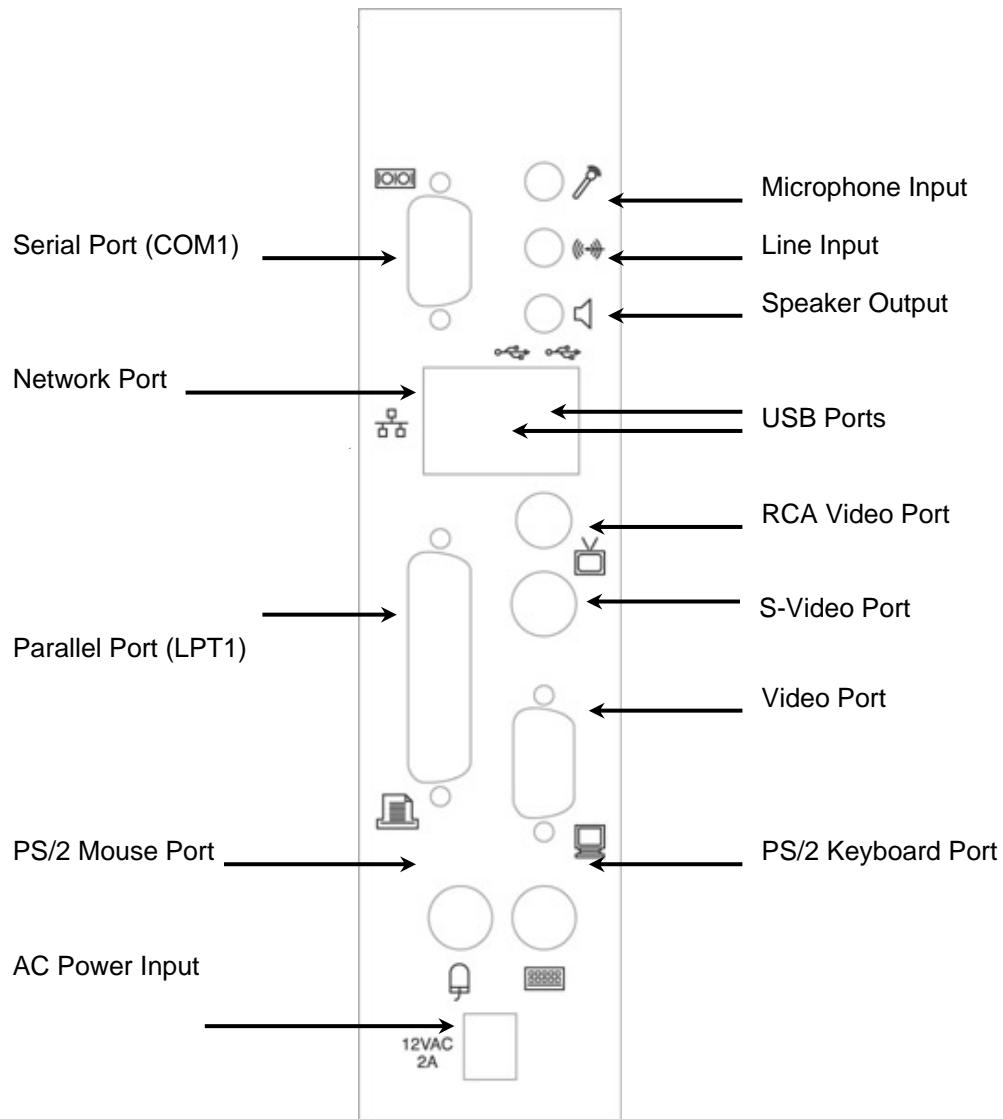





The connectors for devices supported by the product are located on the rear panel.



See the following page for details about the connectors and cables and the order for connecting them.



CAUTION: BEFORE CONNECTING ANY CABLE, ENSURE THAT THE EXTERNAL POWER SUPPLY IS NOT CONNECTED TO THE WALL OUTLET. THE POWER MUST BE CONNECTED ONLY **AFTER** ALL OTHER CONNECTIONS ARE MADE.

Follow the instructions below to connect various accessories	Connector Symbol
✓ Connect the mouse to the PS/2 Mouse port	
✓ Connect the keyboard to the PS/2 Keyboard port	
✓ (Optional) Connect the printer to the parallel port	
✓ Connect the video cable from the CRT or LCD display unit to the DB-15 video port	
✓ Connect the network cable to the 10/100 Base-T Ethernet port	
✓ (Optional) Connect USB devices to the USB 1.1 ports	
✓ (Optional) Connect external speakers to the speaker port	
✓ (Optional) Connect serial devices (i.e. modem) to the COM ports	
✓ (Optional) Connect either a composite or SVGA TV cable. When the TV display output is selected, the screen will be shown on both the display and on the TV with one exception – LCD monitors cannot support the TV output option.	
✓ Connect the output of the AC Transformer to the power inlet	12VAC 2A



CAUTION: ENSURE THAT THE SCREWS PROVIDED WITH D-TYPE CONNECTORS (LPT1, COM1 AND VIDEO PORTS) ARE FASTENED.



CAUTION: DO NOT USE A LCD MONITOR AND A TV TOGETHER. THE FREQUENCY REQUIRED FOR A TV SIGNAL MAY DAMAGE THE LCD MONITOR.



NOTE: OTHER OPTIONAL ACCESSORIES (SPEAKER OR MICROPHONE) SHOULD ALSO BE CONNECTED AT THIS TIME, AND PRIOR TO POWERING UP THE THIN CLIENT. IF THEY ARE ATTACHED AT A LATER TIME, MAKE CERTAIN THAT THE POWER CONNECTOR IS DISCONNECTED WHILE ATTACHING THE ACCESSORIES.

Step Four: Connect to the Server

Connect a 10/100Base-T cable from the network outlet of the thin client to a hub.



NOTE: BEFORE CONNECTING ANY CABLE, ENSURE THAT EXTERNAL POWER SUPPLY IS DISCONNECTED AND THAT NO POWER IS BEING SUPPLIED TO THE THIN CLIENT.

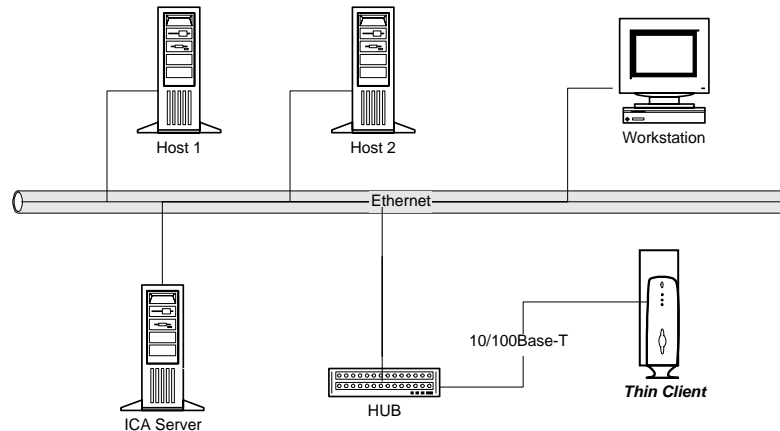

Step Five: Start the Thin client

To start the thin client, connect the external power supply to the wall outlet and press the On/Off switch located on the front panel. Refer to the Setup the Thin Client section for instructions to setup the thin client software.



NOTE: WHEN THERE IS A POWER INTERRUPTION TO THE EXTERNAL POWER SUPPLY, YOU MUST PRESS THE ON/OFF SWITCH ON THE FRONT PANEL TO START THE UNIT. THE THIN CLIENT WILL NOT AUTOMATICALLY RESTART WHEN THE SUPPLY OF POWER RESUMES.

Status of LEDs on the Front and Rear Panels

The front panel of the thin client has two LEDs on the right and left side of the On/Off switch.

- The Power-LED on the left side glows green when the unit is switched on and remains on until the unit is switched off.
- The Internal Storage Access LED on the right side flickers red when the thin client is accessing the thin client's firmware or locally stored applications such as Internet Explorer.

The rear panel of the thin client has two LEDs next to the Network connector.

- The green LED flashes when the thin client communicates at 100 Mbps and blinks slowly when communicating at 10 Mbps.
- The yellow LED turns on only when the thin client communicates at 10 Mbps.



NOTE: THE THIN CLIENT, LIKE THE CURRENT PCs, ALWAYS HAS POWER APPLIED TO THE MOTHERBOARD AS LONG AS THE POWER TRANSFORMER IS CONNECTED. IN THE STAND BY CONDITION (POWER LED ON THE FRONT IS OFF, BUT THE GREEN ETHERNET LED WILL BE ON), THE THIN CLIENT ONLY USES 1 WATT OF POWER (WHEN ON AND RUNNING, THE THIN CLIENT USES 20 WATTS).

Shutting Down the Thin client

There are two methods for shutting down the thin client.

- The fastest method is to click the Shutdown button on the Terminal Connection Manager screen. Click Yes to confirm the unit is to be shut down.
- Press and hold the On/Off switch on the front panel for about 20 seconds.

The Power LED will stop glowing.



NOTE: EVEN IF THE THIN CLIENT IS SWITCHED OFF (USING THE POWER SWITCH ON THE FRONT PANEL), A STANDBY SUPPLY OF POWER IS BEING PROVIDED TO THE MOTHERBOARD. TO COMPLETELY SWITCH OFF POWER SUPPLY TO THE UNIT, THE EXTERNAL POWER SUPPLY HAS TO BE DISCONNECTED.



CAUTION: BE CERTAIN TO EXIT ALL ACTIVE CONNECTIONS PRIOR TO SHUTTING DOWN THE THIN CLIENT.

Setup the Thin Client

This chapter describes the procedure to setup the software of the thin client. This procedure must be performed by the system administrator. It is assumed the thin client has been installed properly using the instructions in the previous section.

Step One: Start the Setup Wizard

When you switch the thin client on for the first time or if the thin client has been reset to factory defaults, a Setup Wizard is automatically started. The wizard will guide you through the process of configuring the thin client.



NOTE: THE SETUP WIZARD IS STARTED AUTOMATICALLY UNDER THE FOLLOWING CIRCUMSTANCES:

- WHEN YOU SWITCH THE THIN CLIENT ON FOR THE FIRST TIME.
- WHEN YOU RESTORE DEFAULT SETTINGS OF THE THIN CLIENT THROUGH THE GENERAL TAB OF THE TERMINAL PROPERTIES DIALOG-BOX.

The Setup Wizard has several dialog boxes that display in succession. Some dialog boxes provide information, while others require input. Every dialog-box contains buttons to take you backward or forward through the setup process, and to confirm or cancel input and selections.

The first dialog box of the Setup Wizard is shown below. Click **Next>** to continue.

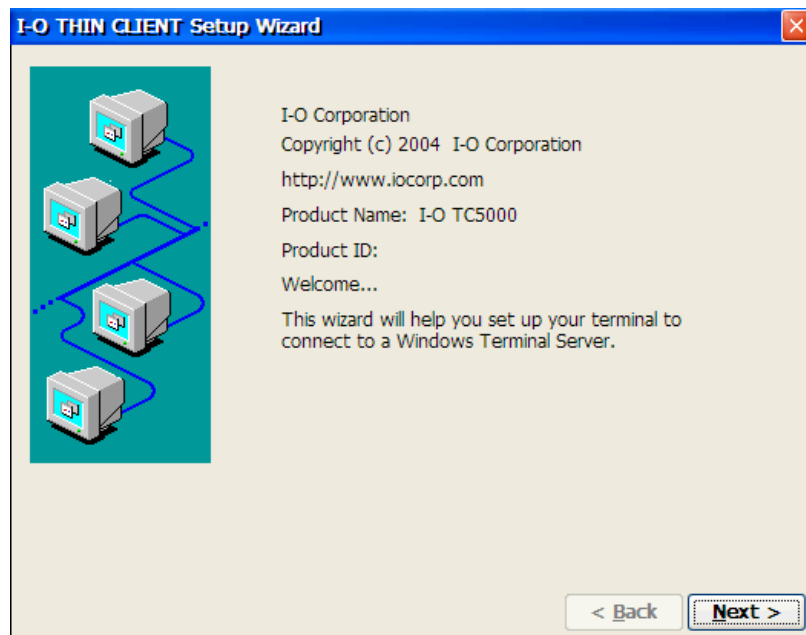

Step Two: Terminal Name & Network Properties

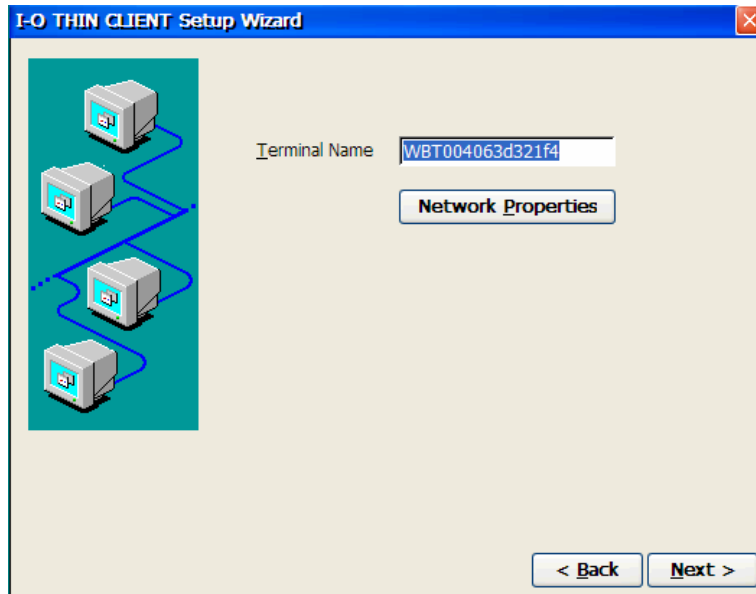

The above dialog box contains the field where you will enter the name this thin client will be identified as to the network. You may either accept the default name (which is based upon the MAC address of the network interface component of the thin client), or enter a name of your choice.



NOTE: THE NAME MAY BE UP TO 15 CHARACTERS IN LENGTHS, AND MUST BEGIN WITH AN ALPHA CHARACTER.

You will next need to setup up the IP address of the thin client. This can either be done automatically by DHCP, or you will need to manually enter a static IP address.

- If the IP address is assigned automatically by DHCP, click the **Next>** button on this screen and skip to Display Settings section below.
- If the IP address is to be a static address (one that does not change), click the **Network Properties** button to access the IP address setting screens.



TIP: TO IMPLEMENT LPD PRINTING IT IS RECOMMENDED THAT YOU SPECIFY A **STATIC IP ADDRESS** FOR THE THIN CLIENT. THIS IS NECESSARY BECAUSE, ON THE SERVER-SIDE YOU MUST SPECIFY THE IP ADDRESS OF THE THIN CLIENT. IF YOU MUST USE DHCP, THEN IT IS PREFERABLE THAT YOU RESERVE AN IP ADDRESS ON THE DHCP SERVER, FOR THE THIN CLIENT THAT YOU PLAN TO CONFIGURE AS THE LPD SERVER.

IP Address



NOTE: IF THE IP ADDRESS IS TO BE SET BY DHCP, SKIP THIS STEP AS THE THIN CLIENT DEFAULTS TO DHCP FOR ADDRESSING.

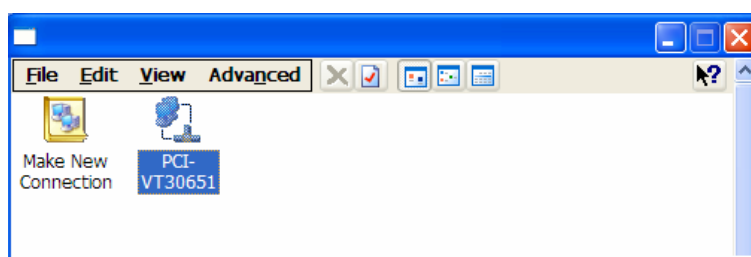

Right click on the **PCI-VT30651** icon and select Properties.

'PCI\VT30651' Settings [OK] [X]

IP Address | Name Servers

An IP address can be automatically assigned to this computer. If your network does not automatically assign IP addresses, ask your network administrator for an address, and then type it in the space provided.

Obtain an IP address via DHCP
 Specify an IP address

IP Address: [. . .]
 Subnet Mask: [. . .]
 Default Gateway: [. . .]

Select the **IP Address** tab.

'PCI\VT30651' Settings [OK] [X]

IP Address | Name Servers

An IP address can be automatically assigned to this computer. If your network does not automatically assign IP addresses, ask your network administrator for an address, and then type it in the space provided.

Obtain an IP address via DHCP
 Specify an IP address

IP Address: [. . .]
 Subnet Mask: [. . .]
 Default Gateway: [. . .]

Select **Specify an IP address**. Then manually enter the IP Address, the subnet mask and default gateway.

If there are DNS or WINS servers in the network, select the Name Servers tab. Otherwise, click the **OK** button on the title line of this screen, then click the close button (the **X** in the upper right corner). Click **Next>** to continue.

Name Servers

If there are DNS or WINS servers in the network, select the Name Servers tab.

'PCI\VT30651' Settings [OK] [X]

IP Address | Name Servers

Name server addresses may be automatically assigned if DHCP is enabled on this adapter. You can specify additional WINS or DNS resolvers in the space provided.

Primary DNS: [. . .]
 Secondary DNS: [. . .]
 Primary WINS: [. . .]
 Secondary WINS: [. . .]

Fill in the appropriate IP address for each server.

Click the **OK** button on the title line of this screen, then click the close button (the **X** in the upper right corner). Click **Next>** to continue.

Step Three: Desktop Settings

You will configure the monitor resolution, color pallet and screen saver settings on this screen.

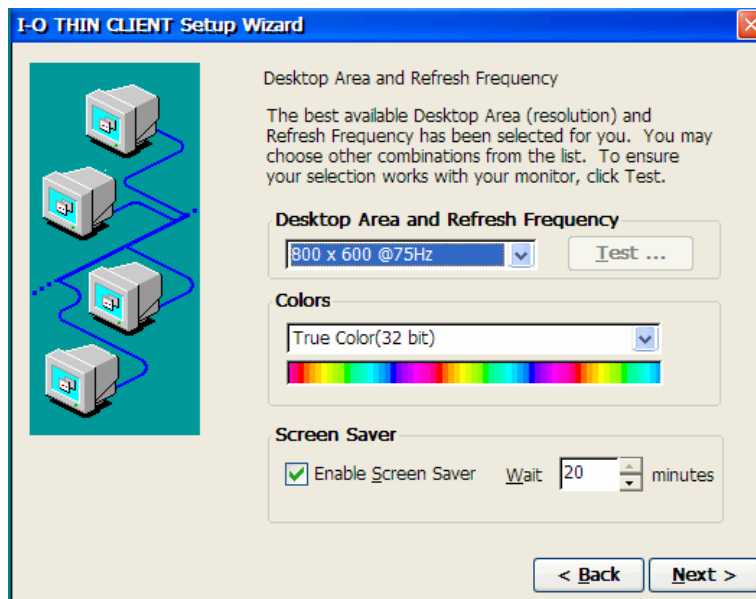

Desktop Area and Refresh Frequency

By default, the thin client is configured to display at a resolution of 800 x 600 and a refresh frequency of 75Hz.

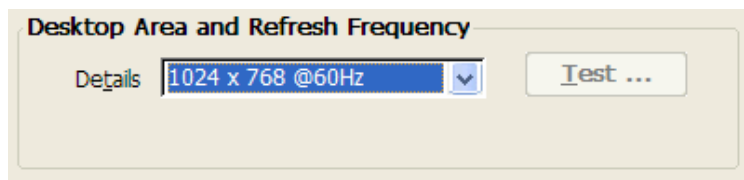

Select the resolution and refresh rate appropriate for your monitor.



NOTE: IN GENERAL CRT MONITORS CAN HANDLE A RANGE OF RESOLUTIONS AND REFRESH RATES. HOWEVER, LCD MONITORS PREFER THE RESOLUTION AND REFRESH RATE TO BE SET TO MATCH THEIR “NATIVE” RESOLUTION. GENERALLY THIS IS 1024 X 728 @ 60 HZ FOR 15” LCD MONITORS, AND 1280 X 1024 @ 60 HZ FOR 17” LCD MONITORS

If you select a resolution or refresh frequency other than the default setting, verify whether your monitor supports the selected setting by clicking the Test button.

The following prompt is displayed.

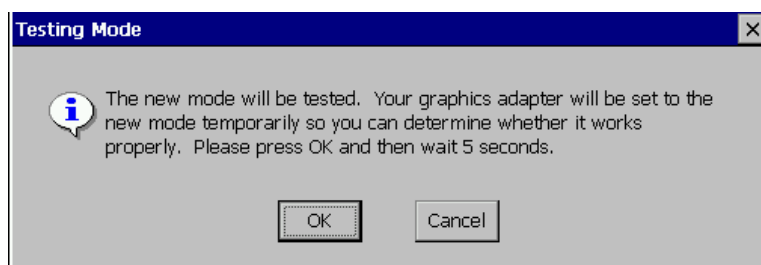

Click **OK** to continue. A test pattern of black and white boxes will be displayed for about five seconds.



NOTE: MONITORS WITH ON SCREEN DISPLAY (OSD) FEATURE MAY DISPLAY APPROPRIATE MESSAGES (SUCH AS ‘OUT OF SYNC’ OR ‘OUT OF RANGE’) IF THE SELECTED RESOLUTION AND FREQUENCY ARE NOT SUPPORTED. THE EXACT TEXT OF THE OSD MESSAGE WOULD DEPEND ON THE MODEL OF THE MONITOR CONNECTED TO THE THIN CLIENT.

The screen then clear and a following message box will be displayed.

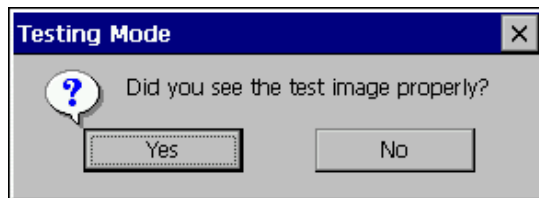

- If the appropriate test pattern was displayed, click **Yes** to return to the setup wizard.
- If the test pattern was not properly displayed, click **No**. The following message is displayed.



Click **OK** to change the setting and repeat the test.



CAUTION: USE THE **TEST** BUTTON TO TEST THE SELECTED RESOLUTION OF THE MONITOR. *FAILURE TO DO SO WILL RESULT IN THE THIN CLIENT NOT BEING ABLE TO DISPLAY THE SCREEN.*

IF YOU HAVE SELECTED AN UNSUPPORTED SETTING AND THE MONITOR DOES NOT DISPLAY THE SCREEN, YOU WILL NEED TO RESTART THE THIN CLIENT. SHUT DOWN THE THIN CLIENT BY HOLDING IN THE POWER BUTTON FOR SEVERAL SECONDS UNTIL THE POWER LED GOES OUT. PRESS THE POWER BUTTON TO POWER UP THE THIN CLIENT. IMMEDIATELY AFTER THE I-O SPLASH SCREEN CLEARS, PRESS THE **F7** KEY SEVERAL TIMES. AFTER A FEW SECONDS THE THIN CLIENT'S SETTINGS WILL BE RESTORED TO THE FACTORY DEFAULTS AND THE **SETUP WIZARD** WILL START.

Colors

Select the color pallet that your monitor supports from the Colors drop down box

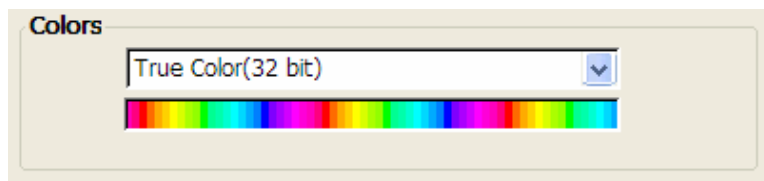

Screen Saver

Enable the screen saver, if desired, by checking the Enable Screen Saver box. Select the time to wait before the screen activates from the scroll box.

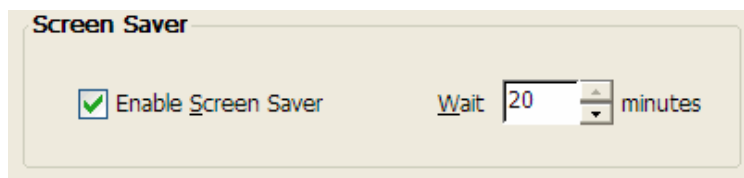

Click Next to proceed.

Step Four: Additional Settings in the Control Panel

The startup wizard will next present the Windows Control Panel.

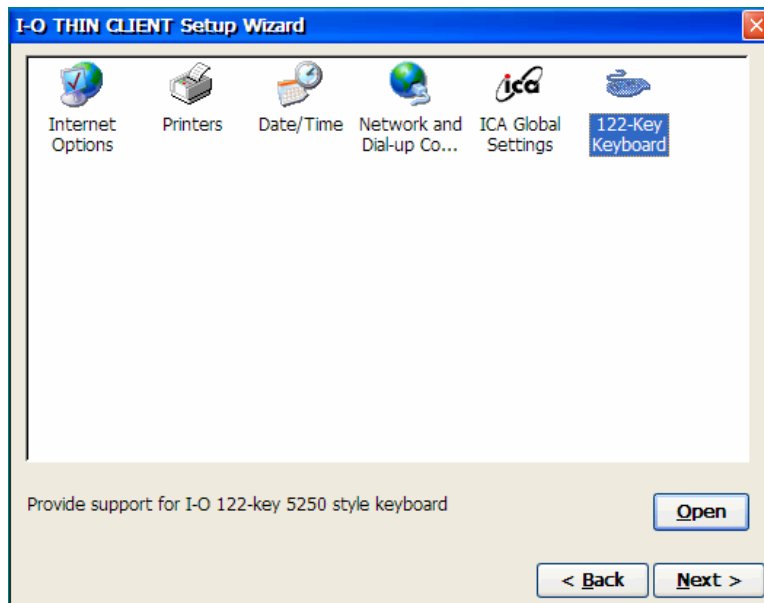

From this screen, any number of thin client properties may be configured. At a minimum, it is suggested that the following items be configured:

- 122-Key Keyboard Support
- Date and Time

After these items have been configured, click the **Next** button for the wizard to continue.

122-Key Keyboard Support

If an I-O 122-key 5250 Thin Client Keyboard is attached, select the 122-Key Keyboard icon. When the I-O 122-key 5250 Thin Client Keyboard is attached and this option is enabled, users can switch back and forth between IBM 5250 display sessions and Windows sessions with full keyboard functionality available in both environments.



Click on the check box to enable this option. Click **OK**.



TIP:: ON THE I-O 122-KEY 5250 THIN CLIENT KEYBOARD, 5250 FUNCTIONS ARE PRINTED ON THE KEY CAPS IN BLACK. WHERE WINDOWS FUNCTIONS DIFFER, THEY ARE PRINTED IN BLUE.

Date and Time

The thin client is equipped with a real time clock.

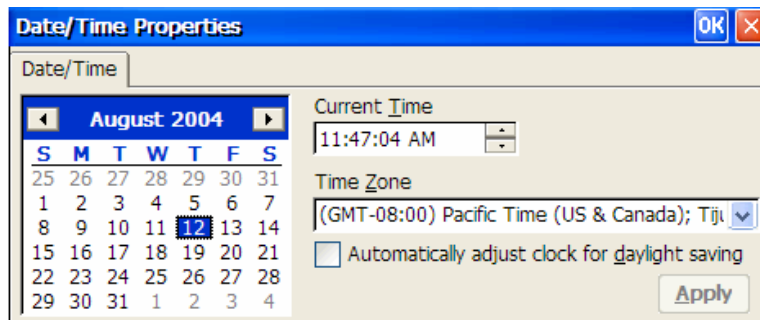

Select the date from the calendar. Set the current time in the scroll box. Select the time zone from the drop down box. Check the box for automatic adjustment for daylight savings time. Click **Apply** and then **OK**.

After these items have been configured, click the **Next** button for the wizard to continue.

Step Five: Finish



The above dialog-box marks the end of the Setup Wizard. Click **Finish**.

The screen will clear while the settings are being stored. The screen will then will turn black for several seconds while the thin client is restarting. When the thin client has restarted, the Terminal Connection Manager screen will be presented.

Creating Connections

Overview of the Terminal Connection Manager

The Terminal Connection Manager window is displayed after the setup process, and each time you subsequently power on the thin client.



NOTE: IN THE FOLLOWING SITUATIONS, THE TERMINAL CONNECTION MANAGER WILL *NOT* BE DISPLAYED WHEN THE THIN CLIENT IS SWITCHED ON.

- IF YOU CONFIGURE A CONNECTION FOR AUTOSTART MODE, THE THIN CLIENT AUTOMATICALLY STARTS THE PARTICULAR CONNECTION, INSTEAD OF DISPLAYING THE TERMINAL CONNECTION MANAGER.
- IF YOU RESTORE PROPERTIES OF THE THIN CLIENT TO THE FACTORY DEFAULT SETTINGS, THE THIN CLIENT AUTOMATICALLY STARTS THE SETUP WIZARD INSTEAD OF DISPLAYING THE TERMINAL CONNECTION MANAGER.

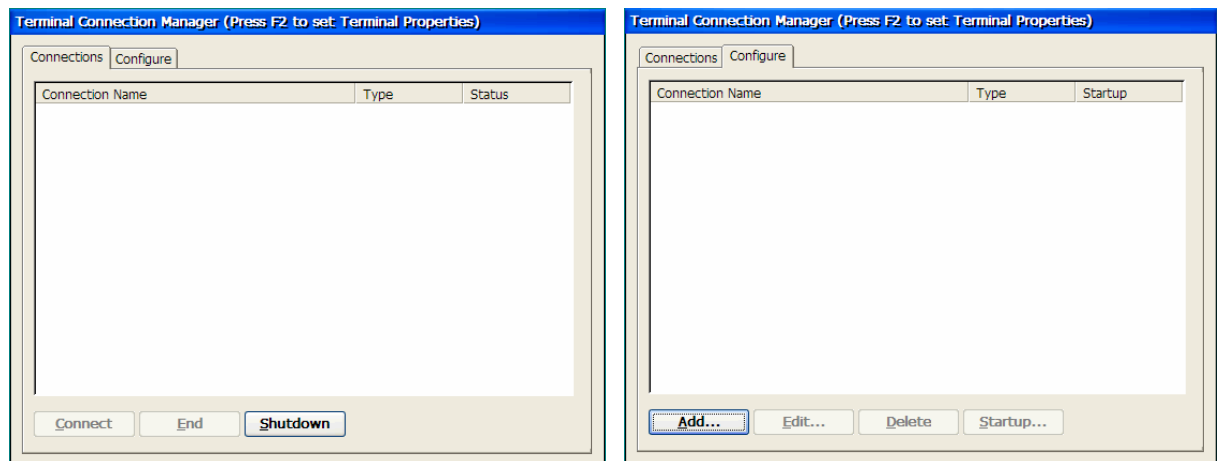

The Terminal Connection Manager has two tabs:

- The **Connections** tab displays a list of available connections, and allows you to start/end connections.
- The **Configure** tab allows you to add, edit and delete connections, and to specify startup properties for defined connections.



TIP: AT ANY TIME, YOU CAN INVOKE THE **TERMINAL CONNECTION MANAGER** FROM AN OPEN SESSION, BY PRESSING **Ctrl+Alt+End**. TO RETURN TO AN OPEN SESSION AND TO SWITCH BETWEEN SESSIONS, PRESS **Ctrl+Alt+↑** OR **Ctrl+Alt+↓**.

Connections Tab

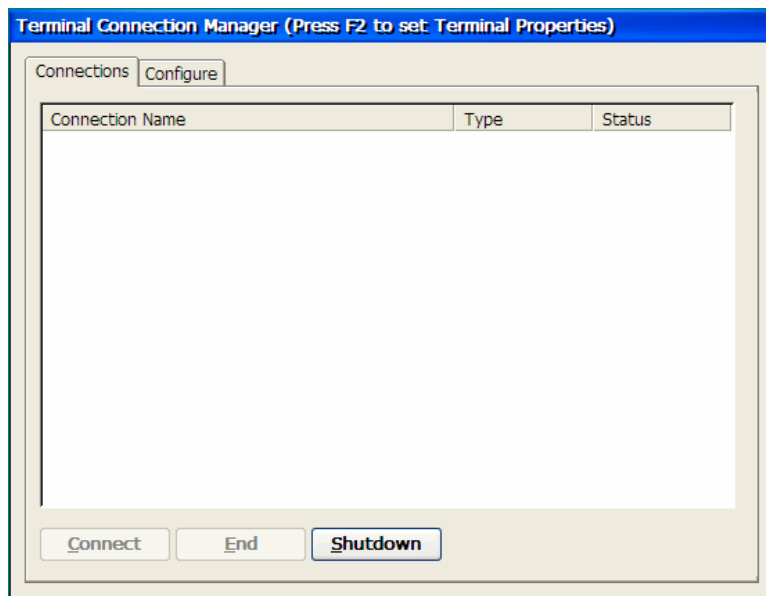

The Connections tab has the following buttons and a list (initially empty) of defined connections.

- **Connect:** to start a highlighted connection. You can also start a connection by double clicking on it.
- **End:** to close an active connection
- **Shutdown:** to logout of or to shutdown the thin client

The list area has the following columns that list the name of the connection and the type of connection. The connection types are abbreviated.

- **Connection Name** is the name given to this connection when it was created.
- **Type** identifies the type of connection
- **Status** indicates the connection's status

The following table describes what each abbreviation represents:

Connection Type	Description
Dialup	Dial-up connection to a remote server.
ICA	LAN connection to a server that supports Citrix's ICA protocol.
IOP	I-O 5250 Printer connection
Word	Microsoft word processing viewer
E-mail	Microsoft e-mail client
Image	Microsoft image viewer
PDF	Microsoft PDF file viewer
PowerPoint	Microsoft presentation viewer
Excel	Microsoft spread sheet viewer
RDP	LAN connection to a Windows Terminal Server
TEC	Terminal emulation connection
IE6	Internet Explorer

Configure Tab

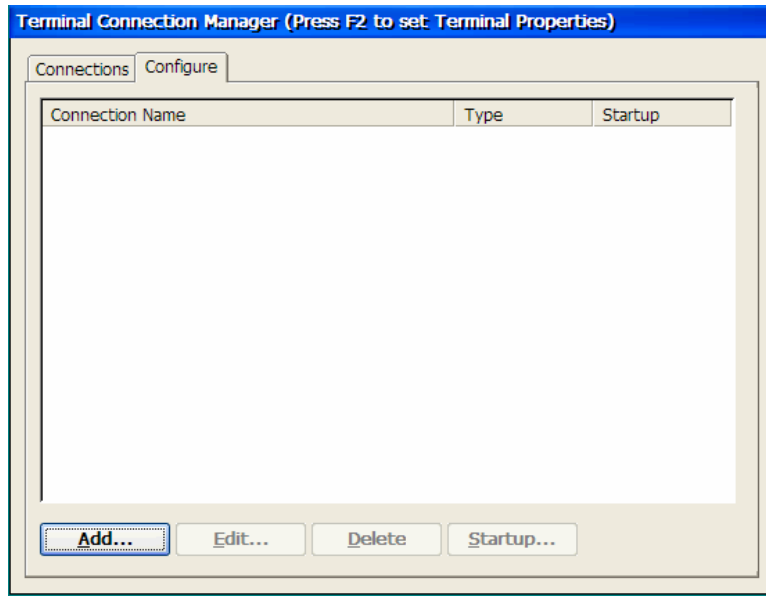

The Configure tab contains four buttons and a list (initially empty) of defined connections.

- **Add...** creates a connection entry using the New Connection wizard.
- **Edit...** edits defined connections.
- **Delete** defined connections.
- **Startup...** designates a particular connection to be the default connection, or to automatically start when the thin client is switched on. The startup status is displayed in the Startup column on the Connections Tab.

Creating Connections

This section describes the basic procedure for creating connections.

1. Click the **Configure** tab in the **Terminal Connection Manager**.
2. Click the **Add** button to display the New Connection dialog box.

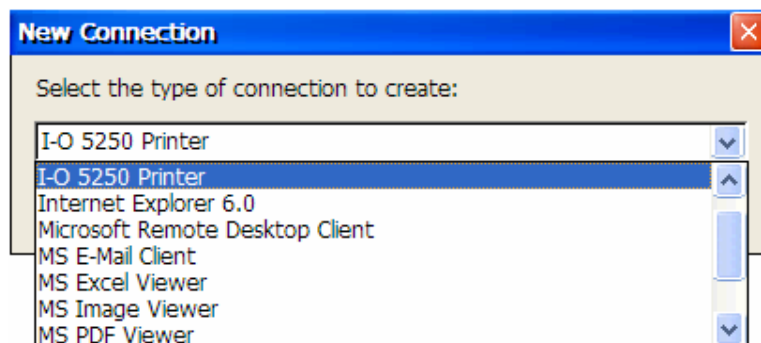

3. From the **New Connection** dialog box, scroll up or down to the desired connection type. **Click** on the connection.

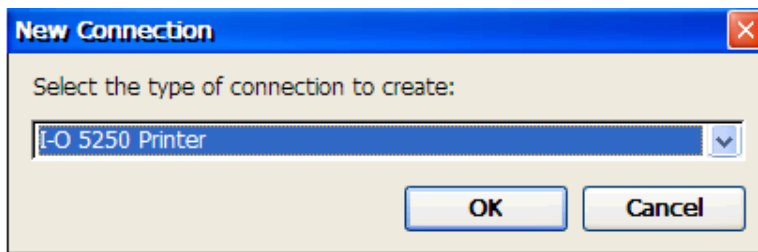

4. Click **OK**.
5. Certain connections will start a configuration wizard. Follow the wizard prompts. Refer to the appropriate sections in this manual for more information on configuring the different type of connections.



TIP: FOR MORE DETAILED CONFIGURATION INFORMATION, ADDITIONAL GUIDES FOR THE TN5250E PRINTING, TERMINAL EMULATION AND ICA CLIENT ARE INCLUDED ON THE CD OR ARE ACCESSIBLE THROUGH THE CONFIGURATION UTILITY'S HELP MENU.

Specifying AutoStart / Default Connection

This section describes the procedure to configure the thin client to automatically start or highlight a particular connection when the thin client is switched on.

1. Select the **Configure** sheet from the **Terminal Connection Manager** window.
2. Click on the connection for which you want to specify AutoStart or Default properties.
3. Click the **Startup...** button. The Connection Startup dialog-box is displayed.

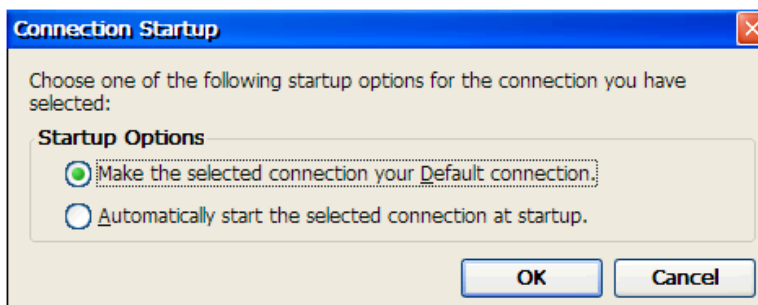

The above dialog-box has two radio-buttons:

- Make the selected connection your default connection

If you select this radio-button, the connection you selected in step 2 will be highlighted every time you switch on the thin client. The word **Default** will be displayed in the **Startup** column of the **Configure** tab of the **Terminal Connection Manager**.

- Automatically start the selected connection at startup

If you select this radio-button, the connection you selected in step 2 will be automatically started every time you switch on the thin client. The word **AutoStart** will be displayed in the **Startup** column of the **Configure** tab of the **Terminal Connection Manager**.

4. After configuring the default and auto-start properties, click **OK** to return to the Configure screen.

Editing a Connection

1. Select the Configure sheet from the Terminal Connection Manager window.
2. Highlight the connection to be edited.



NOTE: CONNECTIONS CANNOT BE EDITED WHILE THEY ARE ACTIVE.

3. Click the Edit... button. A wizard, similar to the Connection wizard that has been described earlier in the guide is displayed. For some connections, there are no configuration values that can be edited.

Deleting a Connection

1. Select the **Configure** tab from the Terminal Connection Manager window.
2. Highlight the connection to be deleted, and click the **Delete** button. A **Confirm Connection Delete** prompt is displayed.

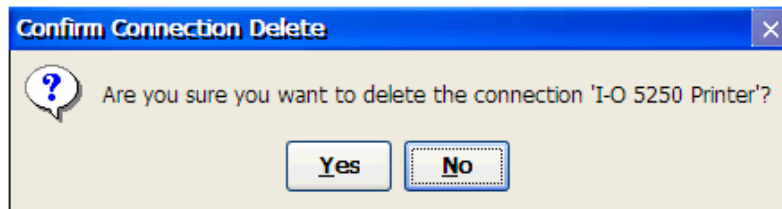

3. Click **Yes** to confirm deletion and **No** to cancel the delete command.

Starting a Connection

1. Select the Connections tab from the Terminal Connection Manager window.
2. Highlight the connection to start. Click Connect.



NOTE: YOU CAN ALSO DOUBLE-CLICK ON THE CONNECTION TO START THE CONNECTION.

Switching Connections

When more than one connection is active, you can switch between connections by using these key combinations:

- To cycle through active connections, press **CTRL+ALT+UPARROW** or **CTRL+ALT+DOWNARROW**.
- To return to the Connection Manager, press **CTRL+ALT+END**.

Closing a Connection

1. **Save** the current document, file, etc. if applicable.
2. **Logout** of the session (such as an 5250 terminal, RDP or ICA session)
3. Click **File | Close**, or **File | Exit**, or double-click the “X” on the title line of the application.



CAUTION: CLOSING A CONNECTION BEFORE PROPERLY ENDING TERMINAL SESSIONS CAN CAUSE THE HOST TO BLOCK RESTARTING THE SESSION.

I-O 5250 Printing

I-O 5250 Printing for Thin Client is a simple to use IBM AS/400, iSeries or eServer i5 host printing emulation. Connection to the IBM host is accomplished over the Ethernet link using TN5250e (a TCP/IP printing protocol created for use with IBM AS/400, iSeries or eServer i5 hosts).

Configuration is required only on the thin client as the IBM host will automatically create a print device, writer and spooler. The IBM host will either create its own name for the printer session, or you may setup a name of your choice. However, the IBM host must be configured to use TCP/IP, TN5250e and set for automatic device configuration.

With TN5250e, the IBM host recognizes only one type of printer device, a 3812 (a laser printer). However, I-O's 5250 Printer Emulation for thin clients contains a 3812 to 4214 conversion capability. This allows not only laser printers, but dot-matrix and thermal printers to be attached to the thin client and appear to the IBM host as a 3812 laser printer.

Print jobs sent from the IBM host are issued in IBM's proprietary EBCDIC character set and use SNA Character String (SCS) command structure. The I-O 5250 Printer Emulation converts EBCDIC to ASCII and the SCS command structure to the printer's command structure (PCL, Epson, and Proprinter). The I-O 5250 Printer Emulation product can be customized to change the host print attributes if needed (CPI, page orientation, etc.)

I-O also has included a number of advanced features in the I-O 5250 Printer Emulation. These include the ability to send printer specific commands as part of the SCS data stream that the IBM host does not know the printer is capable of performing. Other features include I-O's bar code language, graphing language, and even color support.

I-O 5250 Printing emulation can be configured with the following features:

Printer sessions supported	1
Printer emulations supported	3812
3812 to 4214 SCS command conversion	Yes
Printer control screen	Yes
Command Pass-Thru™	Yes
Computer Output Reduction (COR)	Yes
Auto Print Orientation (APO)	Yes
Printer overrides host control option	Yes
Paper size control	Yes
Orientation	Yes
End of Line control	Yes
EBCDIC to ASCII translation	Yes
Parallel port connection	Yes
Serial port connection	Yes
USB port connection	Yes
Customizable Telnet port number	Yes
Host status indicator	Yes
Printer status indicator	Yes



NOTE: MORE DETAILED INFORMATION ABOUT THE CONFIGURATION OF THE I-O 5250 PRINTING MODULE IS PROVIDED IN THE *TN5250E PRINTER EMULATION USER'S GUIDE*. THIS GUIDE IS LOCATED ON THE CD SUPPLIED WITH THE THIN CLIENT. IT MAY ALSO BE ACCESSED FROM THE CONFIGURATION UTILITY'S HELP MENU.

Configure the AS/400, iSeries or eServer i5 for TN5250e

TN5250e is an extension of the Telnet display and printer protocol used in the IBM AS/400 systems. I-O has customized the TN5250e protocol used in I-O 5250 Printer Emulation modules to include the same laser and dot-matrix printer emulations as are used in all I-O LAN Printer Server products. The host AS/400 sees a TN5250e printer as a 3812 page printer, yet I-O's LAN Print Servers allow you to attach either laser or dot matrix printers.

I-O recommends using TN5250e as the preferred AS/400 LAN printing protocol over the TCP/IP LPR/LPD printing processes. This is because TN5250e is easy to configure, fast in operation, and with I-O's enhanced printer emulations provides nearly the same functionality as an twinax-attached printer for both laser and dot-matrix printers.

To configure your AS/400 to support TN5250e printing, the AS/400 must meet the following requirements:

- Be running OS/400 V3R2 or newer, with the most recent applicable PTF's applied.
- Have the most recent version of Client Access installed on the AS/400.
- Have the most recent version of the Telnet server installed on the AS/400.
- Have the AS/400's auto configuration function turned on.

Make certain that the AS/400 can create virtual devices and there are a sufficient number of devices available to be created.

This is done using the AS/400 command:

```
CHGSYSVAL SYSVAL(QAUTOVRT) + VALUE(?)
```

The "?" is the maximum number of user-created virtual devices that can be created.

- If the OS/400 version is earlier than V4R2, the Telnet server will need to be started using the AS/400 command:

```
STRTCPSVR SERVER(*TELNET)
```

V4R2 and newer versions will automatically start the Telnet server.

After these requirements are met, the AS/400 (referred herein as IBM host or host) will automatically configure the I-O 5250 Printer session the first time you attempt to make a connection. The IBM host will create a 3812 paper printer device and assign a device name, or use the name you determine when configuring the I-O 5250 Printer session.

Create the I-O 5250 Printer Connection

This section will guide you through creating an TN5250e printer connection.



NOTE: MORE DETAILED INFORMATION ABOUT THE CONFIGURATION OF TERMINAL EMULATION CONNECTIONS IS PROVIDED IN THE **TN5250e Printer Emulation User's Guide**. THIS GUIDE IS LOCATED ON THE CD SUPPLIED WITH THE THIN CLIENT. IT MAY ALSO BE ACCESSED FROM THE CONFIGURATION UTILITY'S HELP MENU.



NOTE: ONLY ONE I-O 5250 PRINTER CONNECTION MAY BE CREATED.

1. Click the **Configure** tab in the **Terminal Connection Manager** then click the **Add** button to display the **New Connection** dialog box.
2. Click **Add**.... The **New Connection** dialog-box is displayed.

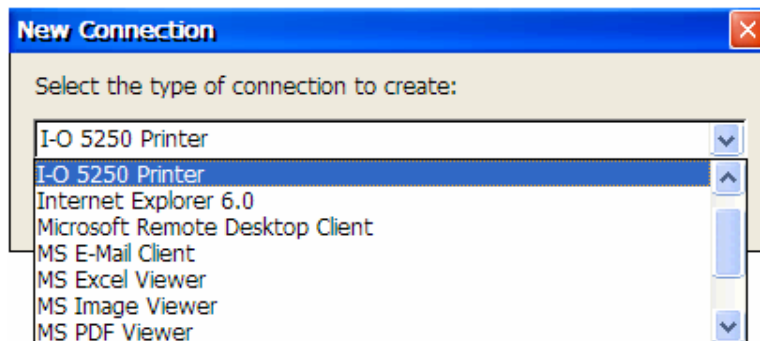

3. Select **I-O 5250 Printer** from the drop-down list and click **OK**. The I-O 5250 Printer Connection configuration screen is displayed.



NOTE: ONLY ONE 5250 PRINTER CONNECTION CAN BE CREATED. IF MORE THAN ONE IBM HOST PRINTER CONNECTION IS REQUIRED, INSTALL ONE OF I-O'S MULTI-SESSION LAN PRINT SERVERS.

4. On **General** tab, you will enter the basic required information for establishing a TN5250e printer connection with the IBM host.

- **IBM Host Printer Name:** Enter the name that you want the IBM host to use for this printer session (up to 8 characters maximum).



CAUTION: IF YOU LEAVE THIS FIELD BLANK, THE IBM HOST WILL CREATE A 3812 DEVICE BUT WILL GIVE THE PRINTER THE NAME OF QPADEVNNNN WITH NNNN BEING A 4-DIGIT NUMBER. HOWEVER, EACH TIME THE I-O PRINT SERVER CONNECTS TO THE IBM HOST, THE NNNN NUMBER FOR THE PRINTER MAY

BE DIFFERENT. THIS MAY CAUSE PROBLEMS WHERE A SPECIFIC PRINTER NAME IS USED IN SPECIFYING THE LOCATION OF PRINTED OUTPUT. *IT IS RECOMMENDED THAT YOU ENTER A PRINTER NAME!*

- **IBM Host IP Address:** Enter the TCP/IP address of the IBM host the I-O 5250 Printer session will be connected to.
- **Printer Driver:** From the drop down box, select the print driver supported by the printer attached to the thin client.

For example, if you were attaching a HP LaserJet printer, you would select "HP PCL". For Epson, there are several general drivers. Select the one that most closely matches the Epson or Epson compatible dot-matrix printer that is being attached.

It should be noted that the IBM host will always create a 3812 page printer device whenever TN5250e is used for printing. This is a laser printer. To allow you to attach other printers besides laser printers, I-O's 5250 Printer Emulation module contains a 3812 to 4214 conversion module. If you choose to attach a dot-matrix printer to the thin client and select one of the dot-matrix print drivers listed in the drop down box, I-O's 5250 Printer Emulation module will first convert the 3812 SCS commands into 4214 SCS commands. Those 4214 SCS will then be converted into the appropriate ASCII dot-matrix commands. To the IBM host, the attached dot-matrix printer appears as a 3812 page printer.



NOTE: BECAUSE THERE ARE DIFFERENCES IN THE WAY THAT LASER PRINTERS AND DOT-MATRIX PRINTERS FUNCTION, NOT ALL OF THE NATIVE IBM HOST DOT-MATRIX FUNCTIONALITY IS AVAILABLE THROUGH THIS CONVERSION PROCESS DUE TO THE FACT THAT THE IBM HOST IS ONLY SENDING 3812 COMMANDS. SUCH FEATURES AS "LINE ALIGNMENT" USED FOR ALIGNING CHECKS PRIOR TO PRINTING CAN ONLY BE OBTAINED USING A TRUE IBM 4214/5224/5225/5256 DOT-MATRIX EMULATION. FOR SUCH APPLICATIONS, I-O RECOMMENDS THAT YOU USE ONE OF I-O'S LAN PRINT SERVER PRODUCTS TO PROVIDE THE COMPLETE IBM DOT-MATRIX FUNCTIONALITY.

- **Local Port:** Select from the drop down box the physical port that the printer is attached.
 - **Baud Rate:** If the COM1 serial port is the physical port the printer is attached, identify here the speed of the port (make this rate the same as that set on the printer). The remainder of the serial characteristics for this port have been set to: 8 data bits, no parity, 1 stop bit. This field is only available when COM1 is selected in the Local Port field.
5. Select the **Language** tab. From the drop down box, select the host language to be used by the IBM host when the command "Use Default Language" is received.

- **Language:** Select the appropriate language from the drop down box.
- **Edit EBCDIC Translation Table:** Use this option to change the translation table that the I-O 5250 Printer Emulation module uses to convert IBM's EBCDIC characters to ASCII characters.



CAUTION: EDITING THIS TABLE SHOULD ONLY BE ATTEMPTED BY ADVANCED USERS.

If a character is printing on your printer with the wrong ASCII value, use the printer's manual to determine the ASCII HEX value of this character and that of the value you want in its place. Then edit the translation table with by changing the incorrect ASCII value to the desired value.

- **EBCDIC:** Enter the hexadecimal EBCDIC value you want to change.

- **ASCII:** Enter the hexadecimal ASCII value for the character you actually want printed.

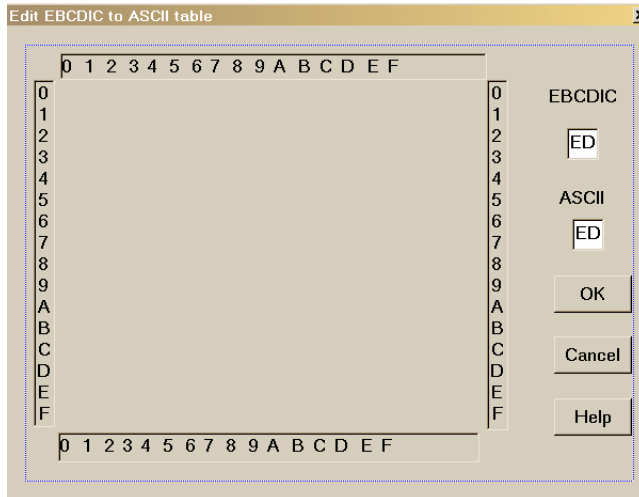

(Similar to actual screen)



NOTE: I-O USES IBM'S MULTINATIONAL CODE PAGE 500 (WITH MODIFICATIONS FOR THE SELECTED LANGUAGE) FOR THE EBCDIC TABLE AND THEN CONVERTS TO ASCII CODE PAGE 850 AS THE DEFAULT CONVERSION. USING HOST DOWNLOAD COMMAND 17, YOU MAY CHANGE THE ASCII TABLE TO ROMAN 8, LATIN 1 (INCLUDES EURO SYMBOL), CODE PAGE 437, OR CODE PAGE 858 (INCLUDES EURO SYMBOL).

6. Select the **Advanced Features** tab. Enter the values the IBM host uses for the message queue, library and Telnet port number.



NOTE: YOU NORMALLY DO NOT NEED TO MODIFY THESE VALUES AS THEY ARE THE TN5250E DEFAULTS. REFER TO YOUR SYSTEM ADMINISTRATOR FOR ANY CHANGES HERE.

- **AS/400 Queue Name:** Enter the name of the message queue on the IBM host. The default value is QSYSOPR.
 - **AS/400 Library Name:** Enter the name of the library on the IBM host. The default value is *LIBL.
 - **Telnet Port Number:** Enter the TCP/IP port for Telnet on the IBM host. The default value is 23. If a firewall is being used, port 23 may be blocked to prevent unwanted access to your network and hosts. In such a case, the port number would be changed to another number. The maximum value is 65535.
7. When you have completed making all configuration entries on the General, Language and Advanced Features screens, click the **OK** on the title bar. Pause a few moments while the thin client saves the changes (if adding a connection, a new entry will appear on the Terminal

Connection Manager screen). Then click the **Connections** tab on the Terminal Connection Manager screen.

Terminal Emulation

This section describes the basic procedure for creating an IBM 5250 terminal display emulation connection that will use TCP/IP and the network port of the thin client.



NOTE: FOR INSTRUCTIONS ON CREATING OTHER TYPES OF TERMINAL EMULATION CONNECTIONS, SUCH AS IBM 3270, DEC VT, UNIX, ETC., REFER TO THE **Terminal Emulation User's Guide**. THIS GUIDE IS LOCATED ON THE CD SUPPLIED WITH THE THIN CLIENT. IT MAY ALSO BE ACCESSED FROM THE CONFIGURATION UTILITY'S HELP MENU.



NOTE: UP TO 20 TERMINAL EMULATION CONNECTIONS MAY USED CONCURRENTLY. MORE CONNECTIONS MAY BE CREATED, BUT ACTUAL USAGE IS LIMITED TO 20 ACTIVE CONNECTIONS.

1. Click the **Configure** tab in the **Terminal Connection Manager** then click the **Add** button to display the **New Connection** dialog box.

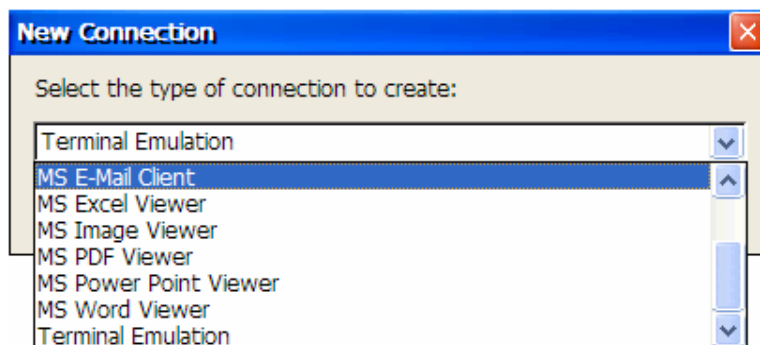

2. Select **Terminal Emulation** and click **OK**. The **Connection Information** dialog box will be displayed.

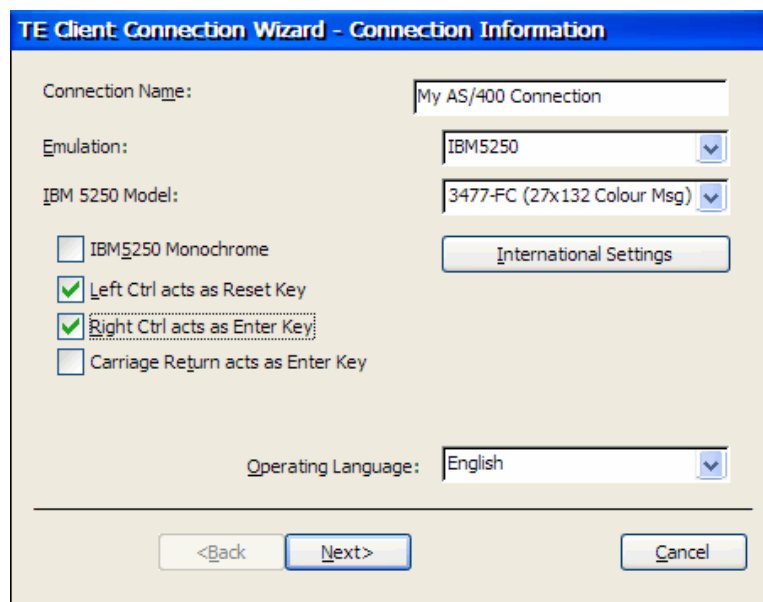

3. On the Connection Information screen, you will select the emulation type, model, language and keyboard options. After all the settings have been made, click **Next>** to continue.
 - **Connection Name:** Enter a name for this session that will appear on the Terminal Connection Manager screen. The connection name can consist of a maximum of 42 characters (including special characters).
 - **Emulation:** Select the terminal emulation.

- **IBM 5250 Model:** Select the model type in the list box.
- **IBM 5250 Monochrome:** Check the box if a monochrome monitor is attached.
- **Left Ctrl acts as Reset Key:** If using the I-O 122-key 5250 Thin Client Keyboard, check this box. If using a standard 104/105 Windows keyboard, check this box if desired.
- **Right Ctrl acts as Enter :** If using the I-O 122-key 5250 Thin Client Keyboard, check this box. If using a standard 104/105 Windows keyboard, check this box if desired.
- **Carriage Return acts as Enter :** Check this box if desired.
- **Operating Language:** Specify the language to be used in all menus and dialog boxes by making a selection in the list at the bottom of the dialog box.

Click **Ok** to continue.

4. On the Host Information screen, host connection information will be entered. .

- **TCP/IP:** Select this radio button for an Ethernet connection,
 - **Modem:** Refer to the Terminal Emulation User's Guide for detailed instructions.
 - **Serial:** Refer to the Terminal Emulation User's Guide for detailed instructions.
 - **Host Name:** Enter IP address of the host computer, or if available, enter the DNS/WINS name of the host computer.
 - **Host Rollover On Connection Fail:** Check this box if there are alternate hosts that the thin client is to attempt to connect to if the primary host is not available. The screen will be changed to display additional host field. Enter the IP Address or DNS/WINS address of each alternate host.
5. Click **Advanced**. The TCP/IP Telnet Configuration dialog-box is displayed. After configuring these advanced TCP/IP settings, click **OK** to return to the Host Information dialog-box, and then click **Next>** to continue.



NOTE: FOR 5250 EMULATION, NO CHANGES ARE REQUIRED TO THE SETTINGS IN THIS DIALOG BOX. HOWEVER, IF THE HOST SESSION NAME IS TO BE ASSIGNED OR THE AUTOSTART FEATURE IS TO BE USED, THEN SETTINGS IN THE **5250 OPTIONS** AREA ARE REQUIRED.

- **Host Port Number:** Provide the Telnet port number. The default value is **23**. You can specify any valid 16-bit port number. If you specify an invalid port number, this field will be set to **one**.
 - **Local Port Number:** In this field, you can specify the local Telnet port number. If you want the port number to be allocated automatically, set this field to **zero**.
 - **Telnet Name:** It is recommended that this name not be changed. This is the model type that will be reported to the host.
 - **Enable Keep Alives:** Selecting this option will prevent the session from being disconnected from the host by an inactivity timeout.
 - **Suppress | Echo:** Select this check-box to prevent the emulation from echoing (repeating) keystrokes.
 - **Suppress | TN5250E:** Select this check-box to suppress support for the TN5250E option.
 - **Force Negotiation:** These settings determine whether or not the Telnet support for **Binary** and **EOR** options are supported. The default setting for both options is **No**.
No: This setting will not force negotiations. The host has to decide whether to support the option.
Do: This setting will force negotiation; the host will be informed that the option is supported.
Don't: This option will force negotiation. A negotiation packet will be sent informing the host that the option is not supported.
 - **Break Settings:** The setting of these options determine whether or not a timing mark (**TM**) and/or carriage return (**CR**) is sent with a Telnet break packet. A timing mark is sent by default.
6. Click the **5250 Options** button to configure the 5250 options. After configuring 5250 Options and Advanced TCP/IP settings, click **OK** twice to return to the Host Information dialog-box, and then click **Next>** to continue.



NOTE: IF THE HOST IS TO ASSIGN ITS OWN SESSION NAMES AND THE NORMAL 5250 LOGIN IS DESIRED, NO ENTRIES ARE REQUIRED IN THIS DIALOG BOX . THE HOST WILL AUTOMATICALLY ASSIGN A NAME IN THE FORMAT OF QPADEV????



TIP: THIS DIALOG BOX IS ONLY DISPLAYED BY CLICKING THE 5250 OPTIONS BUTTON IN THE TCP/IP TELNET CONFIGURATION DIALOG BOX WHEN TN5250E IS NOT SUPPRESSED AND THE IBM 5250 MODEL IS NOT SET TO 3812-1 OR 5553-B01 PRINTERS.

- **Device Name:** This enables you to enter the name of the device which the server will be requested to assign to this Telnet session. If left blank, the host will assign a name in the format of QPADEV????.
- **User, Password, Library, Menu:** These options enable you to specify the initial entries required on the standard startup screen so that it can be bypassed. Each entry can be a maximum of ten characters.
- **Program:** This enables you to specify the name of the initial program to run. The entry can be a maximum of ten characters.

Click **OK** twice to return to the Host Information dialog-box, and then click **Next>** to continue.

7. The Advanced Options screen allows access to additional optional configuration screens.



NOTE: FOR 5250 EMULATION, ONLY THE GUI OVERRIDES OPTIONS MAY BE USEFUL. REFER TO THE **TERMINAL EMULATION USER'S GUIDE** FOR INSTRUCTIONS ON THE USE OF THESE OPTIONAL CONFIGURATION SELECTIONS.

RDP

Remote Desktop Protocol (RDP) allows a "thin client" to communicate with a terminal server across a Local Area Network (LAN) or Wide Area Network (WAN) by means of a dial-up, Integrated Services Digital Network (ISDN), Digital Subscriber, Line (DSL), or Virtual Private Network (VPN) connection. RDP is designed to provide remote display and input capabilities over network connections for Windows-based applications running on a server.

This section describes the procedure to create a connection to a Windows Terminal Server using Microsoft's Remote Desktop Protocol.



NOTE: PLEASE REFER TO YOUR MICROSOFT CERTIFIED SYSTEMS ENGINEER (MCSE) FOR ASSISTANCE IN CREATING AND CONFIGURING RDP CONNECTIONS, AND USING THE THIN CLIENT IN MICROSOFT'S TERMINAL SERVER ENVIRONMENT.

1. Click the **Configure** tab in the **Terminal Connection Manager** then click the **Add** button to display the **New Connection** dialog box.

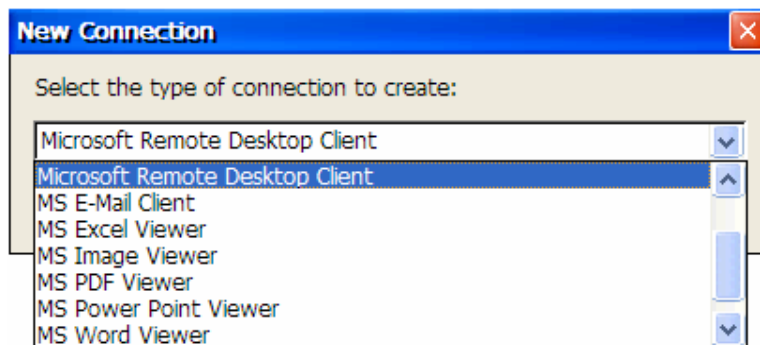

2. Select **Microsoft Remote Desktop Client** from the drop-down list and click **OK**. The first dialog-box of the **WTS Connection Wizard** is displayed.

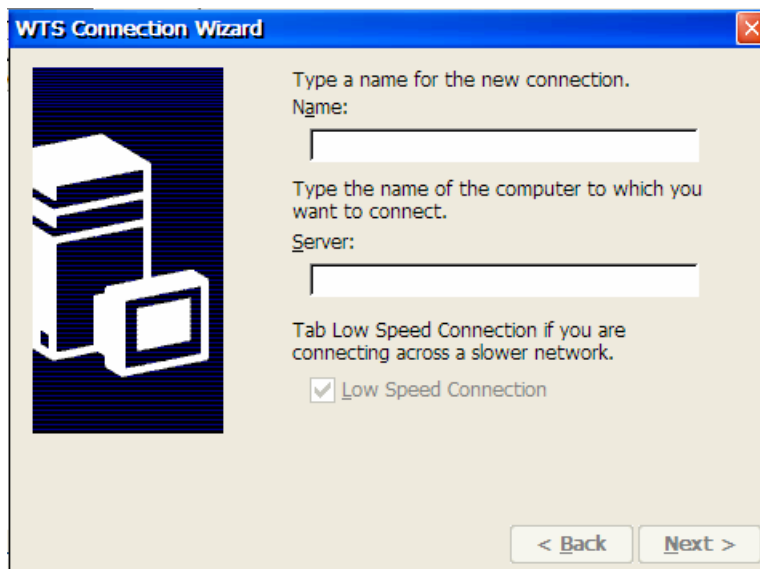

3. Provide a unique name for the new connection, and the IP address of the server in the **Name** and **Server** fields respectively. The connection name that you provide here will be displayed in the **Terminal Connection Manager** window.



TIP: IF THE NETWORK HAS A WINS SERVER, YOU CAN PROVIDE THE NAME (*INSTEAD OF IP ADDRESS*) OF THE SERVER IN THE **SERVER** FIELD.

If you are connecting across a slow network (*for instance, a WAN*), enable the **Low Speed Connection** check-box. This setting causes data to be compressed before transmission, thus optimizing the bandwidth usage. Note that while data compression reduces the transmission time, it consumes more processor resources.

Click **Next>** to continue. The following dialog-box is displayed.

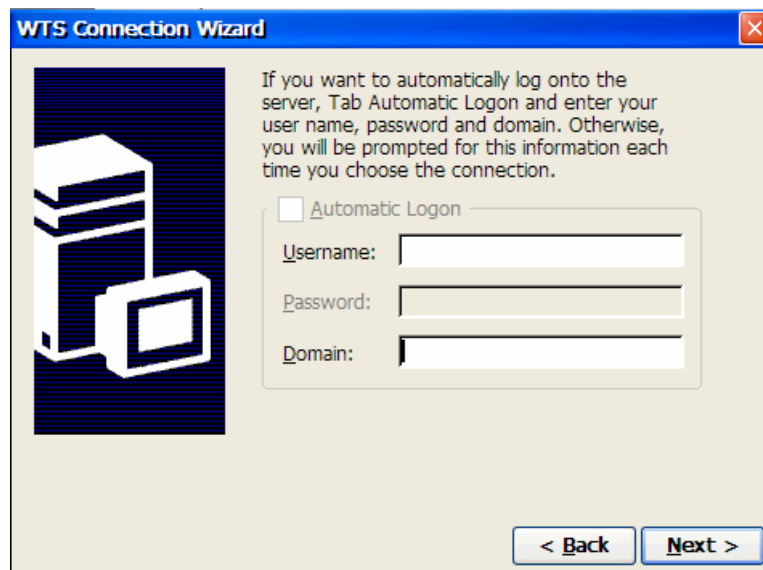

- Information that you provide in the above dialog-box will be used to automatically logon to the server after the connection is started. Select the **Automatic Logon** check-box to enable the **Username**, **Password** and **Domain** fields and provide appropriate input.

If you do not enable the **Automatic Logon** option, a login prompt will be displayed each time you start the connection.

Click **Next>** to proceed. The following dialog-box is displayed.

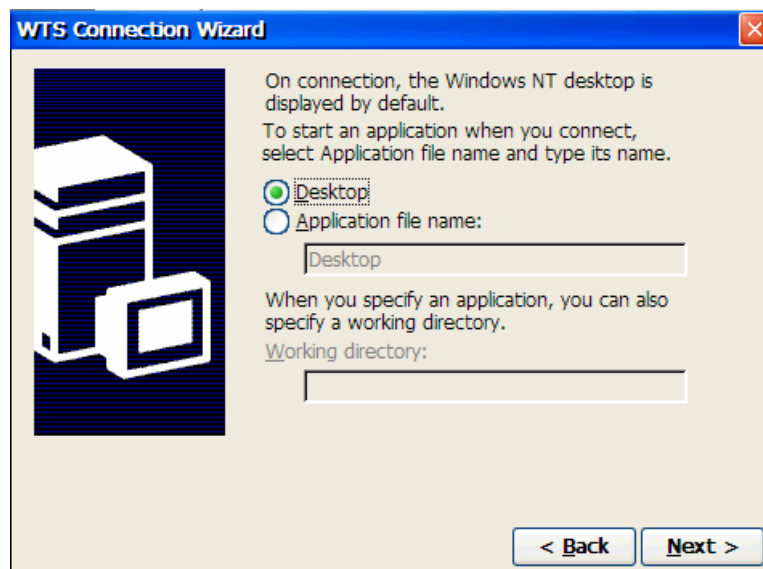

- After connecting to the server, the client displays the Windows desktop by default. Instead, if you want a particular application to be automatically started, select the **Application file name** radio button and provide the name and path of the application file in the text field beneath the **Application file name** radio-button. You can specify a working directory in the **Working directory** field.

Click **Next>** to continue. The following dialog-box is displayed.

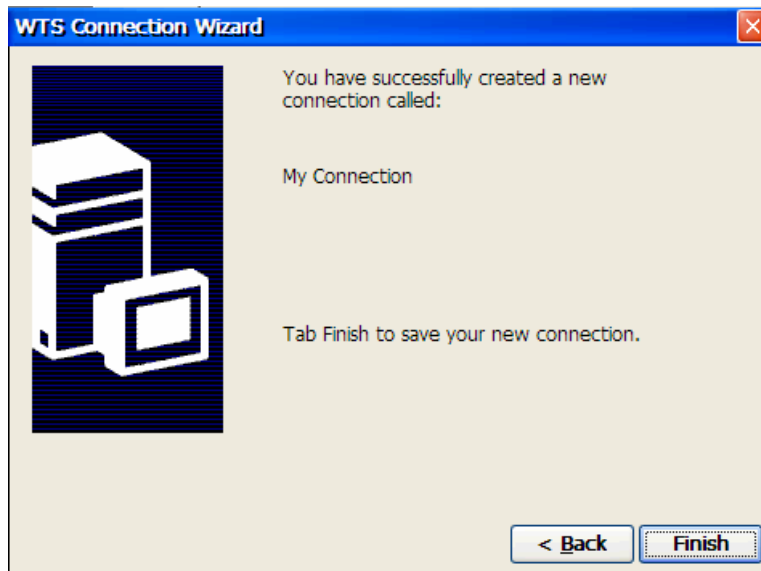

6. The above dialog-box marks the end of the **WTS Connection Wizard**. Click **Finish** to complete the process. The name of the connection you created will be added to the list of connections displayed in the **Connections** tab of the **Terminal Connection Manager** window.

ICA

The Citrix **Independent Computing Architecture (ICA)** is a general-purpose distributed presentation services architecture. ICA is network protocol used by Windows based servers running Citrix MetaFrame XP Presentation Sever, Metaframe, or WinFrame. The ICA technology shifts the application processing from client to server. It is a core technology of Citrix MetaFrame server-based computing software. ICA helps organizations reduce total cost of ownership by delivering business-critical applications over heterogeneous computing environments. It also safeguards application performance, data security, and administrative control. The ICA protocol sends only keystrokes, mouse clicks, and screen update signals across the network. Applications consume just a fraction of the network bandwidth usually required.

You can create, configure and run two types of ICA sessions: server connectins and published applications:

- Server connections allow user to connect to a specific computer running MetaFrame Presentation Server. Users can run any applications available on the desktop, and in any order.
- Published applications are specific applications set up by an administrator for remote users to run. When connected, users are presented with the application itself.

The following procedure describes hot to create connections to computers running MetaFrame Presentation Server.



NOTE: CITRIX RECOMMENDS THAT YOU QUICKLY CREATE A CONNECTION AS OUTLINED IN THE FOLLOWING PROCEDURE, AND THEN CONFIGURE THE CONNECTION TO BEST SUIT YOUR NEEDS. REFER TO THE **EDITING A CONNECTION USING CONNECTION MANAGER** SECTION OF THE **CLIENT FOR WINDOWS CE FOR WINDOWS-BASED TERMINALS ADMINISTRATOR'S GUIDE**. THIS GUIDE IS LOCATED ON THE CD SUPPLIED WITH THE THIN CLIENT. IT MAY ALSO BE ACCESSED FROM THE CONFIGURATION UTILITY'S HELP MENU.



NOTE: PLEASE REFER TO YOUR MICROSOFT CERTIFIED SYSTEMS ENGINEER (MCSE) FOR ASSISTANCE IN CREATING AND CONFIGURING RDP CONNECTIONS, AND USING THE THIN CLIENT IN MICROSOFT'S TERMINAL SERVER ENVIRONMENT.

1. Click the **Configure** tab in the **Terminal Connection Manager** then click the **Add** button to display the **New Connection** dialog box.

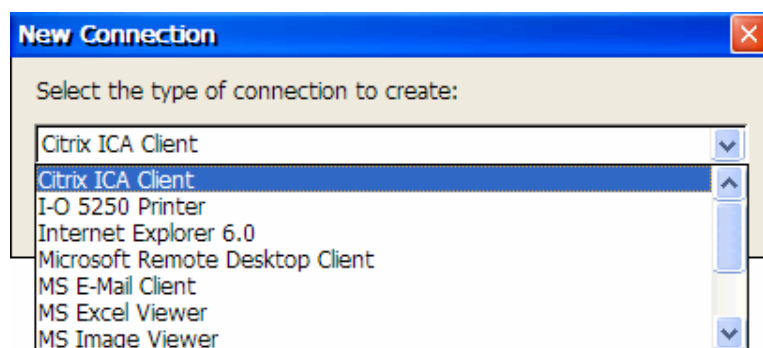

2. Select **Citrix ICA Client** from the drop-down list. The **Select a Server or Published Application** dialog box is displayed.

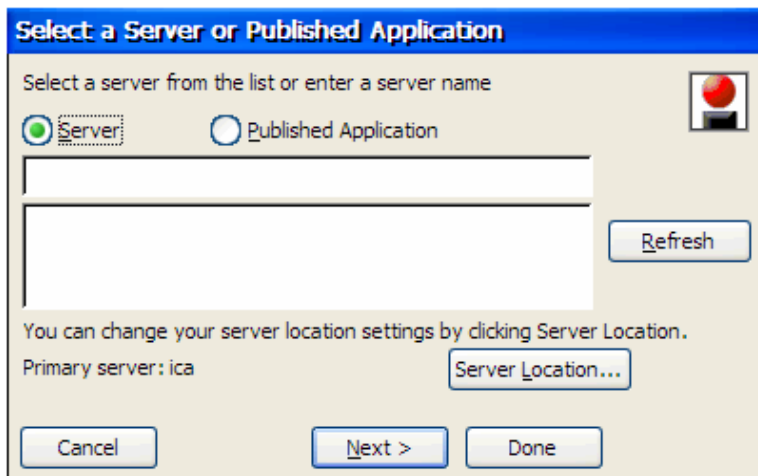

NOTE: DEPENDING UPON THE CITRIX SERVER ENVIRONMENT, IT MAY BE NECESSARY TO CHANGE THE DEFAULT ICA SETTINGS PRIOR TO CREATING AN ICA CONNECTION. REFER TO THE **EDITING THE GLOBAL AND DEFAULT SETTINGS** SECTION OF THE **CLIENT FOR WINDOWS CE FOR WINDOWS-BASED TERMINALS ADMINISTRATOR'S GUIDE**. THE GLOBAL ICA CLIENT SETTINGS ICON IS FOUND ON THE CONTROL PANEL OF THE TERMINAL PROPERTIES SCREEN. THIS CAN BE ACCESSED BY PRESSING F2 WHEN THE CONNECTION MANAGER SCREEN IS BEING DISPLAYED.

3. To connect to a server, click **Server**, or to connect to a **Published Application**. To display an up-to-date list of servers or application, click **Refresh**.
 - To define or change server groups or browser protocol, click **Server Location** and go to Step 4.

— or —
 - Scroll through the displayed list and select the server or published application. Click **Next** and go to Step 7.
4. The **Server Location** dialog box appears:

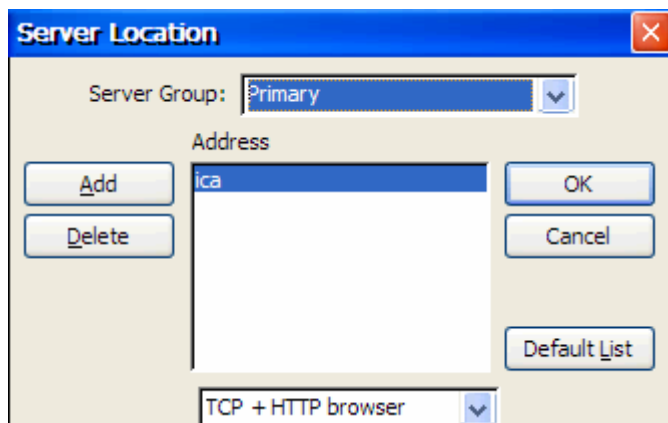

The client uses the information entered on the **Server Location** screen to help locate available servers and published applications.

The default server location protocol is **TCP+HTTP browser** and the default value entered in the **Address** box is **ica**.



NOTE: FOR MORE INFORMATION ABOUT CREATING AN SSL (OR A TLS) CONNECTION AND USING SSL+HTTPS OR UDP PROTOCOL, SEE THE **USING ENCRYPTION AND CONFIGURING NETWORK PROTOCOL AND SERVER LOCATION** SECTIONS OF THE **CLIENT FOR WINDOWS CE FOR WINDOWS-BASED TERMINALS ADMINISTRATOR'S GUIDE**.

5. Click **Add** and enter the IP Address/DNS name and the port number of the computer running MetaFrame Presentation Server on the remote network.
6. Click **OK**. The **Select a Title for the ICA Connection** dialog box appears.

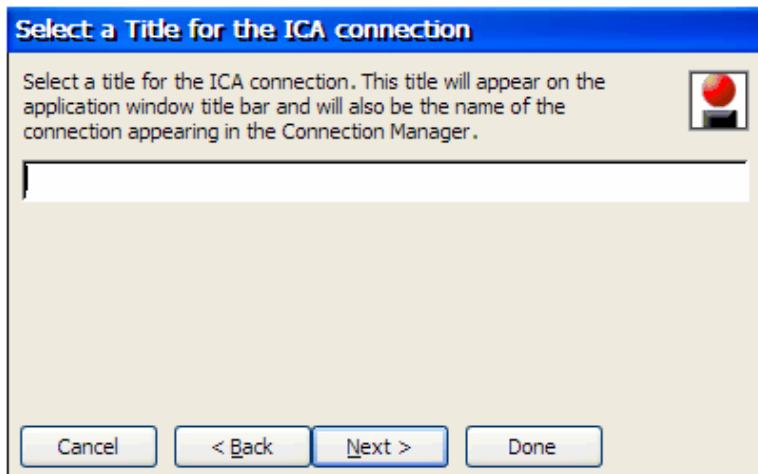

7. Enter a name for the connection



CAUTION: DO NOT USE THE FOLLOWING CHARACTERS IN YOUR CONNECTION NAME:
; , [] ' ! % ^ & * () @ # \ | \ < > ? /

8. Click **Done**. The connection name will appear in the list of connections in the Connection Manager.
9. To complete the process, edit the connection you just created. Refer to the **Editing a Connection Using Connection Manager** section of the **Client for Windows CE for Windows-Based Terminals Administrator's Guide**. This guide is located on the CD supplied with the thin client. It may also be accessed from the Configuration Utility's Help menu.

Microsoft Viewers

The thin client contains five viewers for files created in the following formats:

- Word
- Excel
- PowerPoint
- Image
- Acrobat PDF

When using the Internet Explorer browser or viewing an e-mail attachment, viewers are automatically loaded.

Before documents located on a USB storage device or a shared network drive (through Windows terminal services or Citrix) can be viewed, a viewer connection must be created.



TIP: IF YOU WILL NOT BE VIEWING FILES OTHER THAN WITHIN A BROWSER CONNECTION OR AS AN E-MAIL ATTACHMENT, THERE IS NO NEED TO ADD CONNECTIONS FOR THE VIEWERS.

1. Click the **Configure** tab in the **Terminal Connection Manager** then click the **Add** button to display the **New Connection** dialog box.

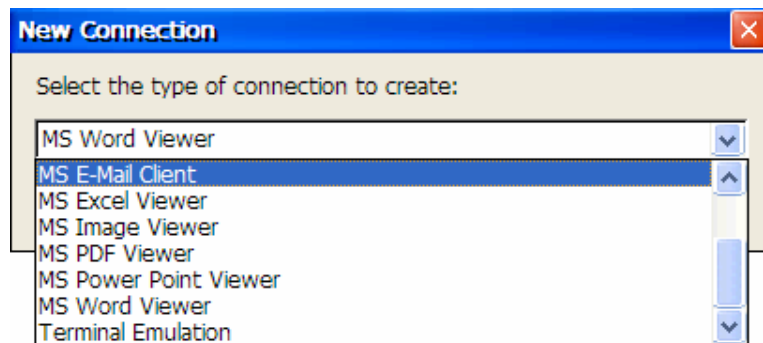

2. Select the desired viewer and click **OK**. A viewer entry will appear in the connections listing.

Internet Explorer

The thin client includes Microsoft's Internet Explorer V6 for CE. This smaller version of Internet Explorer is equivalent functionally to Internet Explorer V6. However, because the limited program storage area size, the CE version does not include on Help, has limited area for cookies and favorites storage. Also, because a thin client application cannot be updated in the same fashion as a standard Windows PC application can, add on features like plug ins are not available. If more robust browsing capability is required, a Windows Terminal Server or Citrix Metaframe server can provide access to Internet Explorer V6 or other browsers.

1. Click the **Configure** tab in the **Terminal Connection Manager** then click the **Add** button to display the **New Connection** dialog box.

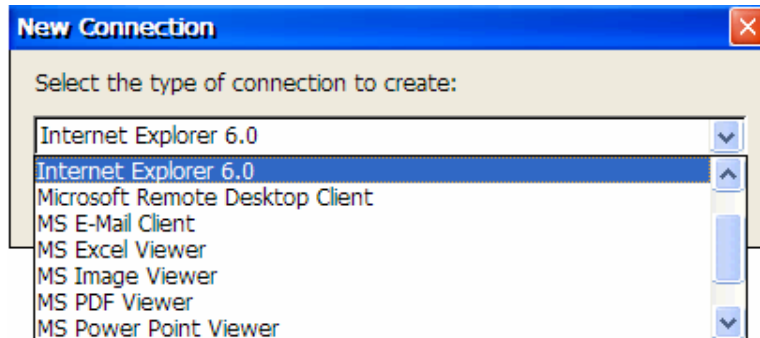

2. Select **Internet Explorer 6.0** and click **OK**. An Internet Explorer listing will appear in the List of Connections box.

E-Mail Client

The thin client includes an e-mail client that will allow you to send and receive e-mails through either a POP3 or IMAP4 e-mail server. The e-mail client will create its own folder hierarchy with four default folders: Inbox, Outbox, Deleted (local), and Sent. The messages you receive and send are stored in these folders. Messages attachments may alternately be stored on a USB storage device.

The e-mail client requires two major steps to setup – creating the connection and configuring the e-mail services so that e-mail can be accessed.

1. Click the **Configure** tab in the **Terminal Connection Manager** then click the **Add** button to display the **New Connection** dialog box.

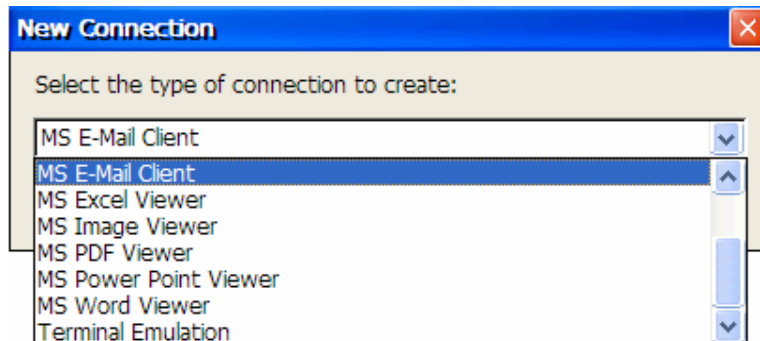

2. Select **MS E-Mail Client** and click **OK**. A new entry will appear in the connections listing.
3. Click on the **Connections** tab, then either **double-click** on the **E-Mail** connection, or highlight the E-mail connection and click on the Connection button.

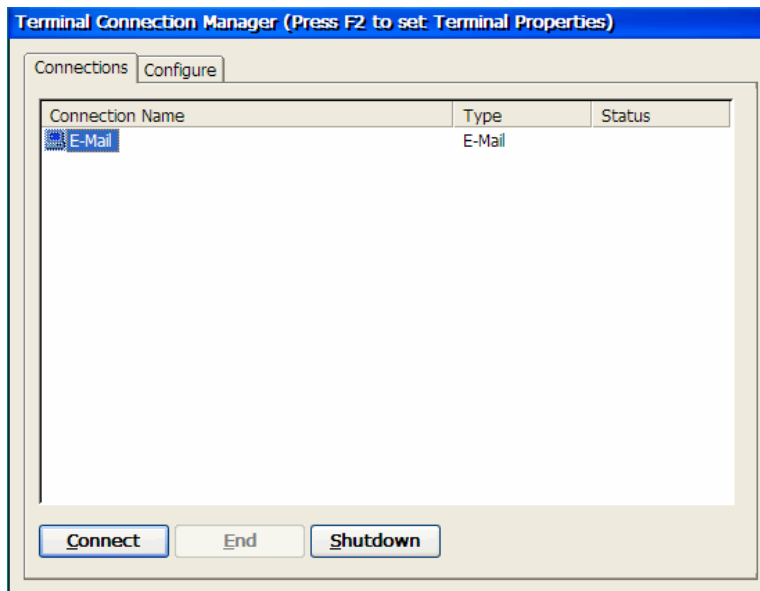

4. On the E-mail screen, click on the **Services** menu item. Then click the **Option...** menu item.

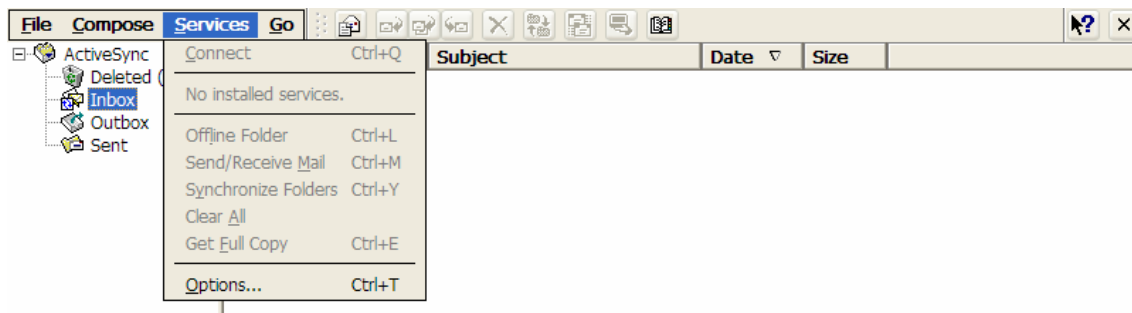

5. On the Options screen, click the **Add** button.

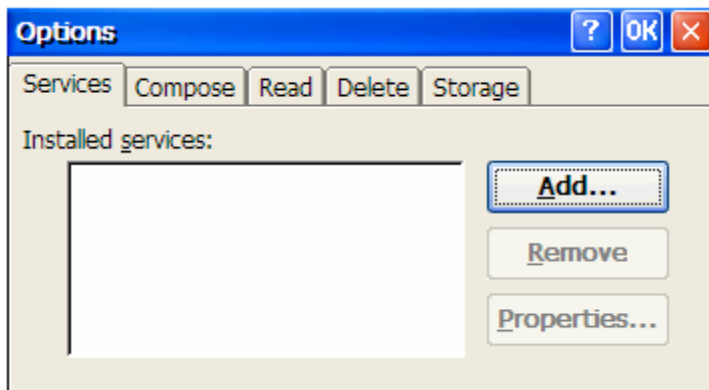

6. On the Service Name screen, **select the type** of e-mail server that you will be connecting to.

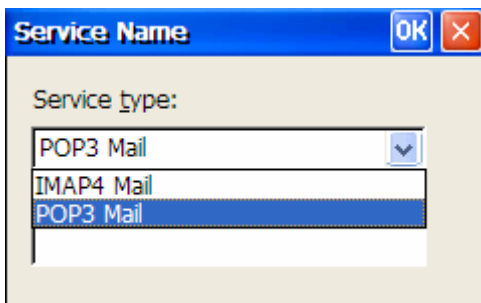

7. Also on the Service Name screen, enter a **name** you would like this service to appear as in the list of **Installed services** listing on the Options screen. Click **OK**.

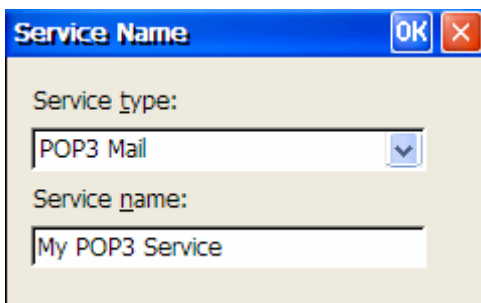

8. On the Service Definition screen, enter the following information. Click **Next** when done.

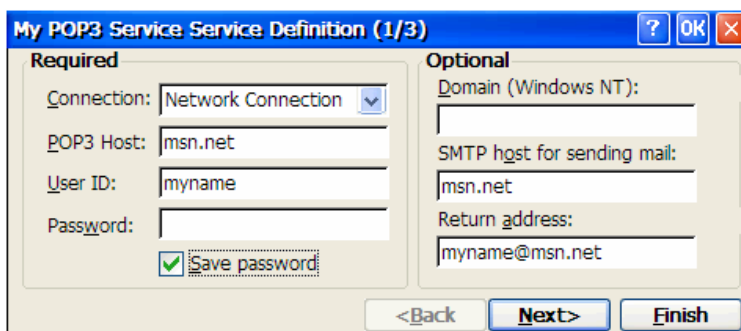

- **Connection:** Select **Network Connection** from the drop down list.
- **POP3 Host:** Enter the name of your e-mail server that you will use to send an receive messages.
- **IMAP4 Host:** Enter the name of your e-mail server that you will use to send an receive messages.
- **User ID:** Enter the user name or mailbox ID you will use to login into your e-mail server.
- **Password:** Enter the password. For security purposes, the password will not be displayed.

- **Save password:** Check this box to have the password saved when the e-mail connection is closed. This will eliminate the need to reenter the password each time you connect to the e-mail server.
- **Domain:** This field is not required for most ISP based e-mail servers. Enter the Windows NT domain name. This name is required only when connecting to network, such as a corporate intranet, that use Windows NT domain security. Refer to your system administrator for this information.
- **SMTP host for sending mail:** If your mail service uses a separate server for SMTP, enter the name here. POP3 service supplied by an ISP requires SMTP.
- **Return address:** Enter your e-mail address.

Click the **Next>** button when the above information is entered.

9. The General Preferences screen will be displayed. Select the connection settings, then click **Next>** to continue.

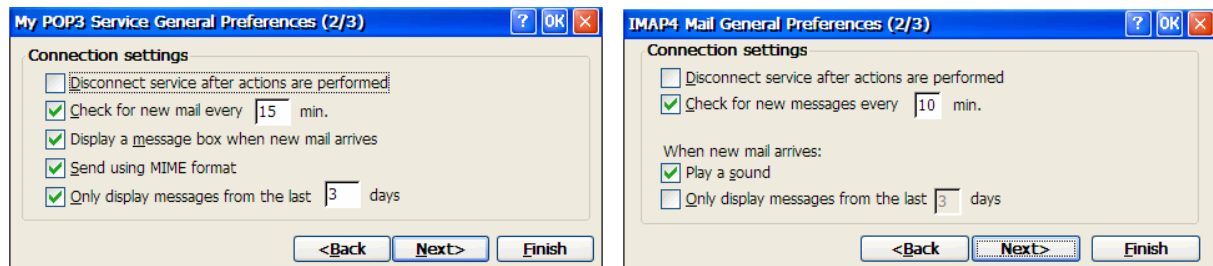

- **Disconnect service after action are performed:** Select o automatically disconnect from the server upon completion of all pending actions. This option minimizes connection time and costs.
- **Check for new mail every ?? min.:** Check this option and enter the time interval that you want the e-mail client to wait before checking to see if new mail is available. If this option is not active, you will have to manually initiate the **Send/Receive** operation to receive and/or send messages.
- **Display a message box when new mail arrives:** (POP3 only) Check this option to have a message pop up when mail arrives.
- **Send using MIME format:** Check this option if MIME format is required.
- **Play a sound:** (IMAP4 only) Check this option to be notified when messages are received.
- **Only display messages from the last ? days:** Check this option and select the number of days to display message entries for.

Click the **Next>** button to continue.

10. On the Inbox Preferences screen, select the following. Click **Finish** when done.

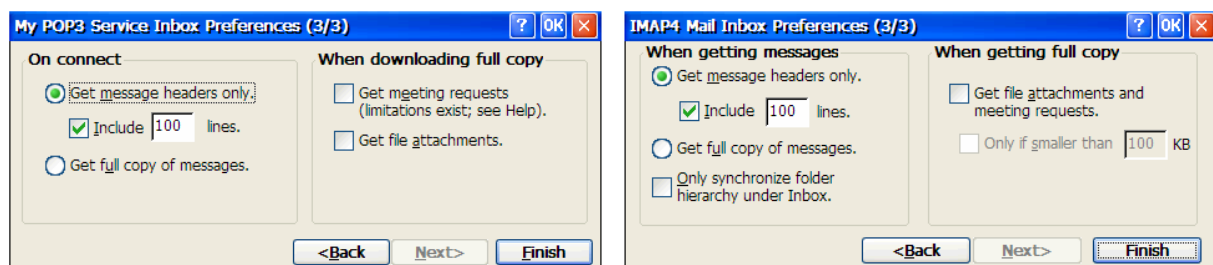

- **Get message headers only:** Select this option to have only the titles of the messages downloaded from the e-mail server. This will save time and storage space. When viewing a specific message, there will be an option to download the complete message.
- **Include ??? lines:** Check this option and enter message length to be downloaded.
- **Get full copy of messages:** Select this option to have the complete message downloaded from the e-mail server.

- **Only synchronize folder hierarch under Inbox:** (IMAP4 only) This option will speed download time by downloading only the folder list every time you connect.
 - **Get meeting requests:** (POP3 only) Select this option to download and store copies of meeting requests when receiving full copies of messages.
 - **Get file attachments:** (POP3 only) Select this option to download and save message attachments when the full copy of the message is being received. This option could use significant amounts of the thin client's RAM and will slow download times. An optional USB storage device can be used as the storage location for the attachments.
 - **Get file attachments and meeting requests:** (IMAP4 only) Select this option to download and store meeting requests when receiving full copies of messages.
 - **Only if smaller than:** (IMAP4 only) Select this option to restrict the size of attachments you download.
11. Click **Finish**> after making the desired configuration selections. The Options Screen will be redisplayed and will contain the entry for the e-mail service just configured.
 12. Select the **Compose** tab. Configure the following composition options:

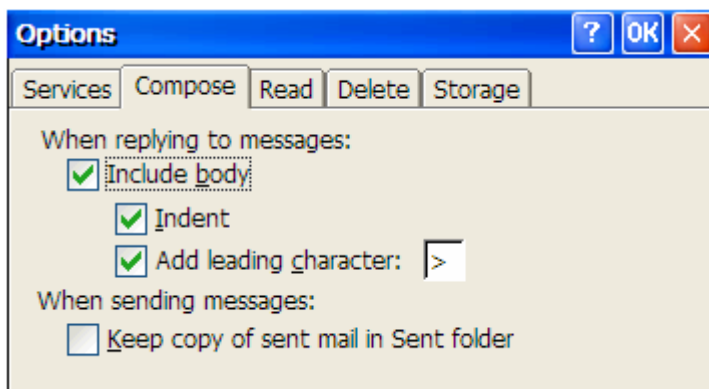

- **Include replying to messages:** Select this option to enable or disable the indent and leading character options.
 - **Indent:** Selecting this option causes the message to be indented.
 - **Add leading character:** Selecting this option allows a leading character to be placed before the original message. Click in the character field and type a character on the keyboard to be used as the leading character.
 - **Keep copy of sent mail in Sent folder:** Selecting this option will keep a copy of every message sent. This option will use RAM for storage unless USB storage has been activated in the Control Panel and the USB device has been defined in the Storage tab.
13. Select the **Read** tab. Configure the following options to establish the default actions when reading messages.

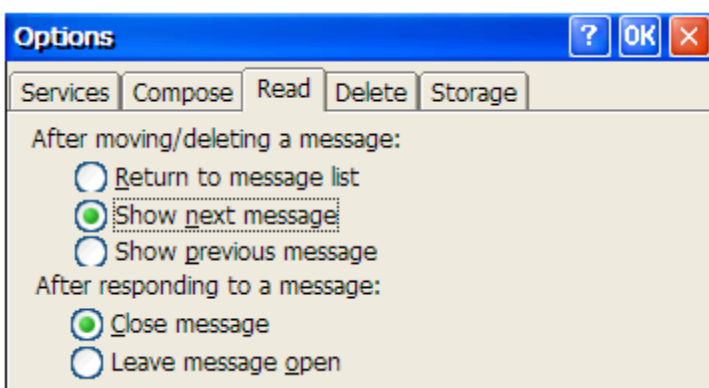

- **Return to message list:** Selecting this option will cause the message list to be redisplay after moving or delete a message.
 - **Show next message:** Selecting this option will cause the next message in the list to be displayed when the current message is deleted.
 - **Show previous message:** Selecting this option will cause the previous message to be displayed.
 - **Close message:** Selecting this option will cause the message to close after replying to the message.
 - **Leave message open:** selecting this option will cause the message to remain display after you have replied to the message.
14. Select the **Delete** tab. Determine how deleted messages are to be handled.

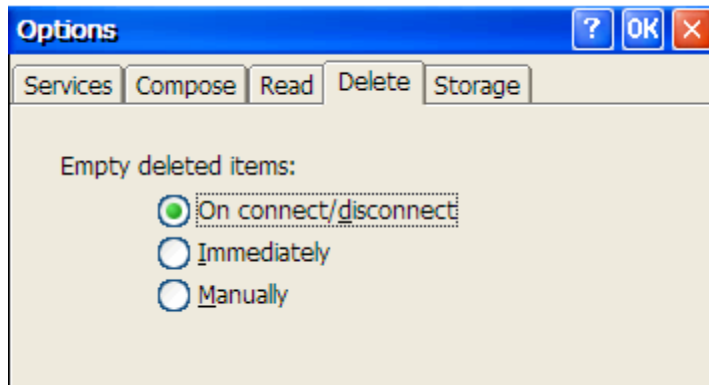

- **On connect/disconnect:** Select this option to have items marked for deletion (in the Delete folder) removed when a connection or disconnection occurs.
 - **Immediately:** Select this option to cause items to be deleted at the time the delete function is taken.
 - **Manually:** Select this option to cause the items to be retained until you manually delete them.
15. Select the **Storage** tab. Determine whether to store attachments in RAM or on an USB storage device.

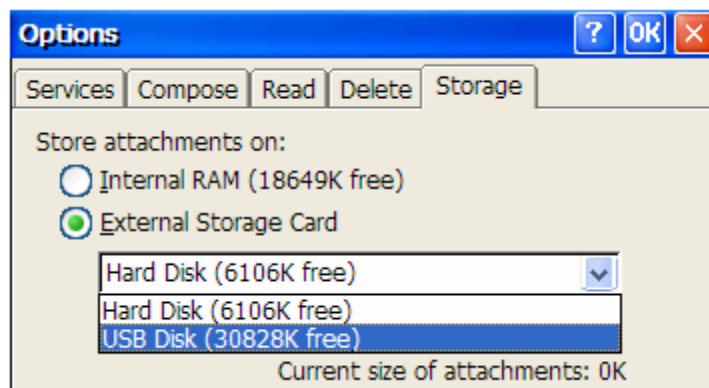

- **Internal RAM:** Selecting this option will cause mail attachments to be stored in the RAM of the thin client.
- **External Storage Card:** Selecting this option will allow mail attachments to be stored on an USB storage device.

If an external storage card option is selected, you will need to name directory for storage of the attachments.

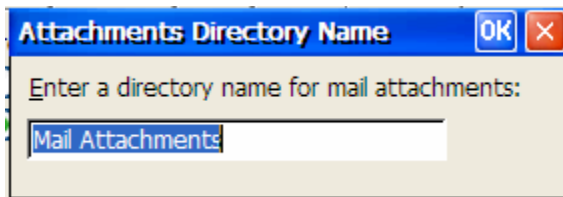

NOTE: STORING ATTACHMENTS IN THE INTERNAL RAM OF THE THIN CLIENT WILL USE UP VALUABLE RAM USED FOR THE SYSTEM OPERATION. IT IS SUGGESTED THAT IF ATTACHMENTS ARE TO BE KEPT, THAT AN USB STORAGE DEVICE BE USED.



TIP: THE USB STORAGE DEVICE IS ACTIVATED IN THE CONTROL PANEL.

Click OK after all configuration options have been selected. The main e-mail screen will be redisplayed.

Using Connections

I-O 5250 Printing

Start the I-O 5250 Printer Session

When you start an I-O 5250 Printer connection, a Control Panel is displayed. This screen shows the status of the IBM host connection and printer attached to the thin client. Printer control functions like ejecting a page, printing a configuration report, canceling a printer job are executed using control buttons.



NOTE: MORE DETAILED INFORMATION ABOUT THE USE OF THE I-O 5250 PRINTER EMULATION IS PROVIDED IN THE **TN5250e Printer Emulation User's Guide**. THIS GUIDE IS LOCATED ON THE CD SUPPLIED WITH THE THIN CLIENT. IT MAY ALSO BE ACCESSED FROM THE CONFIGURATION UTILITY'S HELP MENU.

Other Control Panel options affecting the printer and print job are described in the Customizing the I-O 5250 Printer Session chapter.

To start an I-O 5250 Printer session, follow these steps:

1. Click on the Connections Tab.

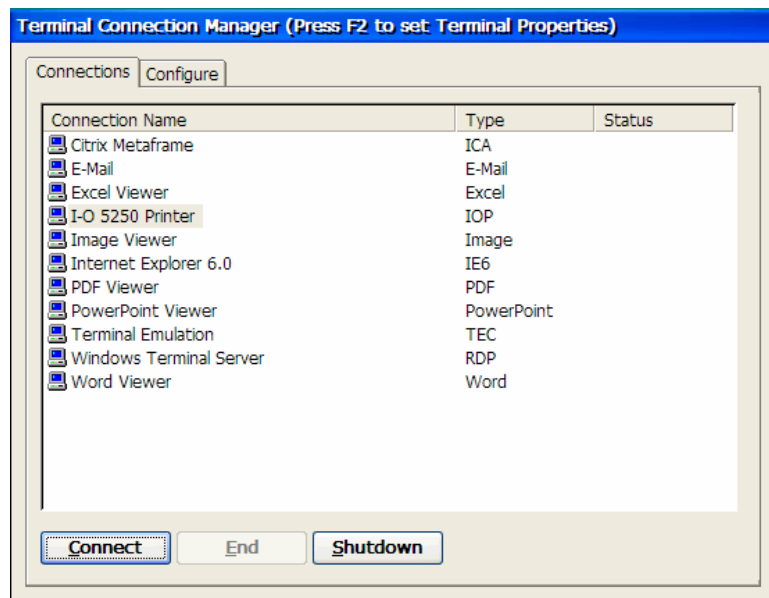

2. Click on the **I-O 5250 Printer** entry.



NOTE: PRIOR TO STARTING A PRINTER SESSION, MAKE SURE THE PRINTER IS ATTACHED TO THE APPROPRIATE LPT1, COM1 OR USB PORT, IS POWERED ON, AND YOU HAVE COMPLETED THE CONFIGURATION OF THE I-O 5250 PRINTER CONNECTION.

3. Click on the **Connect** button.



TIP: TO QUICKLY ACTIVATE A CONNECTION, YOU MAY DOUBLE-CLICK ON THE I-O 5250 PRINTER CONNECTION ENTRY IN LIEU OF STEPS 2 AND 3 ABOVE.

4. The following I-O 5250 Printer Control Panel will appear. From this control panel you can test the printer connection, cancel host jobs that are currently printing, and change the way in which host print jobs are handled, and end the printer session.

I-O 5250 PRINTER CONTROL PANEL

FormFeed	Override Host Format	No
Cancel Job	Auto Print Orientation	Enabled
Printer Test	Paper Size	Host
End Session	Orientation	Host
	End of Line Control	Wrap
	Diagnostic Dump	Disabled
Host Status	Printer Status	Host Device Name
System Available	Printer Idle	Print01

- **Host Status:** This field will initially display the message “Waiting for System”. After a few seconds, the Host Status field will display “System Available” indicating that the IBM host printer connection is active. (Be patient, it may take a few seconds for the IBM host to complete the connection).
- **Printer Status:** This field will display “Printer Idle” indicating that the attached printer is ready.
- **Host Device Name:** This field will display the name of this printer connection as it appears on the IBM host.

Once the Host Status field displays “System Available”, the I-O 5250 Printer connection is now ready to accept printer jobs from the IBM host. On the IBM host, SCS print jobs are sent to this printer connection by directing the print job to the printer device that has been defined with the Host Device Name as shown above. All normal IBM host printer control functions are available from the host (spooling, restarting, range printing, error status messaging, etc.)

It may be necessary or the user may desire to change the configuration of one or all print jobs. This can be done in two ways: 1) use the Control Panel options, or 2) using I-O’s Host Download Commands. These are described in detail in the Customizing the I-O 5250 Printer Session chapter in the TN5250e Printer Emulation User’s Guide.



NOTE: TO SWITCH BACK TO THE CONNECTION MANAGER SCREEN, PRESS CTRL+ALT+END. TO ROTATE THROUGH ACTIVE CONNECTIONS, PRESS CTRL+ALT+DOWNARROW.

5. To end the printer session, click the **End Session** button.

Test the Printer Attached to the Thin Client

To verify the printer attached to the thin client is communicating properly with the I-O 5250 Printer Connection, click on the Printer Test button. A two page configuration report will then be printed. (See Appendix C for an example configuration report.)



NOTE: ON THE CONFIGURATION REPORT, THE SYMBOL SET VALUES AND CONFIGURATION PARAMETERS WILL DIFFER FROM THE REPORT THAT YOU WILL RECEIVE. THIS IS INCLUDED HERE ONLY AS AN EXAMPLE OF THE TYPE OF CONFIGURATION REPORT YOU WILL RECEIVE.)

Eject a Page from the Printer

Sometimes data to be printed is sent to a laser printer, but the printer does not eject the page. Pressing the **FormFeed** button will cause the printer to eject the page.

The **FormFeed** button may also be used to advance the paper to the top of the next page for a dot-matrix printer.

Cancel the Print Job

To cancel the current job that is printing, press the Cancel Job button

End the I-O 5250 Printer Session

To end the I-O 5250 Printer session, click the End Session button. If you have made any changes to the control panel options, a message screen will ask if you want to save the changes.

If any configuration changes have been made using either the Control Panel options or through sending Host Download commands from the IBM host, a message screen will be presented when the End Session button has been pressed.

- **Yes:** Select Yes if you want the changes to be saved so they will be there when you restart the printer connection.
- **No:** Select No to discard the changes.



TIP: REFER TO THE CUSTOMIZING THE I-O 5250 PRINTER SESSION CHAPTER IN THE TN5250E PRINTER EMULATION USER'S GUIDE FOR A DETAILED DESCRIPTION OF THE USE OF HOST DOWNLOAD COMMANDS.

I-O 5250 Printer Control Panel Options

These options can be changed at any time and as many times as desired during a 5250 printer session. When you end the I-O 5250 Printer session, a message screen will ask if you want to save the changes. When you restart the printer connection, the previously saved options will be active.



TIP: SIMILAR COMMANDS ARE ALSO AVAILABLE AS HOST DOWNLOAD COMMANDS THAT ARE SENT FROM THE IBM HOST TO THIS I-O 5250 PRINTER EMULATION SESSION.



NOTE: COMPLETE INSTRUCTIONS FOR CONFIGURING AND USING THE THIN CLIENT AND IBM HOST TO USE THE I-O 5250 PRINTING MODULE ARE INCLUDED IN THE TN5250E PRINTER EMULATION USER'S GUIDE.

Terminal Emulation

To use a terminal emulation session:

1. On the Connections tab in the Connections Manager, **double-click** a terminal emulation connection name (has TEC in the Type column), or click a connection name and then click **Connect**.

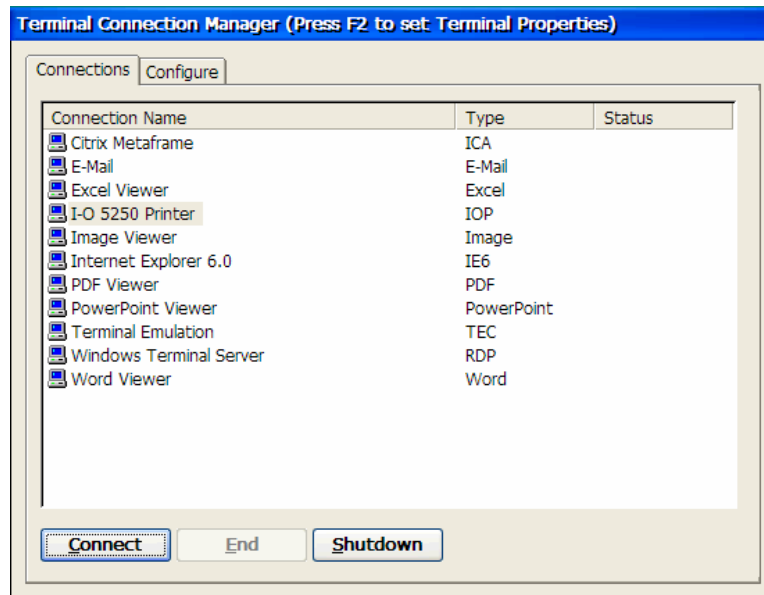

2. If the login for this connection has not been automated, enter the appropriate user name and password.
3. Enter appropriate data, etc. for the host application being used.
4. To close the connection, click **File | Exit**. You may also click the close button (the X in upper right corner) on the command bar.



NOTE:: MORE DETAILED INFORMATION ABOUT THE USE OF TERMINAL EMULATION CONNECTIONS IS PROVIDED IN THE **Terminal Emulation User's Guide**. THIS GUIDE IS LOCATED ON THE CD SUPPLIED WITH THE THIN CLIENT.

RDP Connection to Windows Terminal Servers

To use a RDP connection to a Windows terminal server:

1. On the Connections tab in the Connections Manager, **double-click** a RDP connection name (has RDP in the Type column), or click a connection name and then click **Connect**.

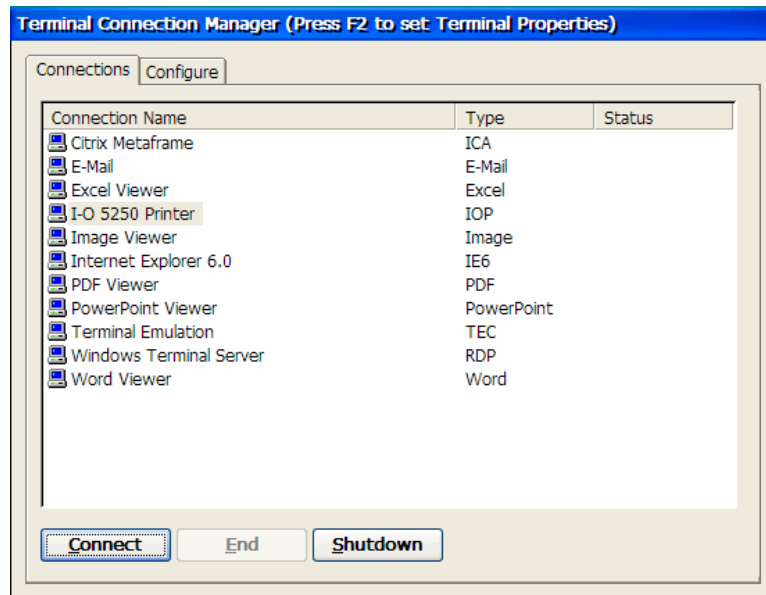

2. If the login for this connection has not been automated, enter the appropriate user name and password.
3. Run Windows applications as needed.
4. To close the connection, click **File | Exit**. You may also click the close button (the X in upper right corner) on the command bar.



NOTE:: REFER TO YOUR MCSE AND MICROSOFT DOCUMENTATION ON THE USE OF TERMINAL SERVICES..

ICA Connection to Citrix Servers

To use an ICA connection to a Citrix server:

1. On the Connections tab in the Connections Manager, **double-click** an ICA connection name (has ICA in the Type column), or click a connection name and then click **Connect**.

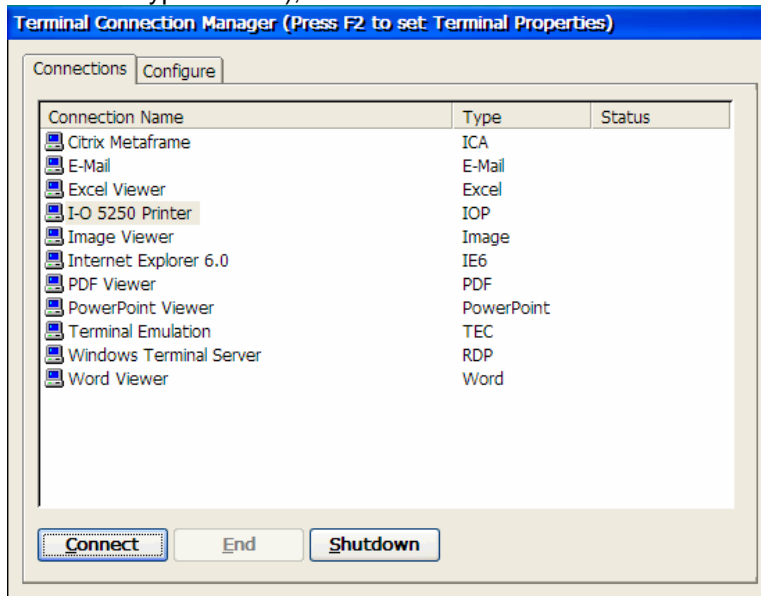

2. If the login for this connection has not been automated, enter the appropriate user name and password.
3. Run the appropriate applications as needed.
4. To close the connection, click File | Exit. You may also click the close button (the X in upper right corner) on the command bar.



NOTE:: MORE DETAILED INFORMATION ABOUT THE USE OF ICA CONNECTIONS IS PROVIDED IN THE **CITRIX ICA CLIENT FOR WINDOWS CE WINDOWS-BASED TERMINALS ADMINISTRATOR'S GUIDE**. THIS GUIDE IS LOCATED ON THE CD SUPPLIED WITH THE THIN CLIENT. IT MAY ALSO BE ACCESSED FROM THE CONFIGURATION UTILITY'S HELP MENU.

REFER TO YOUR CITRIX CERTIFIED ADMINISTRATOR FOR ASSISTANCE IN THE CONFIGURATION AND USE OF THE ICA CLIENT AND OTHER CITRIX PRODUCTS.

Microsoft Viewers

Viewers for documents created by Microsoft's Word, Excel, PowerPoint as well as standard image files, and PDF files can be viewed on the thin client.

If the document is accessed through the thin client's Internet Explorer browser or e-mail client, the appropriate viewer will open.

For documents that are stored on a USB storage device or are located on a shared network drive and accessed through a RDP or ICA connection, a viewer connection must be used (refer to **Creating Connections**). Once a viewer connection is setup, it is a simple matter of navigating to the document's location to view the document.

Running the Viewer

1. On the Connections tab in the Connections Manager, **double-click** the desired viewer connection, or click the connection name and then click **Connect**.

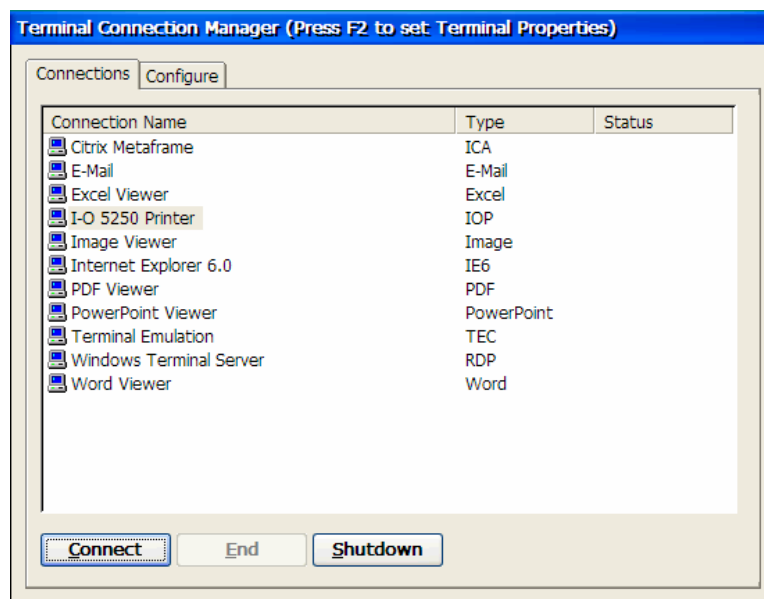

2. Click **File | Open**, and navigate to the location where the document is stored.
3. Viewing options are available from the View menu.
4. On some of the viewers, the Settings menu will provide additional setup parameters that can be customized.
5. The Image and PowerPoint viewers also include a slide show option.
6. To close the viewer connection, click **File | Close**, or double click the "X" in the upper corner of the screen.

Printing from a Viewer

Viewer documents can be printed to a locally attached PCL laser printer.

1. Click **File | Print**, and the following screen appears.

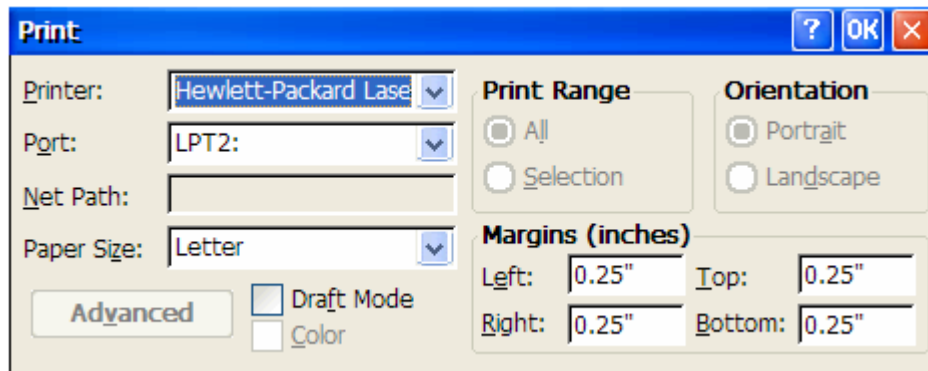

- **Printer:** Microsoft only supplies a driver for HP LaserJet or PCL compatible printers.
- **Port:** From the drop down list, select the port that the printer is attached. For the USB port, select LPT2. (Microsoft considers the USB port as LPT2 for printing purposes.) Selecting Network will allow you to print via NetBIOS to a printer attached to a Windows PC or printer that has been setup for NetBIOS printing.
- **Net Path:** Enter the complete NetBios path name, such as \\IR600-550-50\Print.
- **Paper Size:** Select the appropriate size of paper.
- **Draft Mode:** Check this box to cause the printer to print in draft mode.
- **Margins:** Enter the desired margins.
- **Print Range:** Select the range to print.
- **Orientation:** Select the orientation of the page.
- **Advanced:** Presents a collection of advanced printing options.
- **Color:** Enables color printing if supported by the printer.



NOTE: NOT ALL OPTIONS MAY BE AVAILABLE IN A GIVEN VIEWER. FOR EXAMPLE MARGINS ARE ONLY AVAILABLE WHEN PRINTING FROM AN INTERNET EXPLORER CONNECTION.

2. Click **OK** after all selections are made and you are ready to print. A progress message will popup showing what page is currently being printed. You may also cancel the remainder of the print job from this status message popup.

Limitations of the Microsoft Viewers

The file viewers provide users with a way to read common Microsoft® Office® file types as well as PDF files. The Microsoft file viewers in Windows CE .NET do not provide all of the features that are available in their corresponding Windows desktop applications. Typically these limitations result in a different document layout or presentation; however, in some cases, document content may not be visible.

- There is no support for files created in versions of Microsoft Office earlier than Office 97.
- The Microsoft Visual Basic® macro programming language is not supported.
- Windows CE .NET does not provide the same set of fonts that is available on Windows-based desktop platforms. If the original font is not available, the Windows CE .NET file viewers show the closest possible approximation of the original format.
- If sufficient memory for temporary file storage is not available on a device, very large documents or documents that contain large graphical elements may not open, or may not display all of the content.
- File viewers do not use ClearType.

Font recommendations

The Microsoft file viewers map missing fonts to those that are installed on the available system. The following list shows fonts that you should include in your platform for optimal performance with the Microsoft Office viewers and the Microsoft PDF viewer:

- Arial
- Arial Italic
- Times New Roman
- Times New Roman Italic
- Courier New
- Symbol
- Wingding

In addition, you should include these fonts for the Microsoft PowerPoint® viewer:

- Impact
- Verdana
- Comic Sans MS

Microsoft Excel Viewer

The following list shows features not supported by the Microsoft Excel viewer:

- Hyperlinks.
- Data tables in charts.
- WordArt. Plain text is substituted.
- Surface charts. An image representing an unsupported chart appears in the chart's location.

The following list shows some of the additional limitations:

- Certain types of 3D charts are mapped to equivalent 2D charts.
- Supported 3D charts are only shown at a fixed camera angle.
- Vertical text in the worksheet is mapped to 90-degree rotated text.

TC5000 Printing Overview

The thin client has several methods for printing. The following is a brief overview of the various methods:

I-O TN5250e Printing – receives print jobs from the IBM host directly to a printer attached to the thin client. The printer is setup when the I-O 5250 Printing connection is added on the Connection Manager. No other printer configuration is required on the thin client. The IBM host will automatically create a printer device.

Host Print Transform Printing – receives print jobs from the IBM host to a printer attached to the thin client. The printer is setup when the Terminal Emulation printer session is added on the Connection Manager. The IBM host must have a printer created on it as well. Because of the well known problems of this type of printing (often called the “black hole of printing”) it is recommended that IBM host printing be done through the I-O TN5250e Printing connection.

LPR/LPD Printing – receives print jobs from a host or PC to a printer attached to the thin client. The printer is setup using the LPR/LPD printing option on the Control Panel. No other printer configuration is required on the thin client. The sending host or PC must have a LPR printer created and the appropriate print driver installed. The thin client is the LPD device. LPR is the sending side and LPD is the receiving side.

Local Printing (Viewer, E-mail and Internet Explorer) – prints to a PCL printer that is attached to the thin client. No other printer configuration is required on the thin client. Note: Microsoft only supports HP LaserJet or compatible PCL printers.

Network Printing (Viewer, E-mail and Internet Explorer) – prints to a PCL printer that is attached to another Windows PC, or a NetBIOS capable printer. No other printer configuration is required on the thin client. Note: Microsoft only supports HP LaserJet or compatible PCL printers.

RDP Printing, Method 1 – prints from applications running on a Microsoft Terminal Server. Printers are created on the thin client using the Add Printer option on the Control Panel. When a connection is made to a terminal server, the terminal server copies the printer objects to the terminal server. The user then can select from those printers when they are running an application on the terminal server.

RDP Printing, Method 2 – also prints from applications run on a Microsoft Terminal Server. However, printers are created on the terminal server in lieu of the thin client.

ICA Printing – prints from applications run on a Citrix Metaframe server. Printers are configured on the Citrix server.

Windows Media Player

The Windows Media Player V9 acts as a universal player for rendering most standard multimedia formats. This includes stored and live content in network audio and video formats. Multimedia file formats and codecs supported by this version of the Windows Media Player control include the following:

Audio streaming formats

- Moving Picture Experts Group standard 1, Layer 1,2, 3 (.mpa, .mp2, .mp3)
- Windows Media Audio (.wma)

Video streaming formats

- Moving Picture Experts Group standard 1 (.mpg, .mpeg, .mpv, .mpe)
- Advanced Streaming Format (.asf)
- Windows Media Video Format (.wmv)
- Advanced Stream Redirector (.asx)
- Windows Media Audio Redirector (.wax)
- Windows Media Video Redirector (.wvx)
- Windows Media Redirector (.wmx)

Non-streaming (local playback) audio formats

- Waveform Audio (.wav)
- Sound File (.snd)
- UNIX audio (.au)
- Audio Interchange File Format (.aif, .aiff, .aifc)

Non-streaming (local playback) video formats

- Audio-Video Interleaved (.avi)
- Audio Codecs
- Microsoft Pulse Code Modulation (PCM)
- Microsoft GSM 6.10 Audio (GSM 610)
- Microsoft CCITT G.711 A-Law and u-Law
- Microsoft Adaptive Differential Pulse Code Modulation (MS ADPCM)
- Interactive Multimedia Association Adaptive Differential Pulse Code Modulation (IMA ADPCM)
- Microsoft MPEG-1 Layer 1; Microsoft MPEG-1 Layer 2
- Windows Media Audio (WMA) v2, v7, v8, v9 (including Windows Media Audio 9 Voice)
- Fraunhofer MPEG-1 Layer 3 (MP3)

Video Codecs

- Microsoft MPEG-1 (MS MPEG-1)
- Microsoft RLE8
- Microsoft MPEG-4 v2, v3, ISO v1
- Windows Media Video (WMV) v7, v8, v9 (including Windows Media Video 9 Image)

- Windows Media Video supports the following output formats on the primary GDI surface: PAL1, PAL2, PAL4, PAL8, xRGB1555, RGB565, RGB24, BGR24, and xRGB8888 (ARGB8888).
- Windows Media Video supports the following YUV formats for overlay surfaces: YUYV, YUV422 (YUY2), and YV12 (Planar YUV).

E-mail

Microsoft's E-mail client provides you with the ability to send and receive e-mail via POP3 or IMAP4 servers, view and print attachments, save attachments either locally within the thin client in RAM or on an external USB storage device.

To use the E-mail client, the client must first be added as a connection. Next, the basic e-mail configuration parameters must be setup. After the client is configured, then you may use the client for e-mail functions.

If the e-mail client has not been setup, refer to the Creating Connections chapter.

Configuring the E-mail Client

1. On the Connections tab in the Connections Manager, **double-click** the E-Mail connection, or click the E-Mail connection name to highlight it and then click **Connect**.

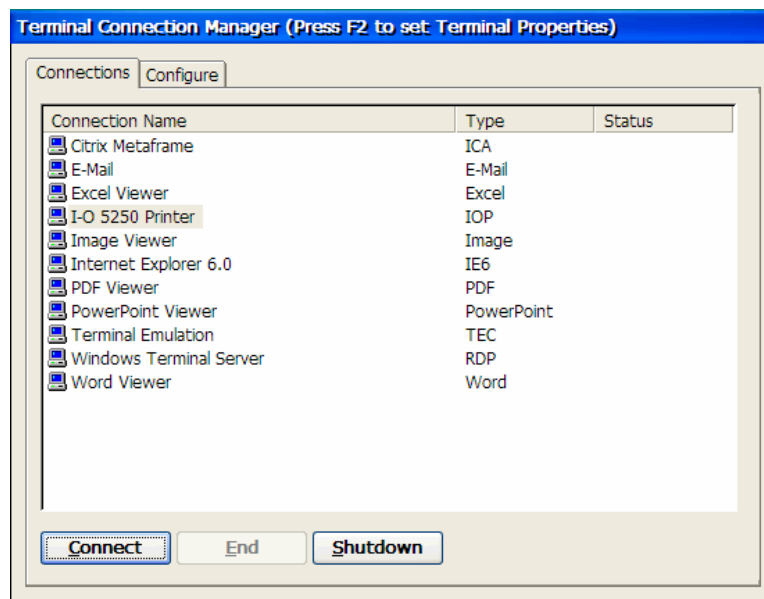

2. The E-mail main screen will appear. On this screen will be the folders for incoming mail, out going , sent and deleted mail. Additional folders can be created as needed. In the larger portion of the screen can be found the listing of e-mails in each folder. Menus allow access to the various functions for sending, deleting, moving e-mails as well as setting up the configuration options. Icons are available for creating, replying e-mail, forwarding and deleting an e-mail. Other Icons include connecting to the e-mail server, receiving and sending already composed e-mails, and accessing the address book.

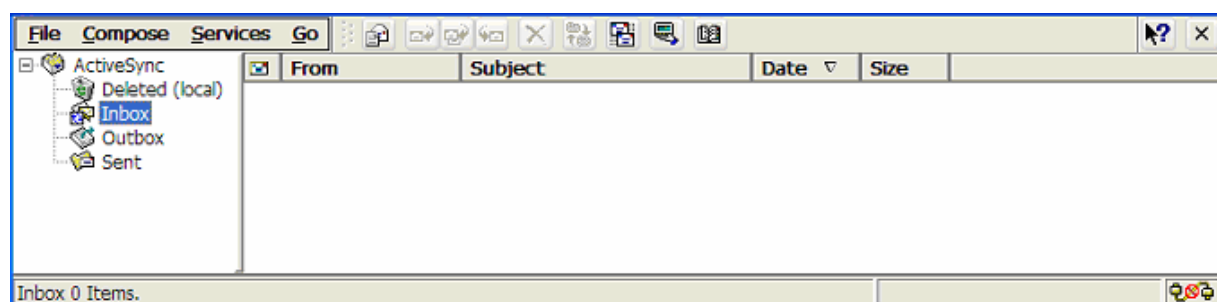

3. To setup the basic e-mail connection options, click **Services | Options**, and the Options screen will be displayed.

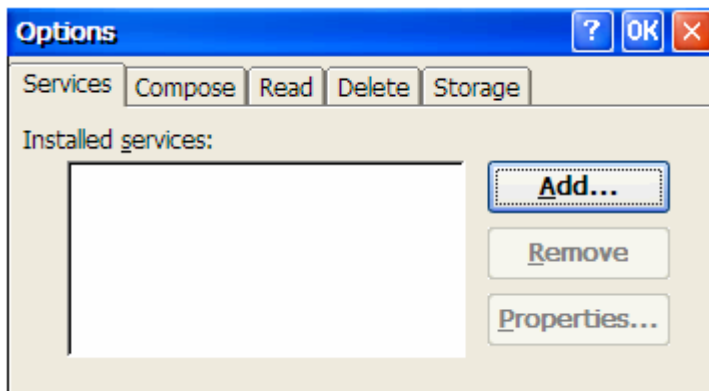

4. Click the **Add** button. The Service Name screen will appear.

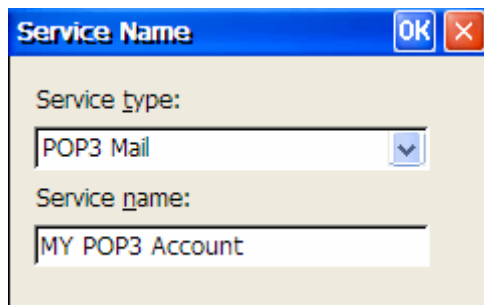

- **Service Type:** Select either POP3 or IMAP4 depending upon your e-mail server type.
- **Service Name:** Enter a unique name for this mail server.

Click **OK** to continue.

5. On the Service Definition screen, complete the following. Then click **Next>** to continue.

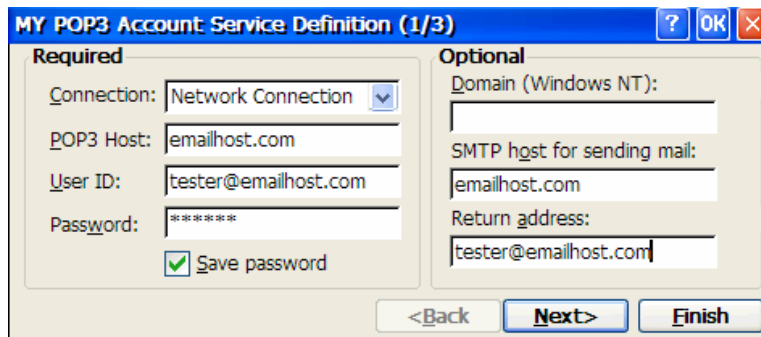

- **Connection:** Select **Network Connection** from the drop down list. Other types of connections are not supported for e-mail.
- **POP3 Host:** Enter the name of your e-mail server.
- **User ID:** Enter your e-mail username.
- **Password:** Enter the password for your e-mail account. If you do not enter the password, each time you connect to the e-mail server, you will be prompted to enter the password.
- **Save Password:** Check this box to have your password remembered so that you will not be asked for it each time you connect to the e-mail server.
- **Domain:** If you are connecting to a network that uses Windows NT domain security, enter the Windows NT domain name here. Generally most ISP based e-mail servers do not require this.
- **SMTP Host for sending mail:** If your e-mail service uses a separate server for SMTP, enter the name in this field. POP3 services use this field.
- **Return Address:** Enter the desired return to e-mail address in this field.

Click **Next>** to continue.

6. On the General Preferences screen, complete the following. Then click **Next>** to continue.

- **Disconnect service...:** Check this option to automatically disconnect from the server upon completion of all pending actions. This option most effectively utilizes connection time and bandwidth.
- **Check for new mail...:** Check this option to have the thin client check for new mail periodically. Enter the desired amount of time to wait until the e-mail server is checked for new mail.
- **Display a message box...:** (POP3 option) Check this option to be informed when new mail is received.
- **Play a sound:** (IMAP4 option) Check this option to be informed when new mail is received.
- **Send using...:** (POP3 option) Check this option to send mail using the MIME format (messages are sent with extended characters).
- **Only display messages...:** Check this option if you want to specify the number of days in the past that will be downloaded when a connection is made to the e-mail server. Messages on the e-mail server older than this selection will not be downloaded.

Click **Next>** to continue.

7. On the Inbox Preferences screen, complete the following. . Then click **Next>** to continue.

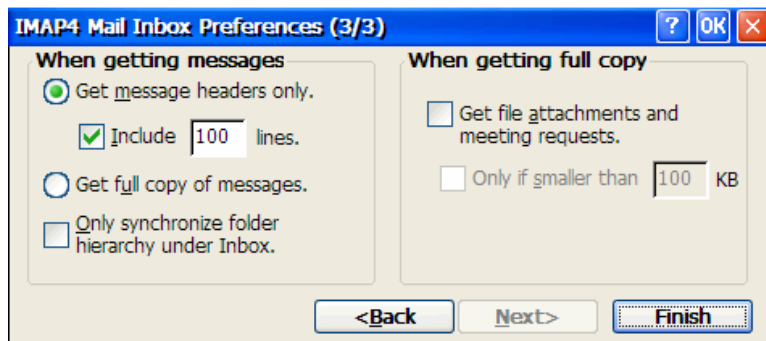

- **Get message headers only:** Select this option to save storage space and time. Only the message header will be downloaded. The full message may be later by selecting the message, then **Services | Get Full Copy**.
- **Include ??? lines:** Select the number of message headers to download.
- **Get full copy of messages:** Select this option to download the complete message. This will increase the amount of storage space used in the thin client and time to download the message.
- **Get meeting requests:** (POP3 option) Check this option to have copies of meeting requests downloaded when the full copy of the message is downloaded.
- **Only synchronize folder...:** (IMAP4 option) Select to speed the download time by preventing the complete download of the folder list every time a connection is made.
- **Get file attachments:** Check this option to have all attachments to messages downloaded when the full message is downloaded. This option will also use storage space. If the USB storage option has been selected in the Control Panel, then attachments will be stored in the external USB device.
- **Get file attachments and meeting requests:** (IMAP4 option) Check this option to download and store meeting requests and message attachments when getting full copies of messages.
- **Only if smaller than:** (IMAP4 option) Check this option to restrict the size of the attachments downloaded. Setting 10K will limit the downloads to meeting requests only.

Click **Finish** when complete.

Remove a Service

E-mail services can be removed when no longer valid.

1. From the E-mail screen click **Services | Options**, and the Options screen will be displayed.

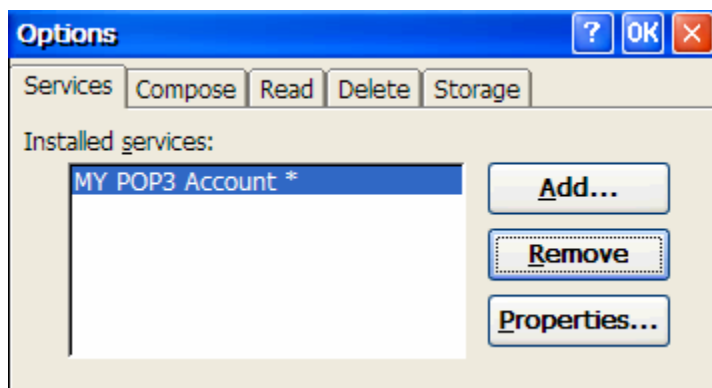

2. Click the **Remove** button, and the following message will be displayed:

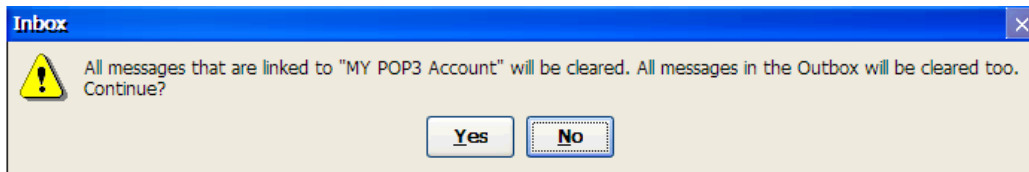

3. Click **Yes** to remove the service.

Edit a Service

Changes may be made to an e-mail service.

1. From the E-mail screen click **Services | Options**, and the Options screen will be displayed.

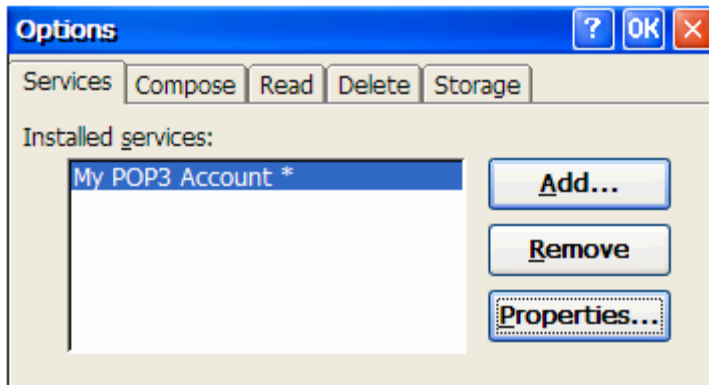

2. Click the **Properties...** button. The same screens are presented that are used in adding a service (refer to Configuring the E-mail Client).

E-Mail Overview

Each time that the e-mail client is started, the default Message List screen will be presented. From this screen, you create and send messages, received and read messages, store messages in folders and delete unwanted messages.

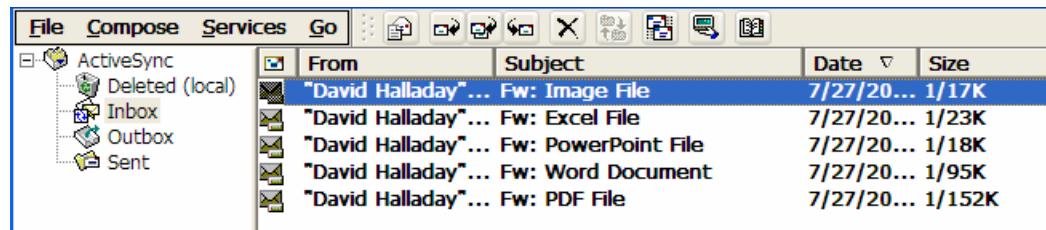

File Menu

The following operations are available from the File Menu:

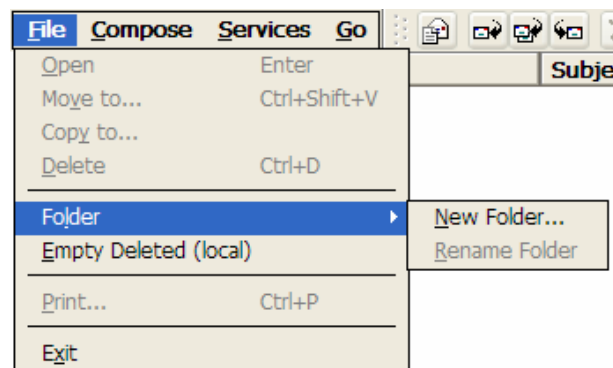

- **Open:** The highlighted message will be opened.
- **Move to:** The highlighted message will be moved to a different folder.
- **Copy to:** The highlighted message will be copied to another folder.
- **Delete:** The highlighted message or folder will be removed from the current folder and moved to the Deleted (local) folder. The message will be deleted according to the setup options taken on the Services | Options | Delete tab.
- **Folder | New Folder:** Creates a new folder.
- **Folder | Rename Folder:** The highlighted folder is renamed.
- **Empty Deleted (local):** The messages stored in the deleted folder are immediately deleted.
- **Print:** The highlighted message may be printed. The thin client local print dialog box will be presented when this option is taken.
- **Exit:** Closes the e-mail client. The "X" in the upper right corner (on the menu/tool bar) also closes the client.

Compose Menu

New messages may be created here as well as replying to and forwarding messages.

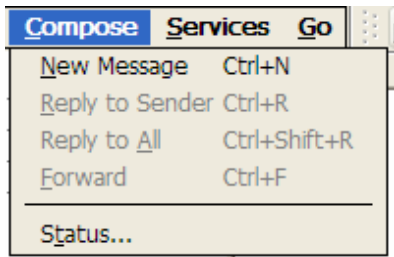

- **New Message:** Opens the Compose Message screen.
- **Reply to Sender:** Opens the Compose Message screen and attaches the current message if the option is set on the Services | Options | Compose tab. The message is automatically addressed to the sender.
- **Reply to All:** Opens the Compose Message screen and attaches the current message if the option is set on the Services | Options | Compose tab. The message is automatically addressed to not only the sender, but also to those who received a copy of the original message.
- **Forward:** Opens the Compose Message screen and attaches the current message if the option is set on the Services | Options | Compose tab. You will need to enter the e-mail address to forward the message to.
- **Status:** Provides a listing of messages received, sent, etc.

Services Menu

The Services Menu allows you to connect and download messages from the e-mail server, to select which e-mail service is active, to synchronize folders between the e-mail server and the thin client, as well as configure the e-mail client.

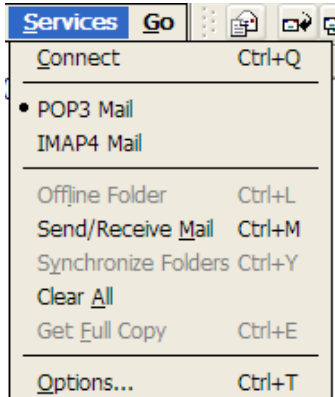

- **Connect:** Connects the e-mail server and downloads the messages according to the options selected on the Inbox Preferences screen.
- **[Service]:** This section of the menu will list the e-mail services that have been setup. The default or active service will have a bullet in front of it. To change services, just click on the service.
- **Offline Folder:** (IMAP4 only) All IMAP4 folders are automatically designated as offline. Message in offline folders can be viewed when you are disconnected from the e-mail server. If a folder is not designated as offline, you will be able to read and respond to the messages in that folder only when connected to the server. The highlighted folder will be designated as offline/online when this option is taken.
- **Send/Receive Mail:** Initiates sending and receiving of e-mail. This function allows you to manually send and receive e-mails even if the option on the General Preferences screen has been set to check for new mail every few minutes. For POP3 e-mail servers, this function synchronizes the incoming and outgoing mail folders between the thin client and the e-mail server.

- **Synchronize Folders:** Causes the contents of thin client's folders and the e-mail server's folders to be compared and updated. New mail messages are downloaded and messages in the thin client's Outbox are sent when connection is made. For IMAP4 servers, this function synchronizes the incoming and outgoing mail folders between the thin client and the e-mail server.
- **Clear All:** Causes all messages and folders to be cleared and the memory used for storing the messages is released for use again. The messages still reside on the e-mail server and will be downloaded the next time a connection is made.
- **Get Full Copy:** If the option has been set on the Inbox Preference screen to download only the message headers, this function will allow cause the full message including meeting requests and file attachments to be downloaded.

Options from Services Menu

The Options Menu allows you to create, remove and change e-mail services. In addition it allows you to access configuration options for composing new messages, reading messages, selecting deletion and storage options.

Services Tab

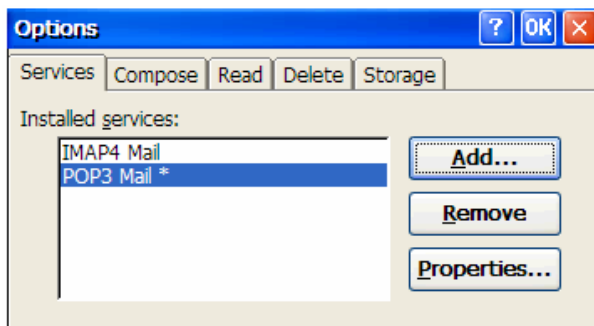

- **ADD:** Evokes the setup wizard used initially to setup the e-mail client.
- **Remove:** Deletes the highlighted service.
- **Properties:** Evokes the setup wizard used initially to setup the e-mail client.

Compose Tab

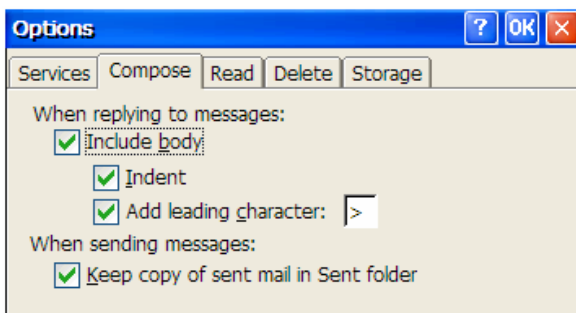

- **Include in body:** Includes the original message as a part of the replay message.
- **Indent:** Indents the original message making it easier to see.
- **Add leading character:** The selected character is placed before each line of the original message.
- **Keep copy of sent mail in Sent folder:** Places a copy of each mail sent in the Sent folder. This allows you to keep a copy of your e-mails.

Read Tab

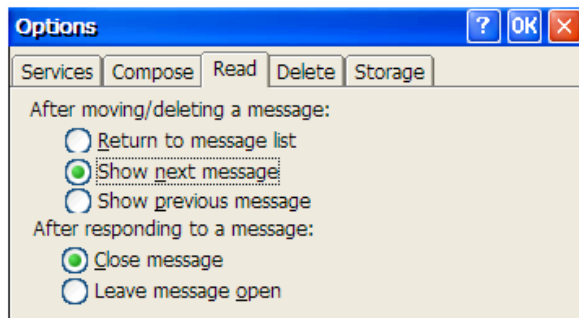

- **Return to message list:** Causes the Message List to be presented when finished with the current message.
- **Show next message:** Causes the next message to be presented when finished with the current message.
- **Show previous message:** Causes the previous message to be presented when finished with the current message.
- **Close message:** Causes the current message to be closed after responding.
- **Leave message open:** Causes the current message to be left open after responding.

Delete Tab

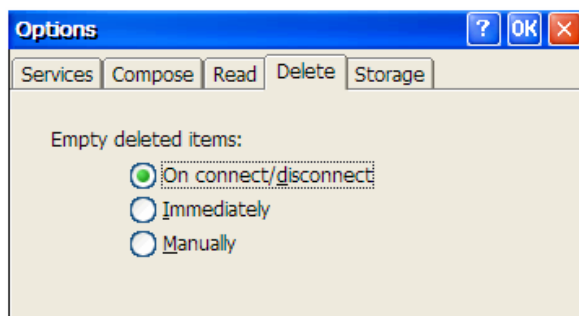

- **On connect/disconnect:** Causes the messages to be deleted when a connection is established or disconnected.
- **Immediately:** Causes messages to be deleted immediately when the delete option is taken.
- **Manually:** Messages that have been moved to the Delete (local) folder will remain in the folder until they are individually deleted.

Storage Tab

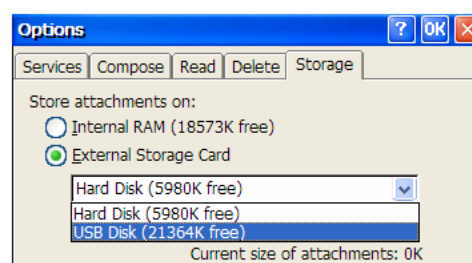
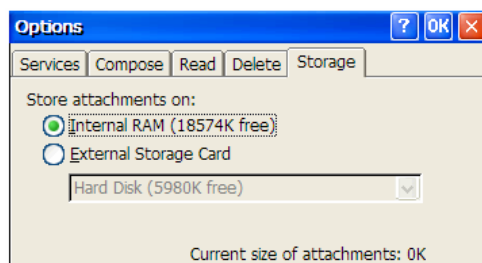

- **Internal RAM:** Mail messages and attachments are stored in the thin client's internal flash (Disk on Module). There is a limited amount of storage available – it should be managed carefully as using too much of it will limit the number of connections that can be opened.
- **External Storage Card:** This option allows the use of a plug in USB storage device. Attachments will be stored on this device freeing the thin client's flash.









Go Menu

The Go menu provides access the Address Book.

Tool Bar

The Tool Bar (located to the right of the menus) provides quick one-click access to certain menu functions.



Tool Bar Button	Description
	Create new mail message
	Reply to the current message
	Reply to all who received the current message
	Forward current message
	Delete the highlighted message
	Offline Folder (IMAP4 only)
	Send/Receive messages
	Connect to e-mail service
	Open Address Book



TIP: A BRIEF DESCRIPTION OF EACH ICON ON THE TOOL BAR WILL APPEAR WHEN THE MOUSE POINTER IS PLACED OVER THE ICON AFTER A FEW SECONDS.

Receiving Messages

Messages are received by identifying the e-mail service and initiating a download of messages. The full message, meeting request and attachments will be downloaded based upon the setup options selected while configuring the e-mail client.

Selecting the Service

Prior to downloading e-mail messages, the mail service must be selected. If only one e-mail service was setup when configuring the e-mail client, it will be used by default.

However, if more than one service has been setup (for example a POP3 and an IMAP4 service), then you will need to select which service to download messages from.

1. Select the **Services** menu. Click on the desired service. A bullet will appear by the service.

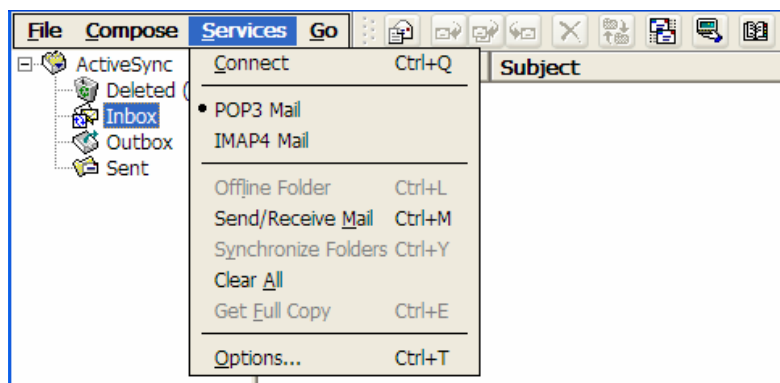

NOTE: IF ONLY ONE SERVICE WAS SETUP, BY DEFAULT, IT WILL BE AUTOMATICALLY USED (IT WILL ALREADY HAVE A BULLET BY IT.)



Downloading Messages

Downloading messages can be accomplished in one of two ways:

- Automatically if the “Check for new mail every ?? min.” option was selected on the General Preferences screen when the service was setup. The e-mail client will check for new messages every few minutes.
- Manually when desired. You will need to initiate a connection to the e-mail server. This method can also be used even though the e-mail client was setup for the automatic method.

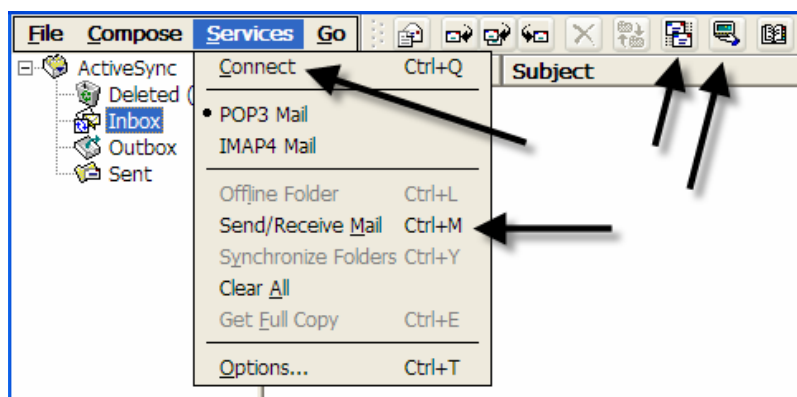
1. To download messages manually, do one of the following:



- Click the **Send/Receive** icon  on the tool bar.
- Click the **Connect** icon  on the tool bar.
- Click **Services | Connect** menu item.
- Click **Services | Send/Receive Mail** menu item.

The messages on the thin client and mail server are synchronized. New messages are downloaded to the Inbox folder, messages in the Outbox folder are sent, and messages that have been deleted on the server are removed from the thin client's Inbox.

Full Copy vs Message Header

When configuring the default settings, you are given the option to download only the header or the complete message. You may also choose to download meeting notices and attachments. Downloading only the message header consumes less internal storage than the full message, notices and attachments.

If you selected on the Inbox Preferences screen to only download the message header, you may download the full message. Select **File | Get Full Copy** while in the message window or **Services | Get Full Copy** while in list view. This will also download message attachments and meeting requests if you have those options selected in the Preferences dialog box. You can also choose to download full copies of messages by default (see the Inbox Preferences screen).

Reading Messages

To read a message:

1. **Double-click** a message in the Message List to open it.

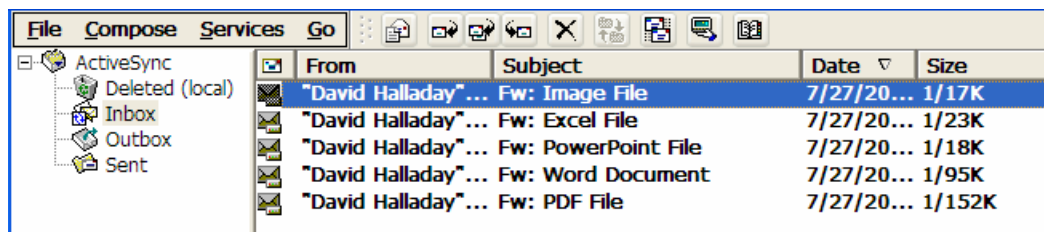

2. The message will open. On this screen, you will find four areas: The menu/tool bar, the header, the body of the message, and the attachments listing.

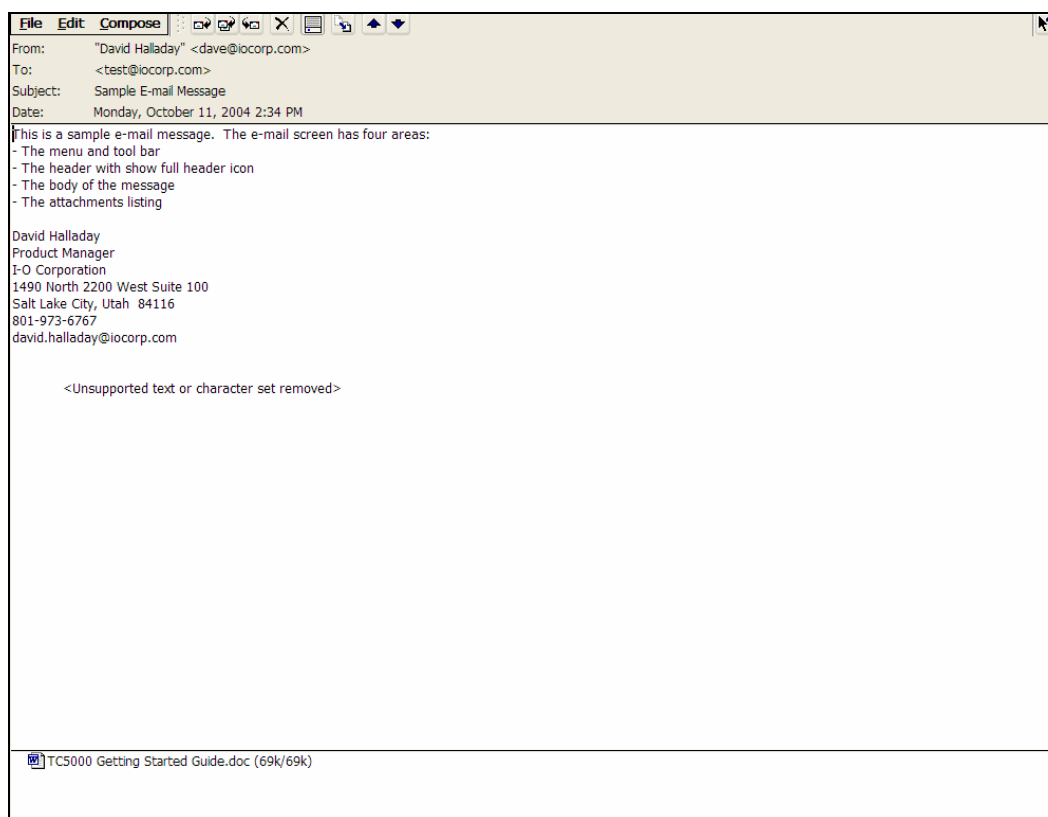

At this point, you can reply to the sender, reply to all senders, forward the message, view and save attachments, and delete the message.



TIP: TO SEE MORE HEADER INFORMATION, SELECT THE INVERTED TRIANGLE IN THE LOWER-RIGHT CORNER OF THE HEADER AREA. SELECT THE TRIANGLE AGAIN TO COLLAPSE THE HEADER AREA.



NOTE: ICONS ON THE TOOL BAR ARE AVAILABLE TO PERFORM MANY OF THE MENU OPTIONS.

Menu and Tool Bar Descriptions

File Menu

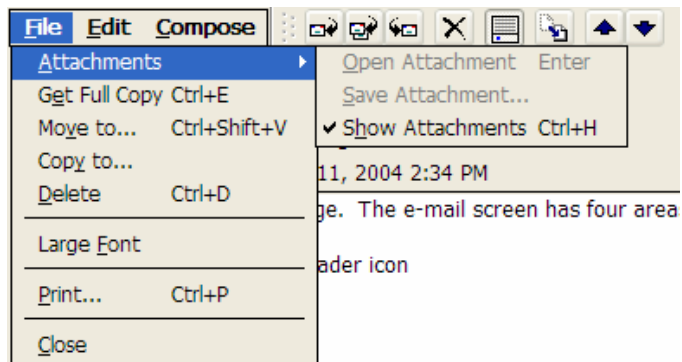

- **Open Attachments:** Select to open the attachments to the message.
- **Save Attachment:** Presents a dialog box allowing you to choose where to store the attachment.
- **Show Attachments:** Toggles on and off the display of attachments in the lower portion of the message screen.
- **Get Full Copy:** If the option has been set on the Inbox Preference screen to download only the message headers, this function will allow cause the full message including meeting requests and file attachments to be downloaded.
- **Move to:** Presents a dialog box allowing you to choose where to move the message.
- **Copy to:** Presents a dialog box allowing you to choose where to copy the message.
- **Delete:** Allows you to delete the message. Messages will be deleted according to the settings on the Options | Delete tab.
- **Large Font:** Increases the font size of the message.
- **Print:** Presents a printer dialog box for sending the message to the locally attached printer.
- **Close:** Closes the message. You may also click on the “X” button on the Menu/Tool Bar line.

Edit Menu

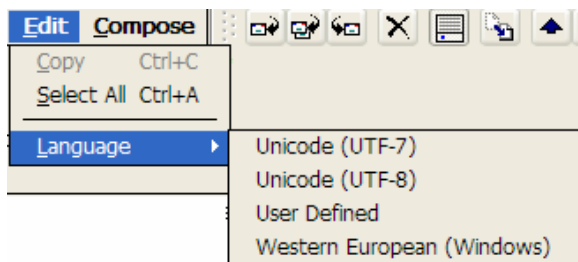

- **Copy:** Copy the selected text.
- **Select All:** Selects all text on the message.
- **Language:** Select the appropriate language for the message received. Generally this does not need to be changed from the e-mail client’s default.

Compose Menu

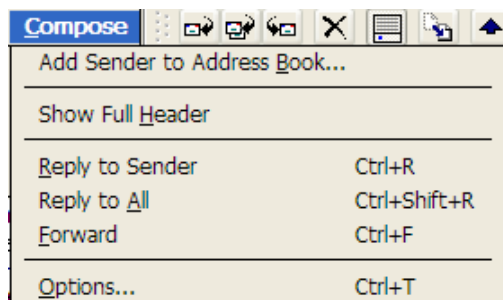







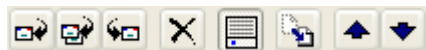

- **Add Sender to Address Book:** Provides access to the address book.
- **Show Full Header:** Expands the header to show all message header information. The down and up arrow icon on the right side of the header block can also be used to expand and collapse the header.
- **Reply to Sender:** Opens the Compose screen inserting the sender's address in the To field. The body of the message may be included depending upon the settings on the Options | Compose Tab. You may edit the message as desired.
- **Reply to All:** Opens the Compose screen inserting the addresses of the sender and all who received a copy of the message. The body of the message may be included depending upon the settings on the Options | Compose Tab. You may edit the message as desired.
- **Forward:** Opens the Compose screen allowing you to enter the appropriate addresses. You may edit the message as desired.
- **Options:** Opens the Options Dialog screens. See Options from Services Menu for description of these options.

Tool Bar Icons

The Tool Bar (located to the right of the menus) provides quick one-click access to certain menu functions.



Tool Bar Button	Description
	Create new mail message
	Reply to the current message
	Reply to all who received the current message
	Forward current message
	Delete the highlighted message
	Show listing of attachments in the Attachments block
	Get Full Copy
	Previous message
	Next message



Show full header (located in the Header block)



Collapse the header (located in the Header block)

View and/or Save an Attachment

Attachments that have been downloaded when the message is downloaded from the e-mail server will appear in the Attachments List block at the bottom of the message. If attachments are not shown, click the **File | Attachments | Show Attachments** option. If the attachment was not downloaded when the full message was downloaded, select the “Get file attachment” box on the Inbox Preferences screen (see Services | Options | Properties).

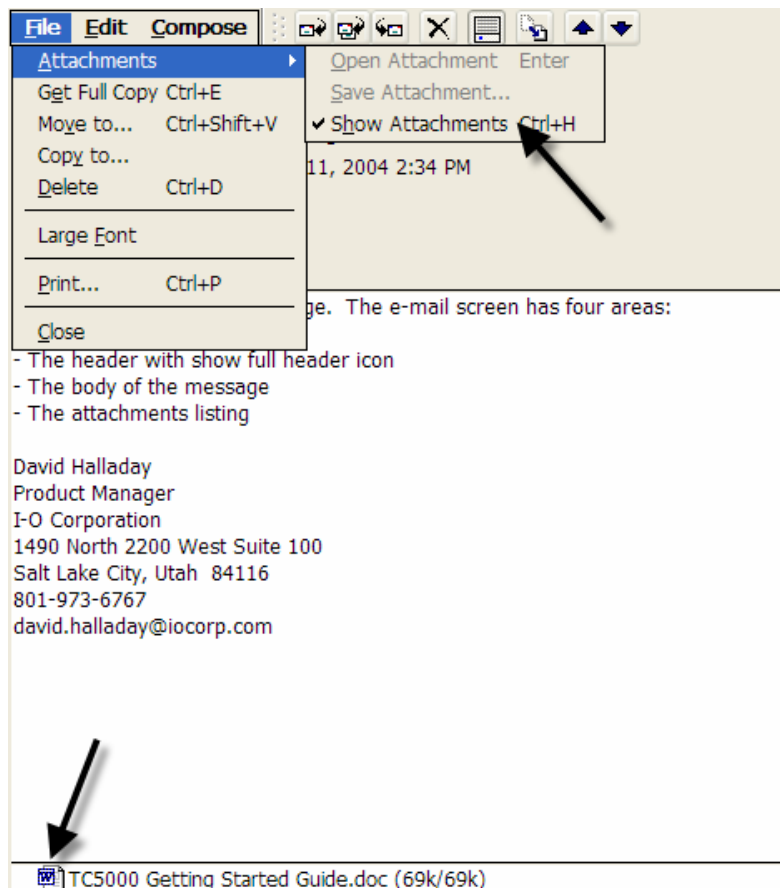

1. On the Message List screen, select a message.
2. At the bottom of the message, click on the desired attachment. The proper file viewer will load.



NOTE: VALID DOCUMENT TYPES ARE MICROSOFT WORD DOCUMENTS, POWERPOINT FILES, EXCEL SPREAD SHEETS, ACROBAT PDF FILES, AND MOST IMAGES.

3. To save the attachment, you must open the attachment first. Then close the attachment. From the **File | Attachments** menu, select the **Save Attachment** option.

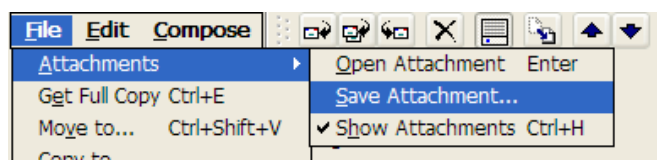

4. The Save As dialog box will appear. Navigate to where you want to store the attachment. Name the document as desired, and click **OK**.

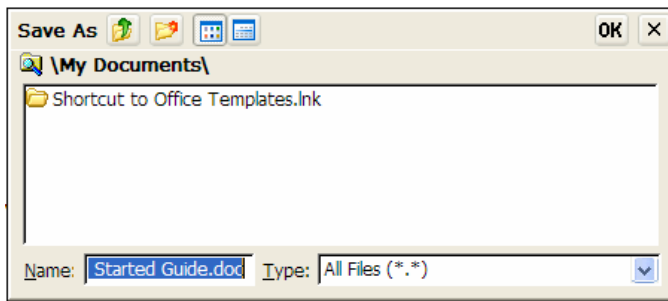

NOTE: ATTACHMENTS CAN LATER BE RENAMED OR DELETED FROM THE SAVE AS SCREEN BY RIGHT CLICKING ON THE ATTACHMENT. THIS FUNCTION IS ALSO AVAILABLE FROM THE FILE | OPEN DIALOG BOX IN THE VIEWER.



CAUTION: SAVING ATTACHMENTS TO THE THIN CLIENTS LOCAL STORAGE WILL CONSUME VALUABLE RAM. USING AN OPTIONAL USB STORAGE DEVICE WILL FREE UP THE LOCAL RAM FOR USE BY THE THIN CLIENTS PROGRAMS.

Reply to or Forward a Message

1. Open the message, and then select **Compose | Reply to Sender, Reply to All, or Forward**. You also may use the respective icons on the tool bar.



2. The Compose screen will appear. The original message may be also included depending upon the settings on the Options | Compose screen. **Enter** your response.
3. Select **File | Send**.

Add the Sender to Address Book

Open the message, and then select **Compose | Add Sender to Address Book**. A new contact card will open with the sender's name and e-mail address already entered.

Or

Select **Go | Address Book** or click on the Address Book icon.

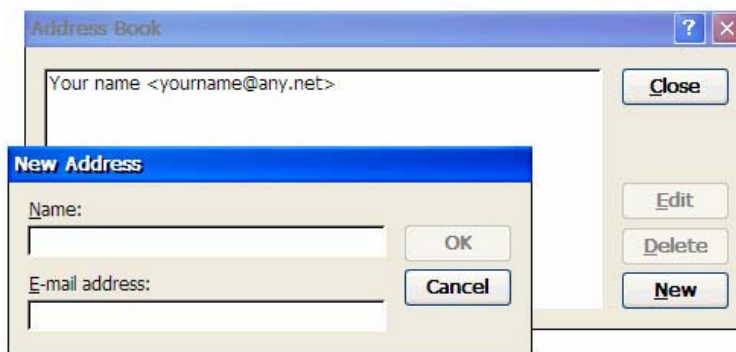

- To add a new entry, select **New**. Enter the name you want to type in the To and CC fields of messages in the Name field.
- To delete an entry, select it, and then select **Delete**.
- To edit an entry, select it, and then select **Edit**.

Print a Message

You may send a message to the locally attached printer. This printer function does not require setting up any RDP, LPD or Citrix printers.

1. Open the message.
2. Select **File | Print**, and the following screen appears. Make the appropriate selections based upon the printer attached. Click the **OK** button on the Title line (upper right hand corner of the dialog box).

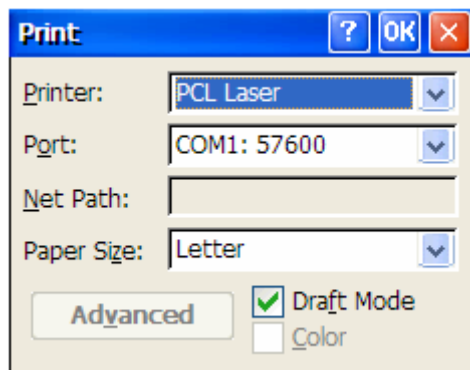

- **Printer:** Microsoft only provides one print driver – a PCL laser driver – for the locally attached printer.
- **Port:** Select the appropriate serial or parallel port. If a USB printer is attached, select LPT2.
- **Net Path:** If the printer is attached to the LAN, enter the fully NetBios path.
- **Paper Size:** Select the appropriate paper size.
- **Draft Mode:** Select whether to print in draft or final mode.

Composing and Editing Messages

Create a Message:

1. In the Message List view, select. **Compose | New Message** or **click the New Message icon**.

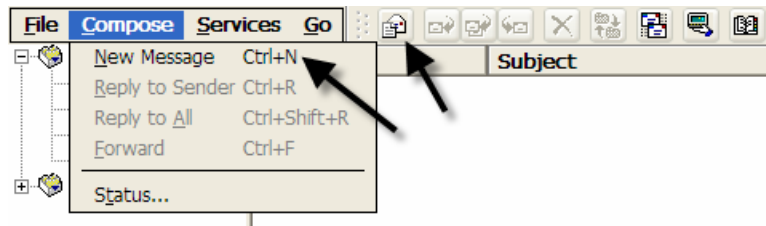

NOTE: ICONS ON THE TOOL BAR ARE AVAILABLE TO PERFORM MANY OF THE MENU OPTIONS.

2. The Compose screen will appear. On this screen, you will find four areas: The menu/tool bar, the header, the body of the message, and the attachments listing.

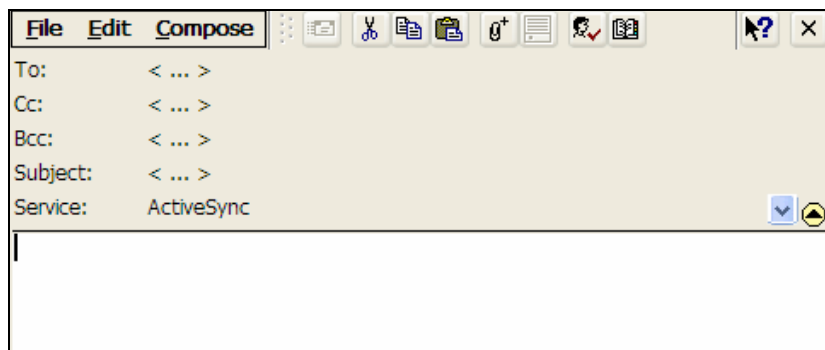

3. **Enter** the address of one or more recipients, separating them with a semicolon. If the recipient is listed in the Address Book, enter a few letters of the recipient's name and select **Compose | Check Names** (or click on the appropriate icon on the tool bar).. If there is only one match, the e-mail address is inserted. If there is more than one match, select the correct address from the Choose E-mail Recipients dialog box. If there is no match, add a new e-mail address through Choose E-mail Recipients. To include a blind copy, expand the header by selecting **Compose | Show Full Header** (or click on the appropriate icon on the tool bar).
4. To attach a file, select **File | Attachments | Add Attachment** (or click on the appropriate icon on the tool bar). Navigate to where the file is stored. Highlight the file, and click **OK**.
5. To save the message you are composing or editing, select **File | Save**. The message is not sent and is saved in the Inbox folder of the active service.
6. To send the message, select **File | Send** (or click on the appropriate icon on the tool bar). If you are working offline, the message is moved to the Outbox folder and will be sent the next time you connect.

Menu and Tool Bar Icon Descriptions

File Menu

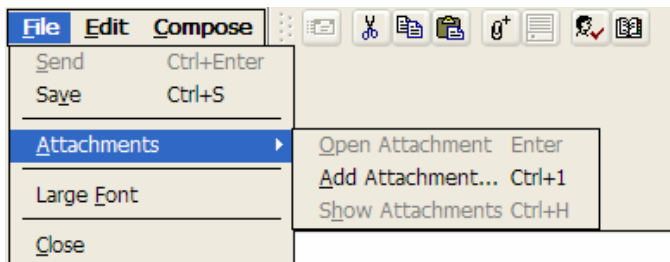

- **Send:** Sends the current message. If you are working offline, the message is placed in the Outbox and will be sent when a connection to the e-mail server is established.
- **Save:** Saves the current message in the Inbox. You may open it later, edit it and either save or send it at that time.
- **Open Attachments:** Select to open the attachments to the message.
- **Save Attachment:** Presents a dialog box allowing you to choose where to store the attachment.
- **Show Attachments:** Toggles on and off the display of attachments in the lower portion of the message screen.
- **Large Font:** Increases the font size of the message.
- **Close:** Closes the message. You may also click on the “X” button on the Menu/Tool Bar line.

Edit Menu

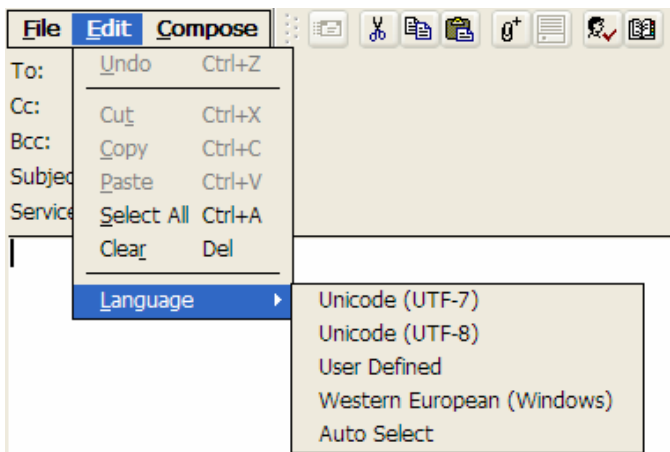

- **Undo:** Reverses the last action.
- **Cut:** Removes the selected text.
- **Copy:** Copies the selected text to the clipboard.
- **Paste:** Pastes the contents of the clipboard at the point where the cursor is located.
- **Select All:** Selects all text.
- **Clear:** Clears the selection.
- **Language:** Provides a selection of different languages to use to send the message.

Compose Menu

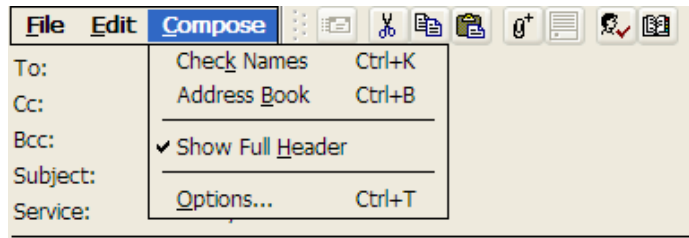











- **Check Names:** When entering an e-mail address, this option will cause the address book to be checked for a matching entry. If more than one entry exists, the address book will be presented allowing you to select which is the desired address.
- **Address Book:** Causes the address book to be presented.
- **Show Full Header:** Causes the expanded header to be presented or collapsed.
- **Options:** Causes the Options dialog box to be presented.

Tool Bar Icons

The Tool Bar (located to the right of the menus) provides quick one-click access to certain menu functions.



Tool Bar Button	Description
	Send the message
	Cut the selected text
	Copy the selected text
	Paste the contents of the clipboard
	Add an attachment
	Show attachments in the attachments block
	Check address book
	Address book
	Show full header (located in the Header block)
	Collapse the header (located in the Header block)

Organizing Messages

Move or Copy a Message

1. On the Message List view, select the message.

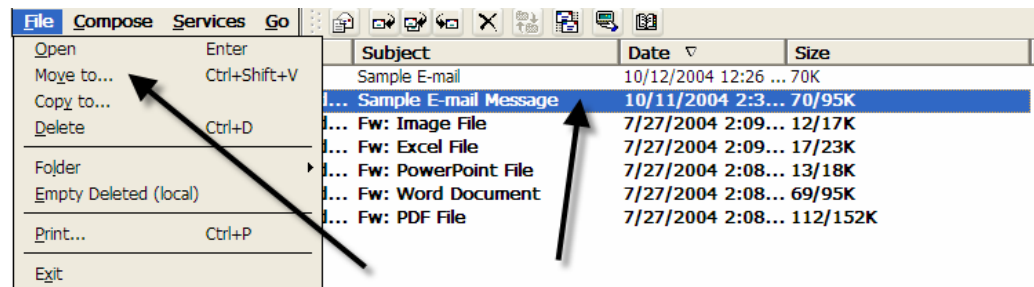

2. Select **File | Move To** or **File | Copy To**.
3. Select the destination folder.

If you are working offline, the message will be moved or copied from the e-mail server the next time you connect.



CAUTION: WHEN YOU MOVE A MESSAGE THAT YOU HAVE RECEIVED THROUGH POP3 OR SYNCHRONIZATION TO A FOLDER YOU CREATED ON YOUR THIN CLIENT, THE COPY OF THE MESSAGE ON THE E-MAIL SERVER IS DELETED. THIS PREVENTS DUPLICATE COPIES OF MESSAGES. ALTHOUGH THE COMPLETE MESSAGE IS MOVED, MESSAGE ATTACHMENTS WILL BE DELETED IF YOU HAVE NOT SELECTED THE OPTION TO DOWNLOAD ATTACHMENTS. ONCE THE MESSAGE IS MOVED, YOU WILL BE ABLE TO ACCESS THE MESSAGE ONLY FROM YOUR THIN CLIENT.

Delete a message

1. On the Message List view, **Select the message**.

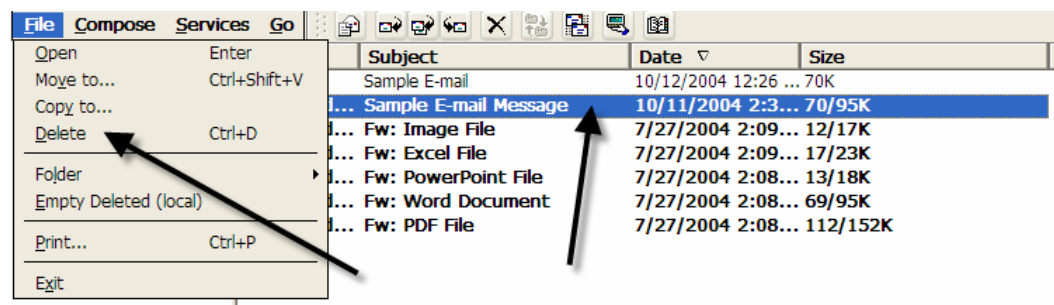

2. Select **File | Delete**. Messages are moved to the Deleted (local) folder and deleted according to the option you have selected in **Services | Options | Delete** tab:
 - On connect/disconnect: Deletes messages when you connect or disconnect from your mail service or exit Inbox.
 - Immediately: Deletes messages as soon as you select **File | Delete**.
 - Manual: Deletes messages when you select **File | Empty Deleted (local)**.



NOTE IF YOU ARE WORKING OFFLINE, MESSAGES THAT HAVE BEEN DELETED FROM THE SERVER WILL BE DELETED FROM THE DEVICE THE NEXT TIME YOU CONNECT.

Deleting Attachments

Attachments can be deleted using the file viewer Open File dialog box, or the e-mail Save As dialog box. In both cases, the same dialog box is opened.

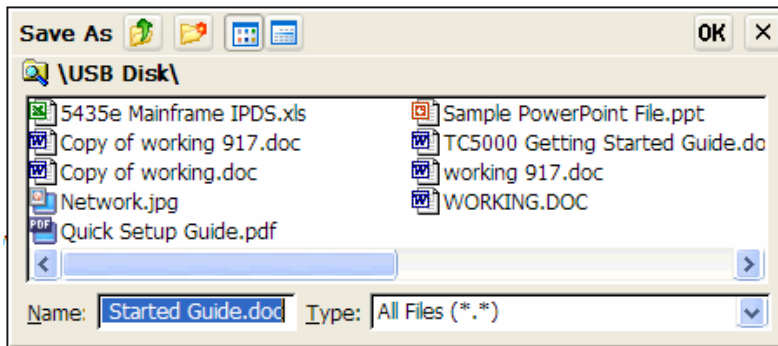

1. After navigating to the directory where the attachment or file is stored, **right click** on the desired file.

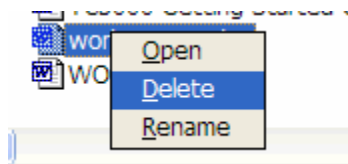

2. Click on the **Delete** option. Answer **Yes** to confirmation message.

Working with Folders

The e-mail client contains folders from mail services you have set up. When you set up a service, it appears in the Message List view. Each service contains four default folders: Inbox, Deleted (local), Outbox, and Sent. The Deleted (local) folder contains messages that have been deleted on the thin client. If you are using IMAP4, you may see a Deleted Items folder. This folder is for messages deleted on the e-mail server. The behavior of the Deleted (local) and Sent folders depends on the options you have chosen (see Services | Options | Delete tab).

You can also create your own folders. The behavior of the folders you create depends on whether you are using POP3 or IMAP4.

If you are using POP3 and you drag messages to a folder you created, the link is broken between the messages and their copies on the e-mail server. The next time you connect, the e-mail server will see that the messages are missing from the thin client's Inbox and delete them from the e-mail server. This prevents you from having duplicate copies of a message, but it also means that you will no longer have access to messages you move to folders you create from anywhere except the device.

If you are using IMAP4, the folders you create and the messages you move are mirrored on the e-mail server. For example, if you move two messages from the Inbox folder to a folder called Family, the e-mail server will create a copy of the Family folder and copy the messages into that folder. Therefore, messages are available to you anytime you connect to your e-mail server, whether it is from your thin client or another PC like device. This synchronization of folders occurs when you create a new folder, move messages into a folder, exit the Inbox program, or select Services | Synchronize Folders. If you want to view the messages in a folder while disconnected from your e-mail server, select the folder and then Services | Offline Folder.

Advanced Configuration

The thin client includes the ability to customize the various configuration options. These include display values, network connectivity, ICA and RDP options, etc.

This can be done either at the thin client or remotely using the I-O Configuration Utility.

I-O Configuration Utility

When using the I-O Configuration Utility, you will actually be using a keyboard and screen shadowing process called VNC. This means that the on the PC running the I-O Configuration Utility, you will see the actual screens on the thin client. Because the PC controls the keyboard and mouse on the thin client, you can run the thin client remotely as if you were sitting right in front of the thin client. Note that there will be a slight delay as the screens are being repainted on the PC – it takes a few moments for the screens to be compressed and transmitted to the PC.

1. On the PC, start the I-O Configuration Utility. The local subnet will be scanned and will display a listing of I-O Corporation devices. For remote sub-nets, set the scan options on the View | Scan Options screen to display the devices.

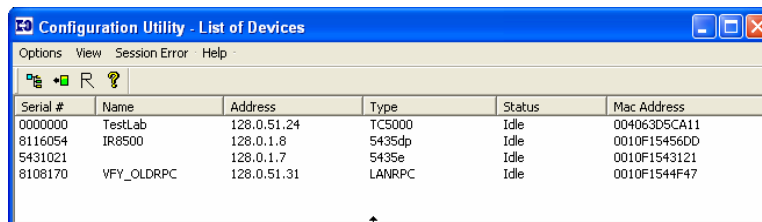

2. **Highlight** the desired thin client and click the  button. Alternately, you may **double click** the desire entry. **(Open Device Configuration)**

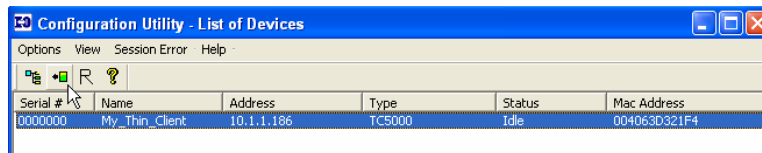

3. The VNC screen will appear and after a few seconds, the currently display screen on the thin client will be displayed. From this point the mouse and keyboard on the PC are controlling the thin client. As screens change on the thin client, they will be sent to the PC.



NOTE: PLEASE BE PATIENT – IT MAY TAKE A FEW SECONDS FOR THE SCREENS TO BE UPDATED ON THE PC.

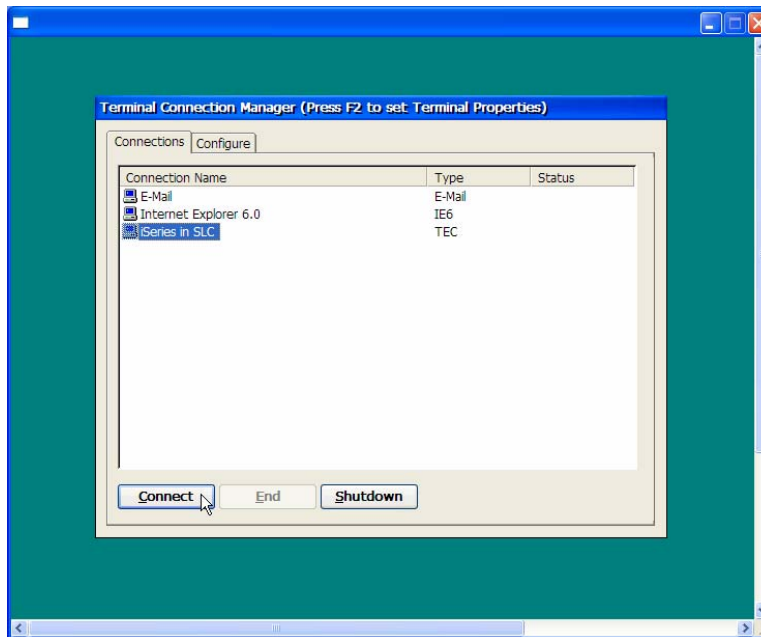

TIP: SETTING THE DISPLAY TO LOWER RESOLUTION AND COLOR PALLET WILL CAUSE THE THIN CLIENT SCREENS TO APPEAR FASTER ON THE PC.

4. You may now perform any function on the thin client (including running connections, etc.)
5. To end the VNC session with the thin client, click the red **X** button on the title line (the upper right corner of the VNC screen).



Save a Configuration

The I-O Configuration Utility provides a way to save a thin client's configuration. The configuration may then be sent back to the thin client if it were restored to factory defaults. Or a master configuration could be created and then sent to other thin clients so that the setup and installation of multiple thin clients can be may easier.

1. On the PC, start the I-O Configuration Utility. The local subnet will be scanned and will display a listing of I-O Corporation devices. For remote sub-nets, set the scan options on the View | Scan Options screen to display the devices.

Serial #	Name	Address	Type	Status	Mac Address
0000000	TestLab	128.0.51.24	TCS000	Idle	004063D5CA11
8116054	IR8500	128.0.1.8	5435dp	Idle	0010F1545600
5431021		128.0.1.7	5435e	Idle	0010F1543121
8108170	VFY_OLDRPC	128.0.51.31	LANRPC	Idle	0010F1544F47

2. **Highlight** the desired thin client. Then select the **Options | Thin Client Config Copy | Retrieve Configuration** option on the menu.

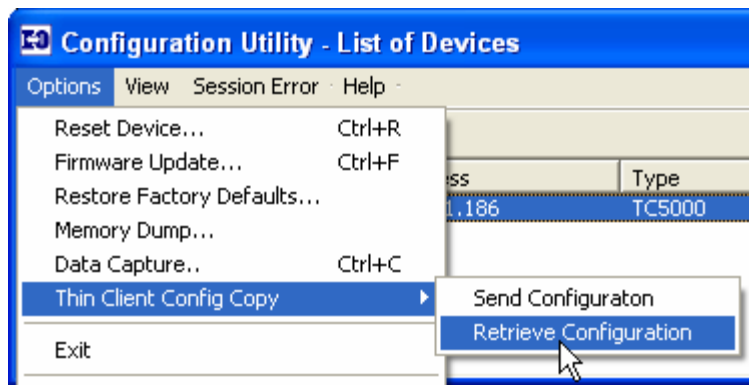

- The thin client's configuration will be retrieved. In the field, enter the name for this configuration file. If the file is to be saved in a different direction than where the I-O Configuration Utility is store, click **Browse** to change directories. Click **OK** to save the file.

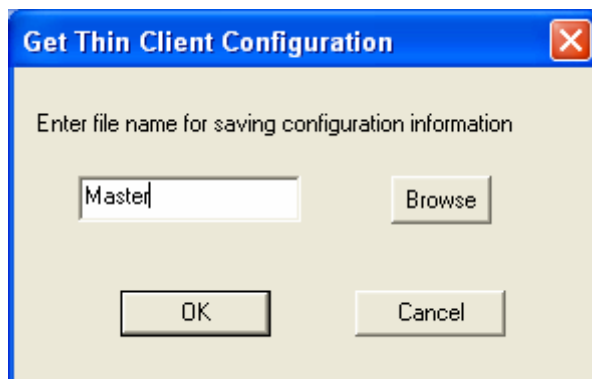

Send a Configuration to a Thin Client

Once a thin client's configuration has been saved, it can be sent back to the thin client to restore the customized configuration settings that were originally set up on the thin client. The file may also be a master configuration file that can be sent or pushed to any number of thin clients where a standard configuration has been established.

- listing of I-O Corporation devices. For remote sub-nets, set the scan options on the View | Scan Options screen to display the devices.

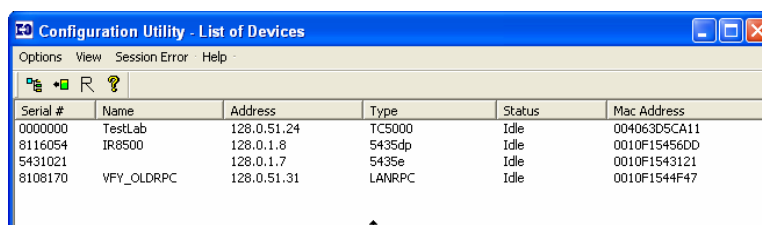

- Highlight** the desired thin client. Then select the **Options | Thin Client Config Copy | Send Configuration** option on the menu.

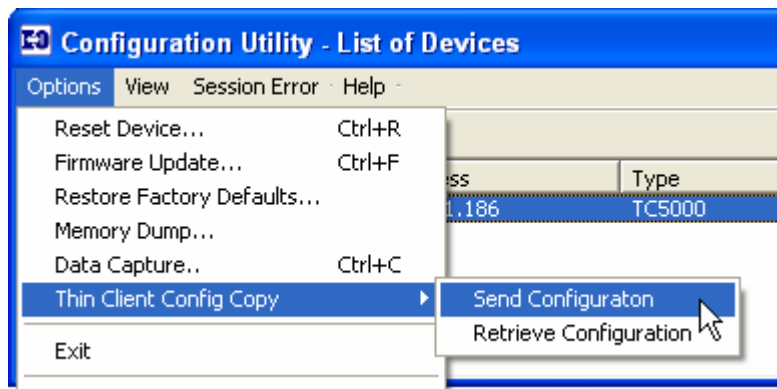

3. On the Put Thin Client Configuration screen, enter the name of the previously saved configuration file, or click the **Browse** button to find a file stored in a different directory. Click **OK** to send the file to the thin client.

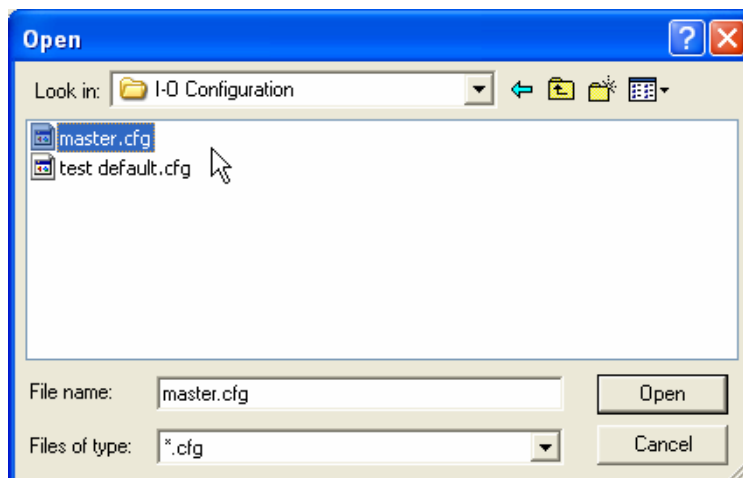
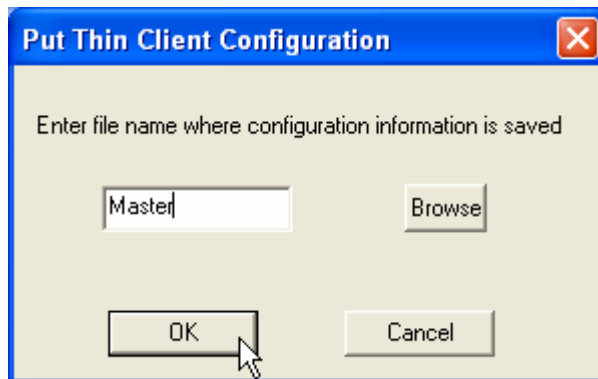

4. The configuration file be sent to the thin client.

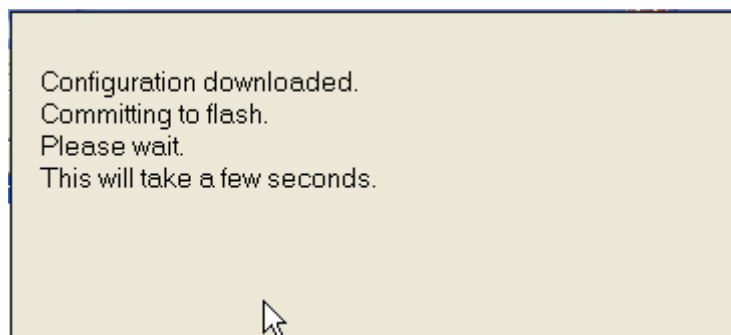

CAUTION: DO NOT POWER DOWN THE THIN CLIENT WHILE THE CONFIGURATION FILE IS BEING SENT TO THE THIN CLIENT. IF THE THIN CLIENT IS POWERED DOWN DURING THIS PROCESS, THE FLASH MAY BECOME CORRUPTED AND REQUIRED RETURNING THE THIN CLIENT FOR REPAIR.

5. After the configuration file has been sent to the thin client you will be asked to confirm resetting the thin client. Click **Yes**

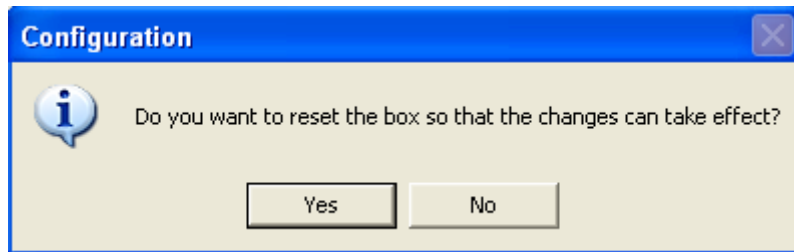

6. The thin client will restart and display the Connections Manager screen.

General Tab

To access the Terminal Configuration screens, on the Connection Manager press the **F2** key.

The General Tab presents information about the current version numbers of the various software modules that are contained in the thin client as well as Microsoft Product ID and I-O Serial Numbers.

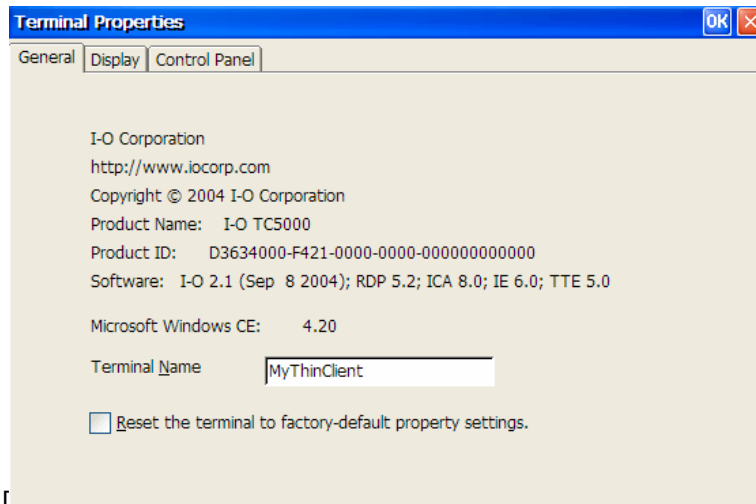

- **Terminal Name:** By default, the thin client has a unique name based upon the thin client's MAC address. You may either retain this name or enter another unique name the thin client will appear as on the I-O Configuration Utility. This name will also be used to identify this thin client to other computers when connected in a Microsoft or Citrix network environment. The name cannot begin with a numeric value, nor can it contain the following characters: \.":;/_~'@#\$\$%^&{}<>*+=|?., or space.
- **Reset to Factory Defaults:** Check this box to cause the thin client to be restored to the factory defaults. You will be asked if you really want to reset the thin client. Then you will need to click the **OK** button on the title line (upper right corner).



CAUTION: SELECTING THIS OPTION WILL CLEAR ALL CONFIGURATION SETTINGS. BE CERTAIN YOU WANT TO RESTORE THE THIN CLIENT TO ITS FACTORY DEFAULTS BEFORE TAKING THIS OPTION.

Display Tab

This tab offers options on selecting the proper resolutions for the monitor attached to the thin client, color pallets and the screen saver.

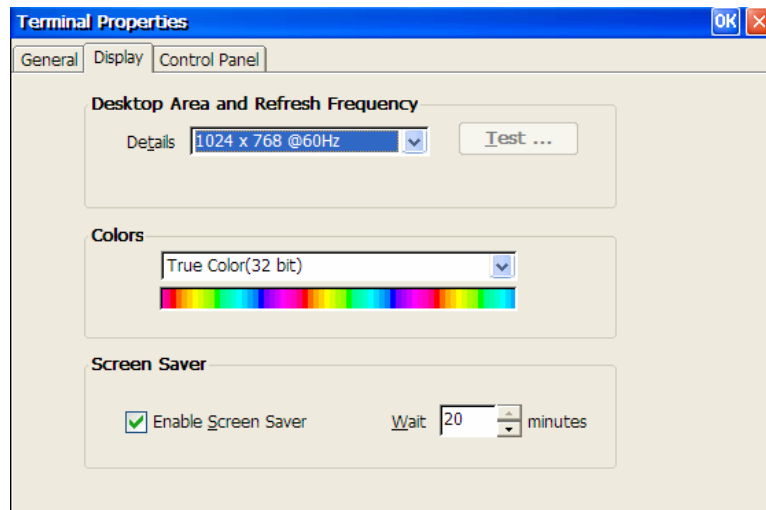

Desktop Area and Refresh Frequency

By default, the thin client is configured to display at a resolution of 800 x 600 and a refresh frequency of 75Hz.

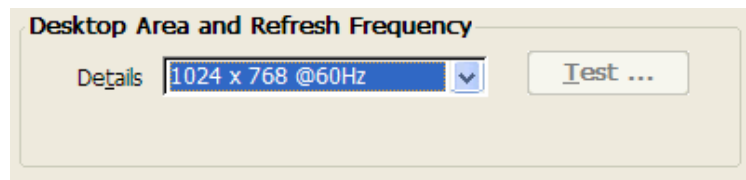

Select the resolution and refresh rate appropriate for your monitor.



NOTE: IN GENERAL CRT MONITORS CAN HANDLE A RANGE OF RESOLUTIONS AND REFRESH RATES. HOWEVER, LCD MONITORS PREFER THE RESOLUTION AND REFRESH RATE TO BE SET TO MATCH THEIR "NATIVE" RESOLUTION. GENERALLY THIS IS 1024 X 728 @ 60 HZ FOR 15" LCD MONITORS, AND 1280 X 1024 @ 60 HZ FOR 17" LCD MONITORS

If you select a resolution or refresh frequency other than the default setting, verify whether your monitor supports the selected setting by clicking the Test button.

The following prompt is displayed.

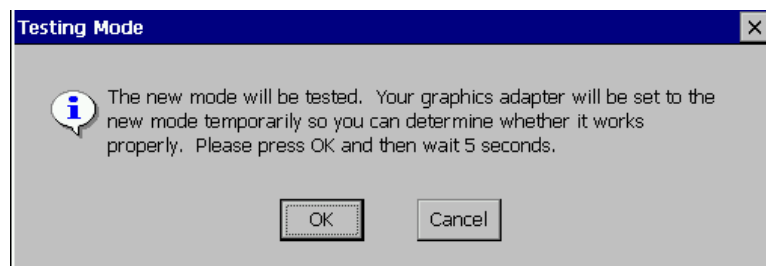

Click **OK** to continue. A test pattern of black and white boxes will be displayed for about five seconds.



NOTE: MONITORS WITH ON SCREEN DISPLAY (OSD) FEATURE MAY DISPLAY APPROPRIATE MESSAGES (SUCH AS 'OUT OF SYNC' OR 'OUT OF RANGE') IF THE SELECTED RESOLUTION AND FREQUENCY ARE

NOT SUPPORTED. THE EXACT TEXT OF THE OSD MESSAGE WOULD DEPEND ON THE MODEL OF THE MONITOR CONNECTED TO THE THIN CLIENT.

The screen then clear and a following message box will be displayed.

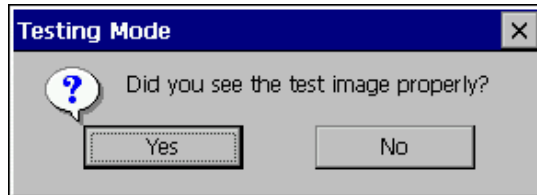

- If the appropriate test pattern was displayed, click **Yes** to return to the setup wizard.
- If the test pattern was not properly displayed, click **No**. The following message is displayed.



Click **OK** to change the setting and repeat the test.



CAUTION: USE THE **TEST** BUTTON TO TEST THE SELECTED RESOLUTION OF THE MONITOR. *FAILURE TO DO SO WILL RESULT IN THE THIN CLIENT NOT BEING ABLE TO DISPLAY THE SCREEN.*

IF YOU HAVE SELECTED AN UNSUPPORTED SETTING AND THE MONITOR DOES NOT DISPLAY THE SCREEN, YOU WILL NEED TO RESTART THE THIN CLIENT. SHUT DOWN THE THIN CLIENT BY HOLDING IN THE POWER BUTTON FOR SEVERAL SECONDS UNTIL THE POWER LED GOES OUT. PRESS THE POWER BUTTON TO POWER UP THE THIN CLIENT. IMMEDIATELY AFTER THE I-O SPLASH SCREEN CLEARS, PRESS THE **F7** KEY SEVERAL TIMES. AFTER A FEW SECONDS THE THIN CLIENT'S SETTINGS WILL BE RESTORED TO THE FACTORY DEFAULTS AND THE **SETUP WIZARD** WILL START.

Colors

Select the color pallet that your monitor supports from the Colors drop down box

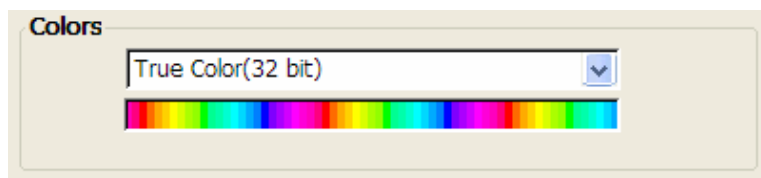

Screen Saver

Enable the screen saver, if desired, by checking the Enable Screen Saver box. Select the time to wait before the screen activates from the scroll box.

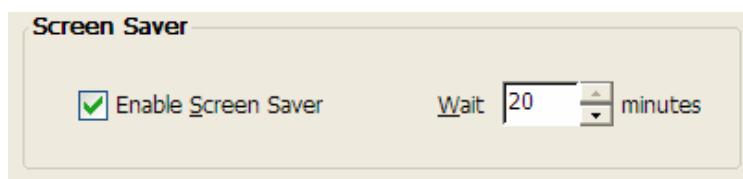

Control Panel

The Control Panel offers options to customize many of the functional aspects of the thin client. After making the various settings, click **OK** to or the **X** in the upper right corner to exit the Terminal Properties screens and return to the Connection Manager.



Internet Options

Use this option to change the default values for the Internet Explorer 6 for CE application. The screens may also be accessed by taking the View | Options menu selection when running Internet Explorer (IE).

General Tab

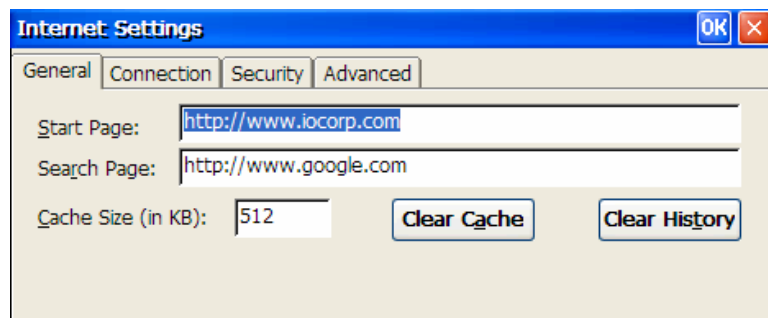

- **Start Page:** Enter the Web you want the Internet Explorer to go to when IE is started.
- **Search Page:** Enter the Web page you want to go to when selecting the Search option on the IE menu.
- **Cache Size:** Enter the amount of RAM to use for caching Web pages.
- **Clear Cache:** Click this button to empty the cache.
- **Clear History:** Click this button to clear the history of Web pages visited.

Connection Tab

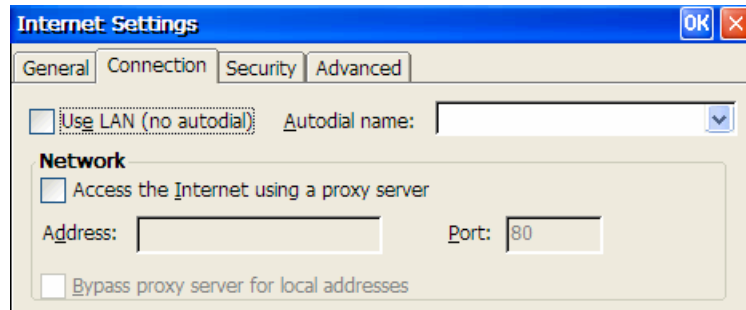

Enter values on this screen to customize the connection.



NOTE: IF THE INTERNET CONNECTION IS BEING MADE THROUGH THE ETHERNET LAN, NO CHANGES ARE REQUIRED ON THIS PAGE.

Security Tab

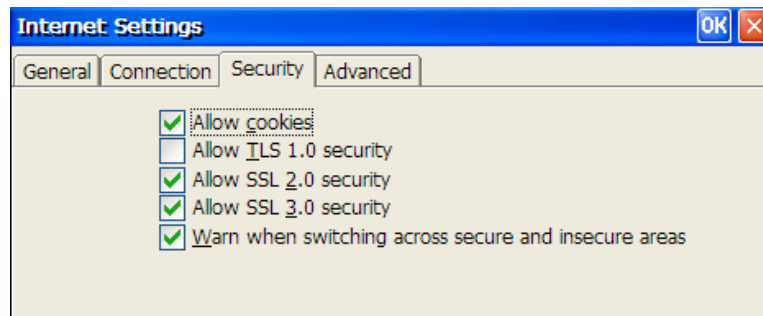

Select the various security levels and cookies options desired for the IE connection.

Advanced Tab

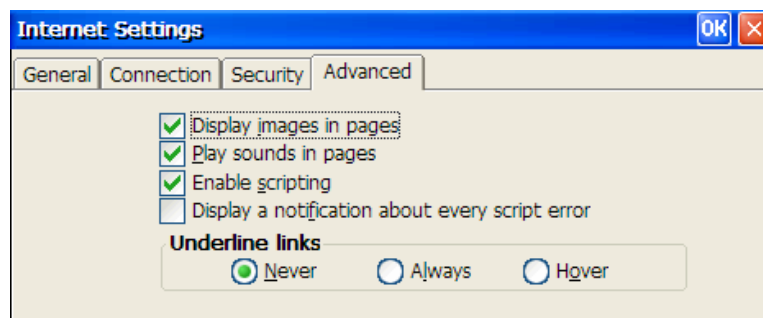

Select the display, sound, scripting and links options as desired.

RDP Printers

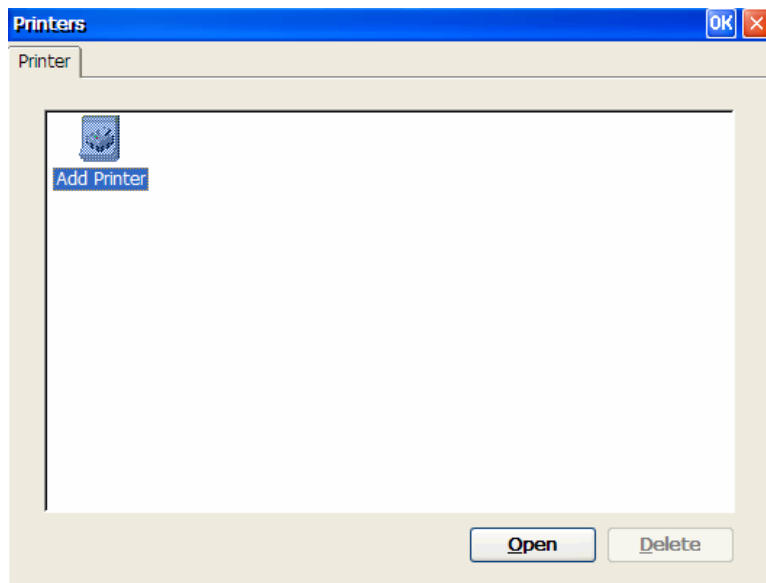

The RDP Printer option provides access the local printer configuration tool.



THE PRINTERS WITH THIS TOOL ARE USED ONLY BY RDP CONNECTIONS TO WINDOWS 2000 OR LATER SERVERS WITH TERMINAL SERVICES ACTIVE. RDP PRINTERS ARE NOT USED BY ICA, INTERNET EXPLORER, OR ANY OF THE VIEWERS.

To setup a RDP printer, click the **Add Printer** icon and follow the Add Printer Wizard.

Keyboard

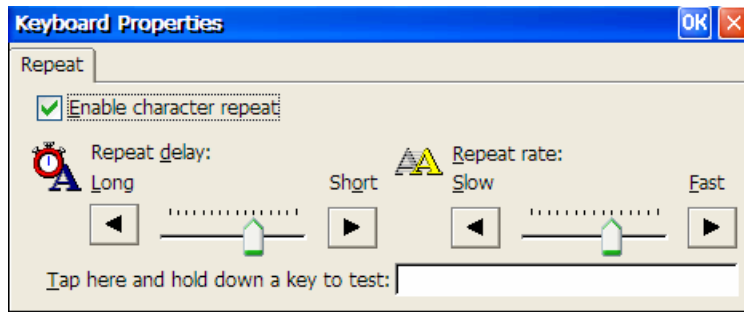

The options on this screen are used to enable and customize how character repeat will function.

System

General Tab

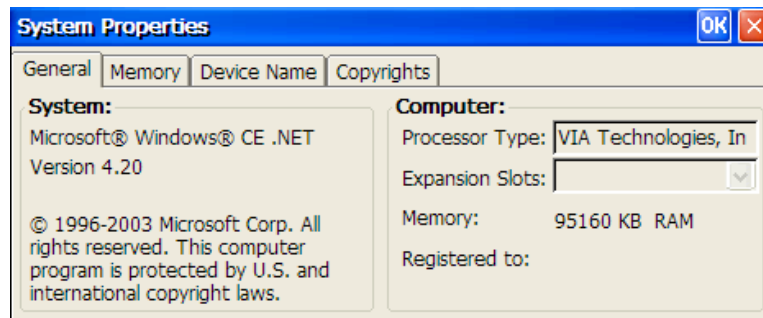

This screen presents general information about the thin client.

Memory

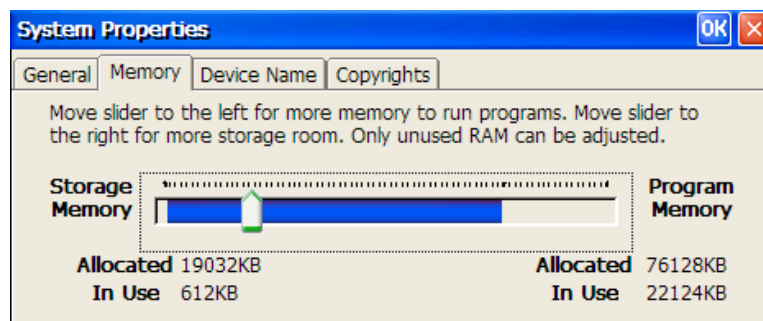

Use this screen to select how much of the RAM in the thin client can be used for local storage for IE cookies, history, and cache as well as will be available for storage of e-mail attachments. Additional storage may be added to the thin client for attachments by using a USB external storage device.

Program memory usage increases as connections are used. For example, twenty terminal emulation connections may be configured, but if only one is used, the program memory utilization will be small (for example 4000kb). If all twenty terminal emulation connections were active, the program memory utilization would be much larger (for example 15000kb). The thin client has successfully been tested with twenty sessions active. The limit of active sessions will be determined by the amount of available memory not being used by storage.

Device Name



This screen can also be used to change the device name. This name will be displayed on the List of Devices in the I-O Configuration Utility as well as to other computers in a Microsoft network.

Copyrights

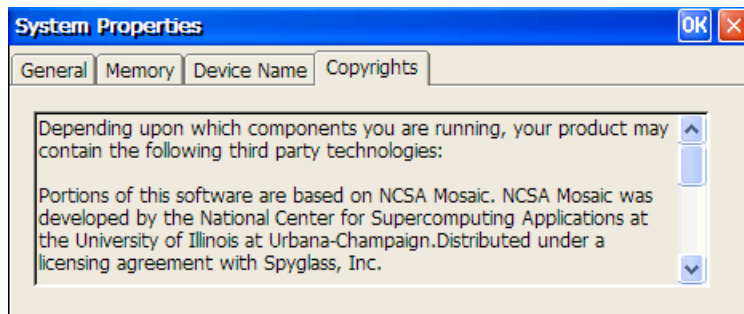

This screen displays the copyrights for various modules used in the thin client.

Mouse

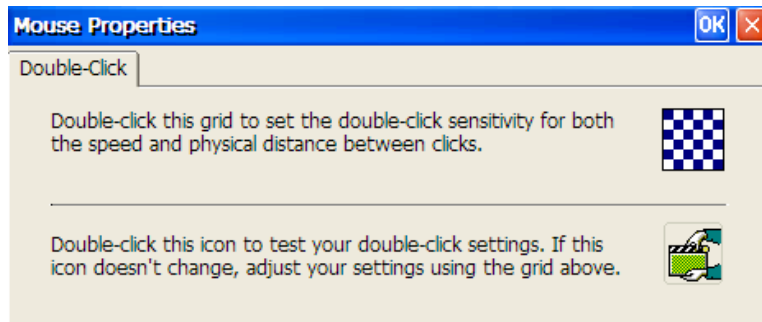

Use these options to set the double-click rate of the mouse buttons and to test that rate.

Volume and Sounds

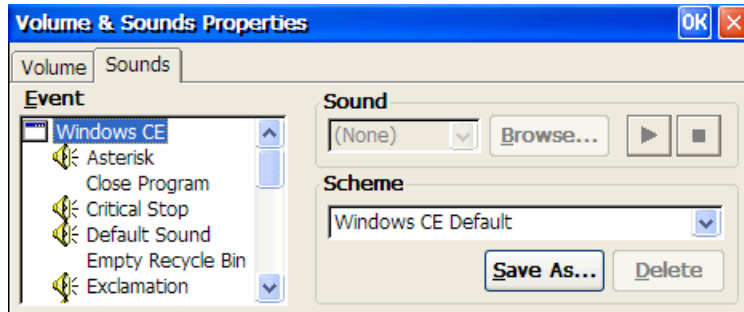
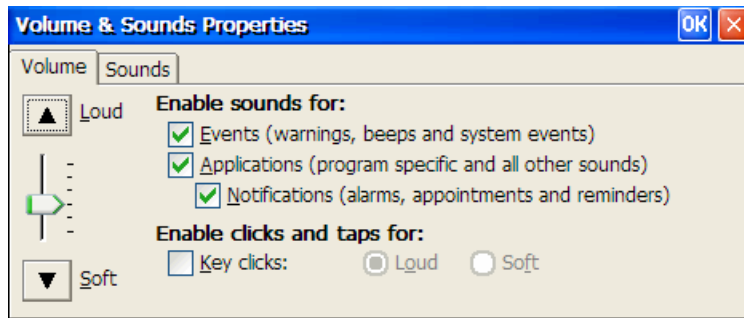

These two screens are used to enable sounds for various application actions, set the default volume, and customize sounds and schemes to the user's desire.

Certificates

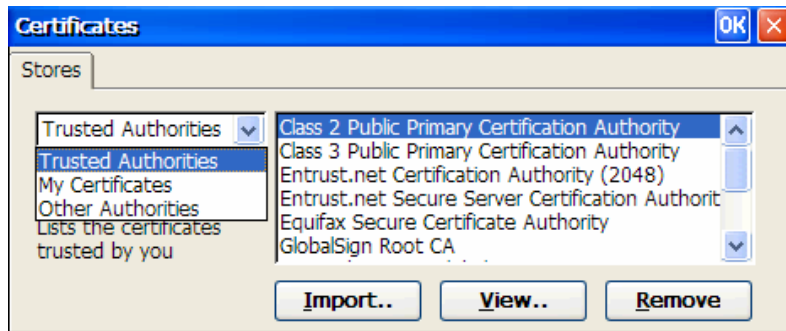

This screen shows the various certificates that are available on the thin client. These are organized by different types that are selected in the left drop down box.

Regional Settings

Regional Settings Properties ? OK X

Regional Settings | Number | Currency | Time | Date

Your locale
The locale option affects how some programs format numbers, currency, time and dates.

English (United States) ▼

User Interface Language
The option will determine the language used for the menus, dialogs and alerts.

English (United States) ▼

Regional Settings Properties ? OK X

Regional Settings | Number | Currency | Time | Date

Appearance

Positive: 123,456,789.00 Decimal symbol: . ▼
 Negative: -123,456,789.00 No. of digits after decimal: 2 ▼
 Negative number format: -1.1 ▼ Digit grouping symbol: , ▼
 Display leading zeros: 0.7 ▼ No. of digits in group: 3 ▼
 Measurement system: U.S. ▼ Negative sign symbol: - ▼
 List separators: , ▼

Regional Settings Properties ? OK X

Regional Settings | Number | Currency | Time | Date

Appearance: Positive: \$123,456,789.00
 Negative: (\$123,456,789.00)

Currency symbol: \$ ▼ No. of digits after decimal: 2 ▼
 Digit grouping symbol: , ▼ Position of currency symbol: =1.1 ▼
 No. of digits in group: 3 ▼ Negative number format: (=1.1) ▼
 Decimal symbol: . ▼ * = Universal currency symbol

Regional Settings Properties ? OK X

Regional Settings | Number | Currency | Time | Date

Appearance

Time sample: 9:40:09 AM AM symbol: AM ▼
 Time style: h:mm:ss tt ▼ PM symbol: PM ▼
 Time separator: : ▼

Regional Settings Properties ? OK X

Regional Settings | Number | Currency | Time | Date

Calendar: Gregorian Calendar ▼

Short Date **Long Date**

Sample: 9/13/2004 **Sample:** Monday, September 13, 2004

Style: M/d/yyyy ▼ Style: dddd, MMMM dd, yyyy ▼
 Separator: / ▼

Use these screens to customize the languages, number formatting, currency formatting, time formats and date formats that are used by the various applications that are both available locally as well as when connected to a Microsoft terminal server or Citrix server.

Network and Dialup Connections

The default connection for the thin client is through an Ethernet connection. If other types of connections are desired, they can be added using this icon.

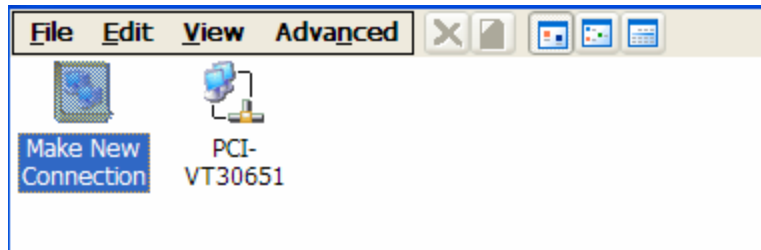

To add a new connection, double click the **Make New Connection** icon. The following screen will be presented. Select the type of new connection to create and follow the appropriate wizard.

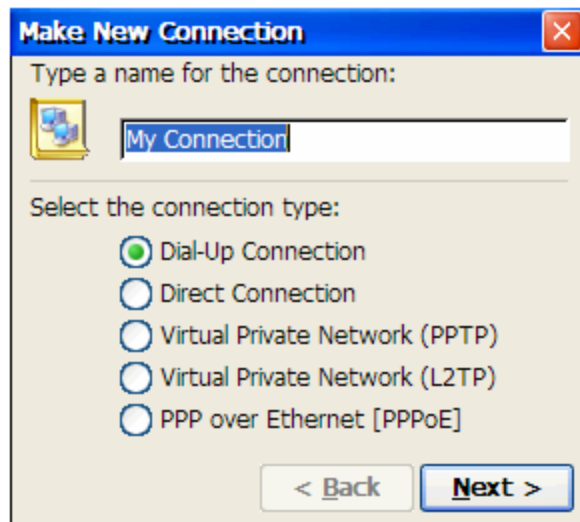

Note: Refer to your network administrator, Microsoft Certified Systems Engineer, or Citrix Network Engineer for information necessary for complete the screens in this section to create and use these types of connections.

Dial-UP Connection

Use the following screens to create a modem connection and set the various configuration values for the modem's use.

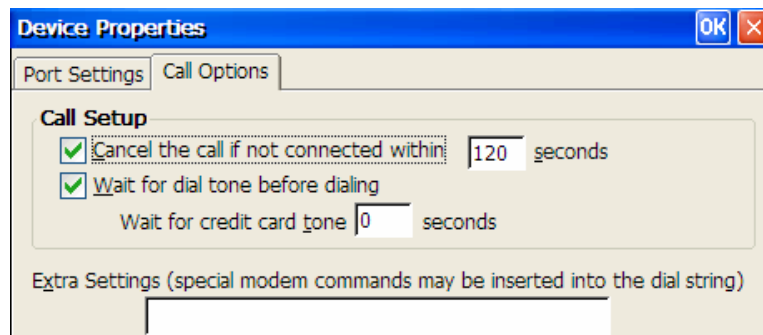
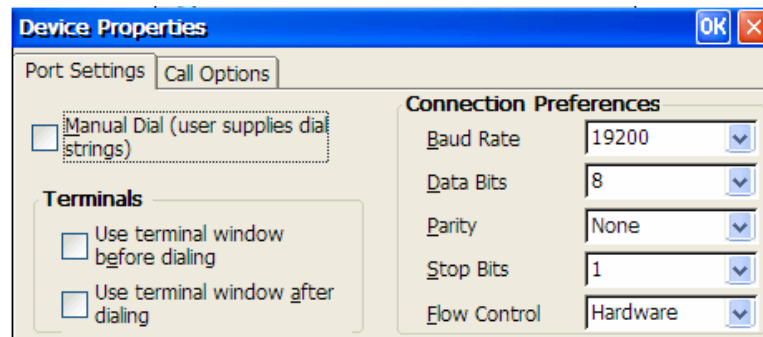
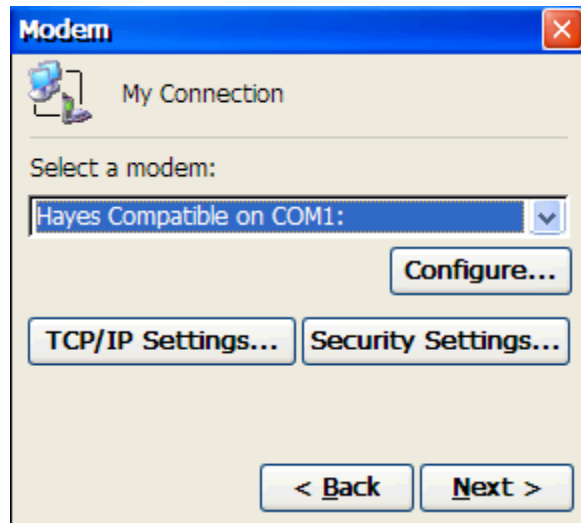

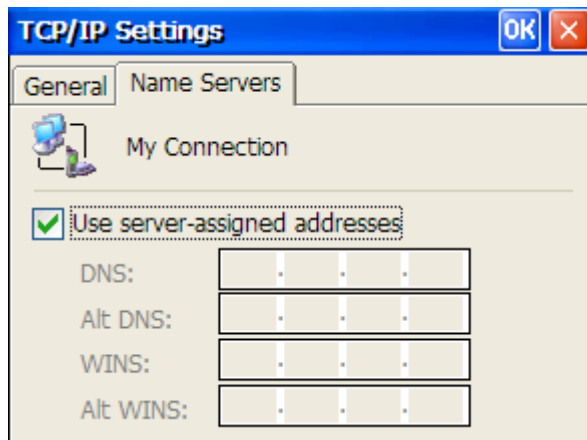
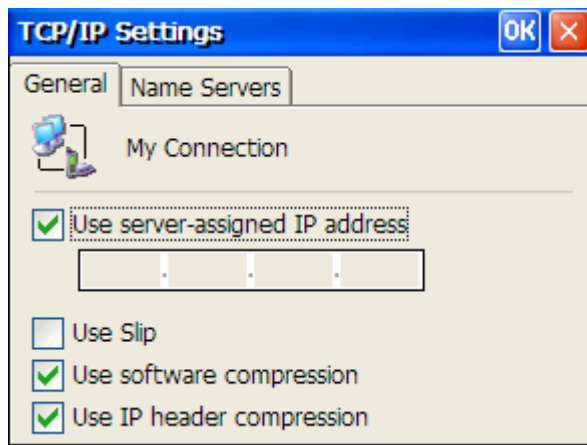

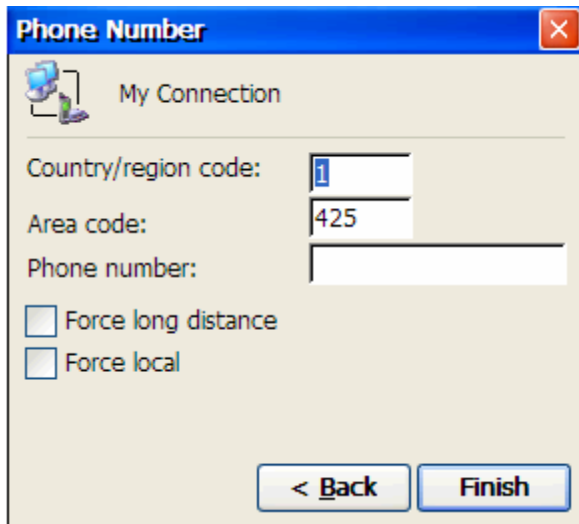

Phone Number [Close]

My Connection

Country/region code:

Area code:

Phone number:

Force long distance

Force local

< Back Finish

Direct Connection

Use these screens to setup and configure a direct connection (no modem is used) to be used by the thin client for connection to the server.

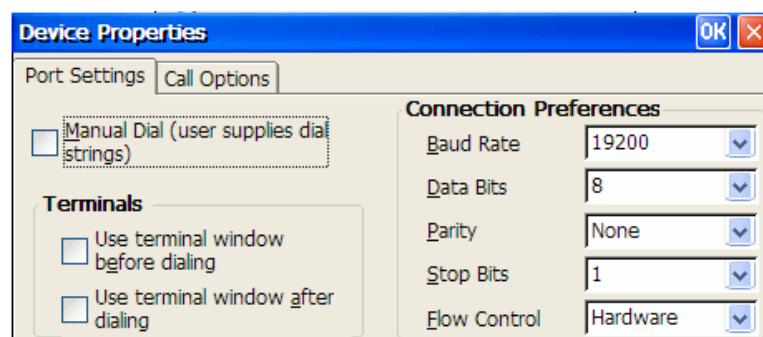
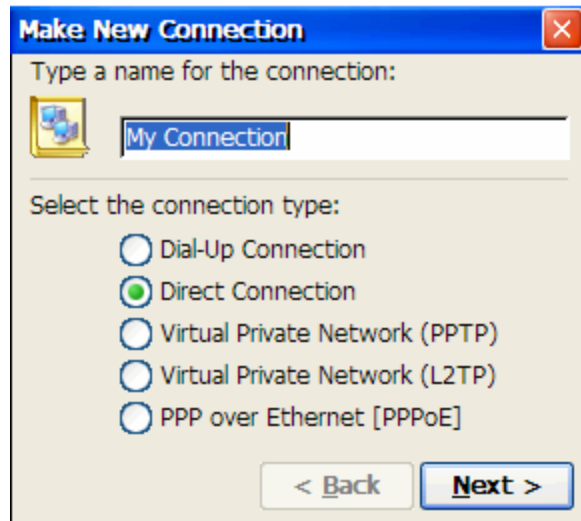

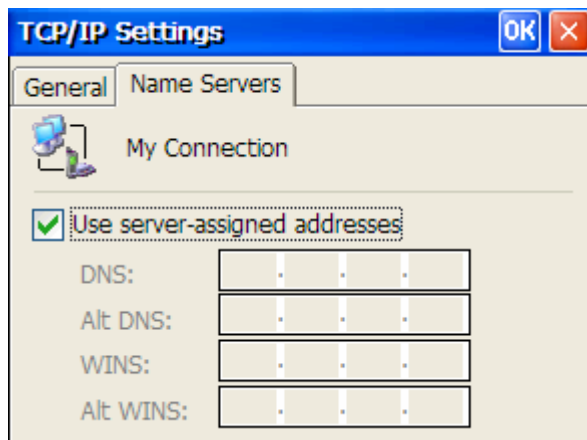
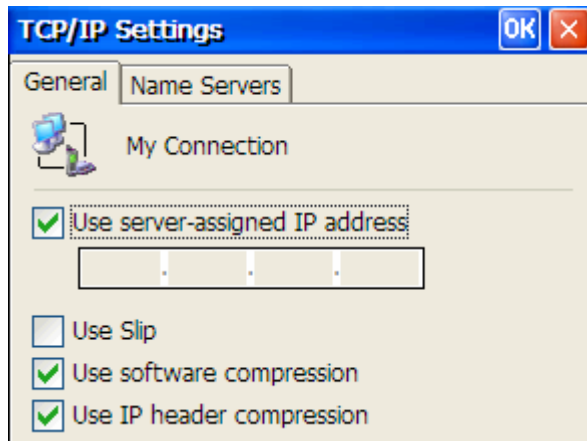
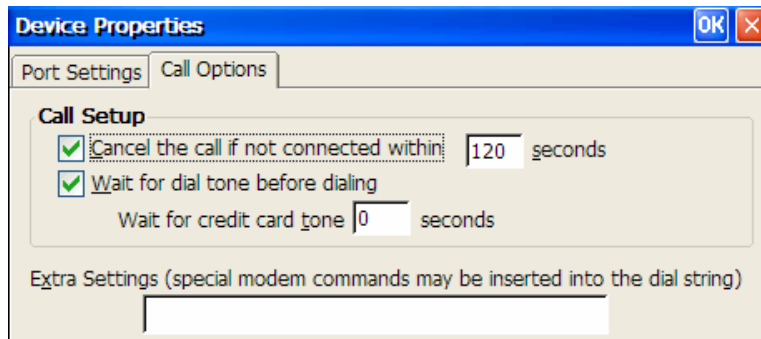

Virtual Private Network (PPTP)

Use these screens to establish a VPN connection for the thin client.

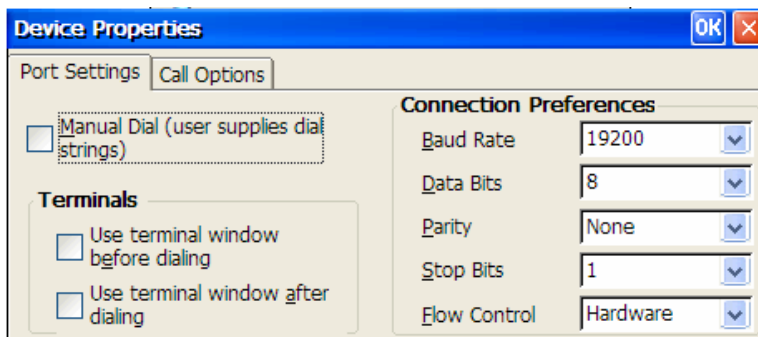
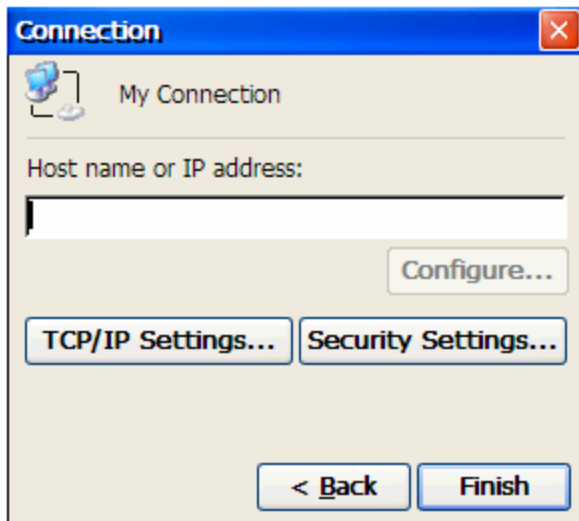
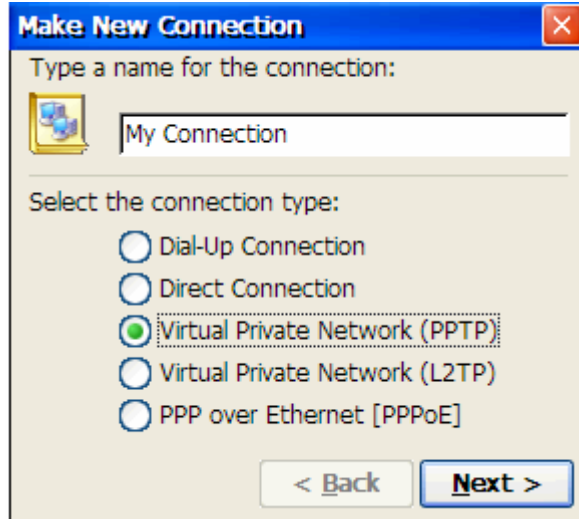

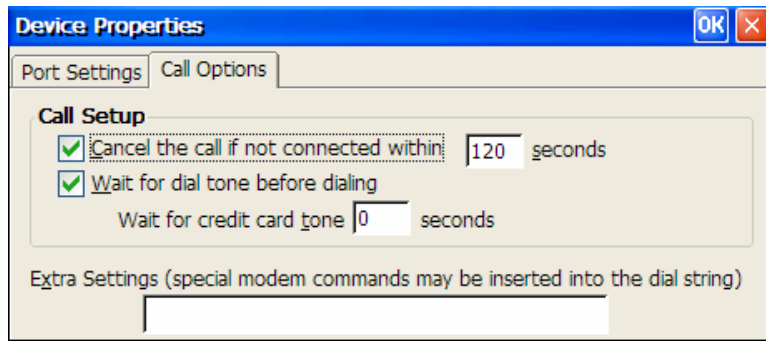

Virtual Private Network (L2TP)

Use the screens in this section to create a L2TP type of VPN connection.

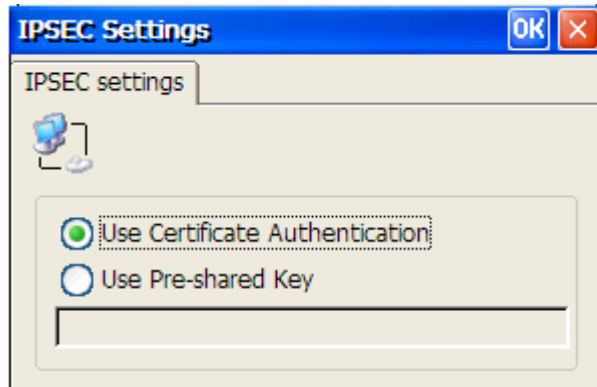
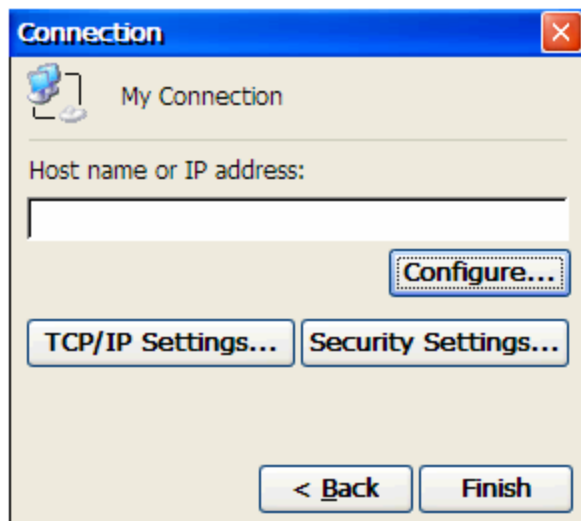
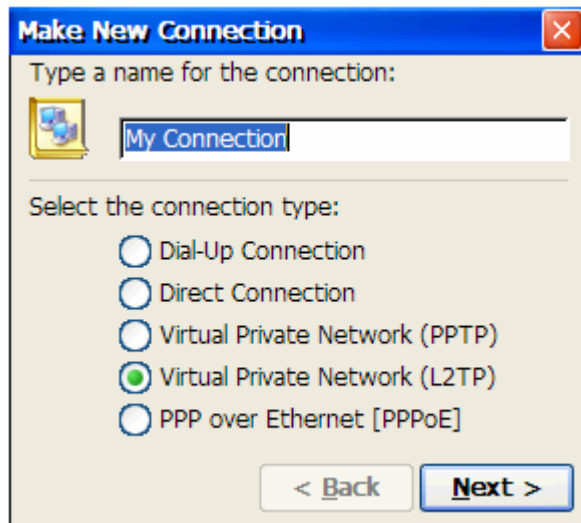

Device Properties [OK] [X]

Port Settings | Call Options

Manual Dial (user supplies dial strings)

Terminals

Use terminal window before dialing

Use terminal window after dialing

Connection Preferences

Baud Rate: 19200

Data Bits: 8

Parity: None

Stop Bits: 1

Flow Control: Hardware

Device Properties [OK] [X]

Port Settings | Call Options

Call Setup

Cancel the call if not connected within: 120 seconds

Wait for dial tone before dialing

Wait for credit card tone: 0 seconds

Extra Settings (special modem commands may be inserted into the dial string)

PPP over Ethernet (PPPoE)

Use these screens to setup a PPP over Ethernet connection for the thin client.

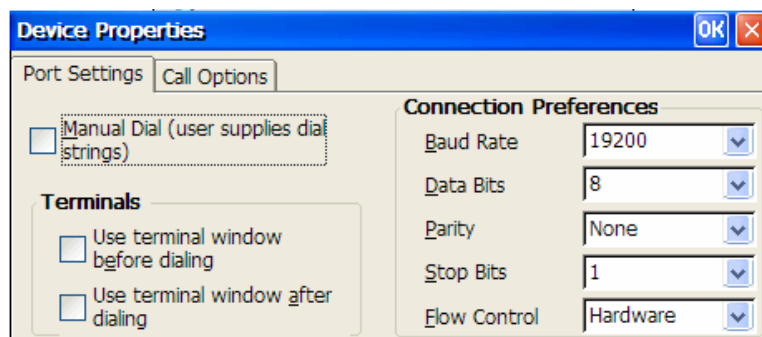
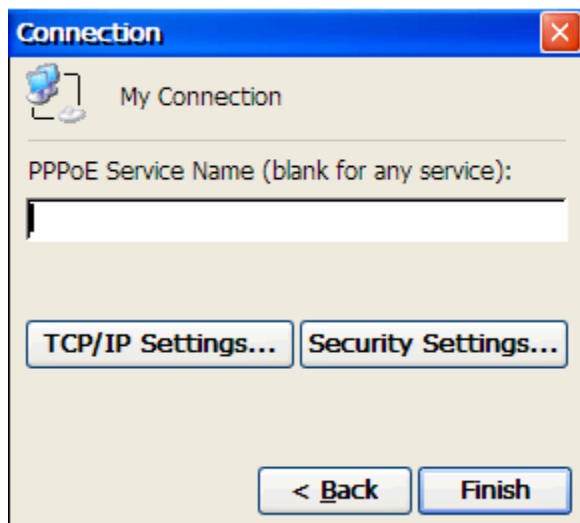
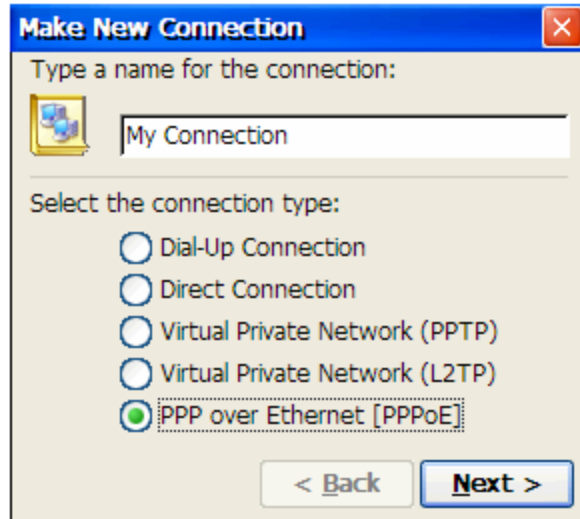

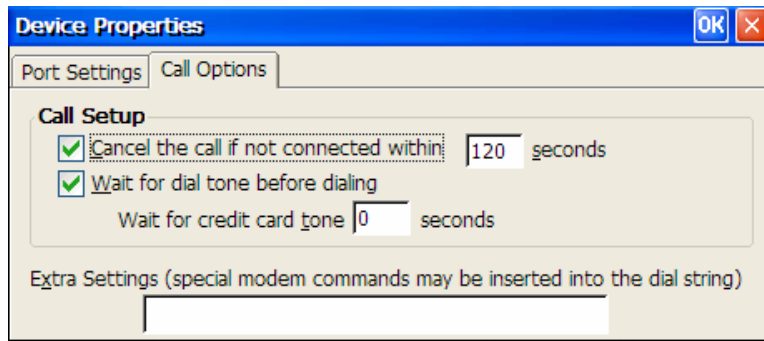

LPR/LPD

LPD (Line Printer Daemon) printing allows a printer connected to the thin client to be used through any server that can print using the LPR/LPD protocol (UNIX, Linux, Windows, mainframes, etc.). This TCP/IP printing protocol is widely used because of its simplicity of configuration and use.

- **Enable LPR/LPD Printing:** Check this box to enable LPD printing.
- **Que Name:** Enter a name that will be used to identify this LPD printer session when the LPR host (such as the UNIX server) is being set up to send print jobs to the printer attached to the thin client.
- **Printer Port:** Select from the drop down box the physical port that the printer is attached to.
- **Baud Rate:** If COM1 is selected as the printer port, this drop down box will become active allowing you to select the baud rate used to communicate with the serial printer.
- **Print Header Page:** Check this box to have the header page printed at the beginning of each LPR/LPD print job.
- **Print Trailer Page:** Check this box to have the trailer page printer at the end of each LPR/LPD print job.
- **Supress Blank Page:** Check this box to eliminate the blank page that often occurs at the end of the LPR/LPD print job (and after the trailer page if enabled).

When configuring the LPR host (such as the UNIX server or even another Windows PC), two pieces of information will be required: 1) the IP address of the Thin Client (which can be found on the Network Status | IPconfig option) and 2) the Que Name (sometimes referred to as the printer port or printer name).



NOTE: REFER TO YOUR NETWORK ADMINISTATOR, SYSTEM ADMINISTRATOR OR MICROSOFT CERTIFIED SYSTEMS ENGINEER FOR ADDITIONAL INFORMATION ON SETTING UP LPR/LPD PRINTING.

SNMP Setup

SNMP is a network inventory and management protocol used in large enterprise networks to determine what devices are connected into their network. Enter on this screen the device name, location and contact information that will be provided to SNMP applications.

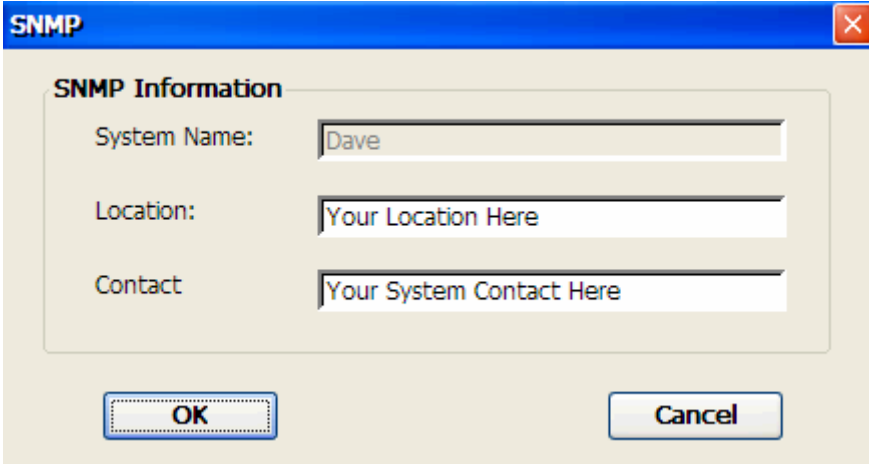

The image shows a dialog box titled "SNMP" with a close button in the top right corner. The dialog box contains a section titled "SNMP Information" with three text input fields. The first field is labeled "System Name:" and contains the text "Dave". The second field is labeled "Location:" and contains the text "Your Location Here". The third field is labeled "Contact" and contains the text "Your System Contact Here". At the bottom of the dialog box, there are two buttons: "OK" and "Cancel".

Field Label	Value
System Name:	Dave
Location:	Your Location Here
Contact	Your System Contact Here

ICA Global Settings

Use the screens in this section to configure the global settings required for an ICA connection to a Citrix Metaframe server.



NOTE: REFER TO THE CLIENT FOR WINDOWS CE WINDOWS-BASED TERMINALS ADMINISTRATOR'S GUIDE LOCATED ON THE UTILITY CD FOR DETAILS ON SELECTING THE GLOBAL ICA CONFIGURATION OPTIONS. THIS MANUAL IS ALSO AVAILABLE FROM THE HELP MENU OF THE I-O CONFIGURATION UTILITY.



NOTE: REFER TO YOUR CITRIX CERTIFIED NETWORK ENGINEER FOR ASSISTANCE IN SETTING UP THE ICA CLIENT AND GLOBAL SETTINGS.

122-Keyboard

If an I-O 122-Key 5250 Style Thin Client Keyboard is being used with the thin client, use this screen to enable the 122 keyboard layout for display terminal emulation connections.

Selecting this option will create keyboard macros in each terminal emulation session. Removing the selection will delete the keyboard macros.



NOTE: FOR DETAILS ON THE USE OF THE KEYBOARD MACROS IN THE TERMINAL EMULATION SESSIONS, REFER TO THE TERMINAL EMULATION USER'S GUIDE.

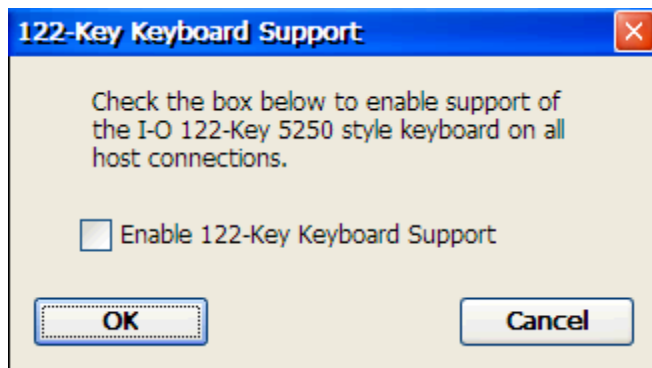

USB Storage

USB storage devices such as pen drives, thumb drives, are used to store e-mail attachments. If a large amount of e-mail attachments are to be stored, it is recommended that this storage option be used. (There is a limited amount of kFlash that is available which should be reserved for storage of cookies, settings, etc.) By default, USB storage is enabled.



Troubleshooting

This chapter contains basic solutions to problems you may encounter while using the thin client. If a problem persists even after you implement the solutions provided here, please contact your in-house network administrator, your Microsoft Certified System Engineer or Citrix Certified Administrator or I-O Corporation, 1490 North 2200 West, Suite 100, Salt Lake City, UT 84116 at 801-973-6767, visit our web site www.iocorp.com, or e-mail support@iocorp.com.



NOTE: INSTALLATION AND OPERATIONAL QUESTIONS PERTAINING TO NETWORKING, MICROSOFT WINDOWS TERMINAL SERVICES AND RDP CONNECTIONS, CITRIX METAFRAME AND ICA CONNECTIONS ARE TO BE REFERRED TO YOUR NETWORK SPECIALIST, MICROSOFT CERTIFIED SYSTEM ENGINEER, OR CITRIX CERTIFIED ADMINISTRATOR. I-O CORPORATION WILL ONLY ANSWER QUESTIONS ABOUT THE THIN CLIENT CONFIGURATION PARAMETERS ENTERED IN THE THIN CLIENT.

Please have the following information available when calling for assistance:

- Model number
- Version number of firmware
- Version number of the I-O Configuration Utility
- Type of keyboard
- Serial number of the thin client (found on the back of the logic unit)
- Date of purchase
- Version of operating system on the IBM host system
- Model number of printer (if attached)
- Concise description of problem
- Summary of events and actions that occurred just prior to the failure

General Troubleshooting

<i>Problem</i>	<i>Solution</i>
<ul style="list-style-type: none"> • The Power-LED on front panel does not glow when the thin client is switched on. 	<ul style="list-style-type: none"> ✓ Ensure that the AC Transformer is connected to the AC inlet of the thin client. ✓ Ensure that the power cord is plugged into an wall outlet.
<ul style="list-style-type: none"> • There is no display, though the power-indicating LED glows. 	<ul style="list-style-type: none"> ✓ Ensure that the power cord of the display unit is connected and that the power supply is switched on. ✓ Ensure that the video cable is properly connected.
<ul style="list-style-type: none"> • The mouse does not work when the thin client is switched on. 	<ul style="list-style-type: none"> ✓ Ensure that the mouse is plugged into the PS/2 Mouse or USB port on the rear panel.
<ul style="list-style-type: none"> • The keyboard does not work when the thin client is switched on. 	<ul style="list-style-type: none"> ✓ Ensure that the keyboard is plugged into the PS/2 keyboard or USB port on the rear panel.
<ul style="list-style-type: none"> • If there is an interruption in the external power supply, the thin client does not automatically restart when power supply resumes. 	<ul style="list-style-type: none"> ✓ You must press the On/Off switch on the front panel to restart the thin client after an interruption in external power supply.

- The display is not satisfactory.
 - ✓ Check whether your display unit supports the display setting selected. If it does not, perform one of the following procedures:
 - ✓ Request your system administrator to change the display setting of the thin client using the inControl for Terminals utility.
 - ✓ Connect a display unit that supports the selected setting. Change the display setting to 800 x 600 @ 60 Hz. Disconnect the display unit and reconnect the previous display unit.

- Mouse movement is out of control.
 - ✓ Switch off and restart the system. Do not move the mouse until the Terminal Connection Manager is displayed.

- A message "Insufficient Memory to Run application" is displayed.
 - ✓ This happens when multiple connections are active. The system displays a list of all open programs. Select those that can be closed. This will free some memory and allow active applications to run.
 - ✓ Increase the memory available for programs in the Control Panel | System option.

- The parallel printer connected to the thin client does not print.
 - ✓ Check whether the protocol you are using supports printing.
 - ✓ Ensure that the printer is plugged into the proper power outlet and switched on.
 - ✓ Ensure that the printer is online.
 - ✓ Check the connection between the printer and the thin client.
 - ✓ Ensure that the printer is properly configured in the application's print manager function.
 - ✓ Ensure that the printer has not been 'paused'.

- The serial printer connected to the thin client does not print.
 - ✓ Ensure that the printer is plugged into the proper power outlet.
 - ✓ Ensure that the printer is switched on and online.
 - ✓ Check the connection between the printer and the thin client.
 - ✓ Ensure that thin client-serial-port and the printer are identically configured. They must use the same handshaking protocol. Refer to your printer manual for information about printing from a serial connection.
 - ✓ Ensure that the printer is configured properly in the application's print manager and that it has not been paused.

- The I-O Configuration Utility Screen went blank while doing a firmware upgrade.
 - ✓ If you were to switch to a different window while the I-O Configuration Utility is doing an upgrade and return to the I-O Configuration Utility and find that the screens are blank, do not show the proper information, or are not being updated as the firmware file is being downloaded to the thin client, this is a Microsoft Windows screen refresh problem. Also, the Windows Task Manager may show that the I-O Configuration Utility is not responding. The I-O Configuration Utility is working in the background and will complete the process properly – Windows has

not updated the screens properly but will when the I-O Configuration Utility completes the download.



CAUTION: IF THIS OCCURS DURING A FIRMWARE UPGRADE, DO NOT END THE TASK. ALLOW THE TASK TO CONTINUE TO RUN – IT IS WORKING IN THE BACKGROUND. ENDING THE TASK DURING A FIRMWARE UPGRADE WILL CORRUPT THE FLASH ON THE THIN CLIENT REQUIRING IT TO BE RETURNED FOR REPAIR.

- The security password has been lost.
 - ✓ Restore a previously saved configuration where the security feature was not activated.
 - ✓ Restore factory defaults.
 - ✓ Contact technical support.

- The Ping function continues to run filling the screen with ping responses.
 - ✓ Press and hold the ESC key for a couple of seconds if the ping response does not stop after four responses.

- There is a status line, but no sign on screen, and there is a block cursor in the upper left corner of the screen
 - ✓ Check the following:
 - Verify the IP address on both the host and thin client coincides.
 - Make certain that no other device on the network is using the same IP addresses as the host and display station.
 - Answer any host messages.
 - Vary off the device and end the Telnet session:
 1. To vary off a device, on the AS/400, at a command line, enter “wrkdevd [device name]”, press ENTER. Select the work with status option, then the vary off option.
 2. To end the Telnet sessions, on the AS/400 at a command line, enter “netstat”, select the Work with TCP/IP Connection Status option, press ENTER. (You may also use the “wrktcpsts *dev [device name]” command.) Scroll until entries for the IP address of the thin client is found. Select the option to end the session.

IBM Error Codes

This section applies to the TeemTalk 5250 display connection.

IBM error codes are generated by the host system when an error occurs in the application being run, such as using the wrong command key, making the wrong selection from a menu, and so on.

When an error occurs, the keyboard lock and the inhibit indicator “ X ”, appears and remains in the status line. You will also see a four-digit system error code in the center of the status line.

To recover from an error, press Reset and continue to input information. If you cannot recover from an error condition, contact the system operator.

Error Code	Solution
-------------------	-----------------

- 0000
 - ✓ The Help key was pressed. Either no error code was displayed, or the error was issued by a program that does not support the Help key.
 - Press RESET and continue entering information, or refer to previous error and perform action required.

- 0001
 - ✓ The host or remote workstation control unit is slower than the keystrokes entered. The last character you entered was not recognized.
 - Press RESET and continue entering data.

- 0002
 - ✓ The host system or remote workstation control unite received an invalid key code.
 - Press RESET and continue entering data. If the error still occurs, report the problem to your system administrator.

- 0003
 - ✓ You pressed an invalid key after pressing and hold the <Alt> key.
 - Press RESET.

- 0004
 - ✓ Your attempted to enter data into a field that does not allow keyboard input.
 - Press RESET

- 0005
 - ✓ You attempted to enter data when the cursor was not in an input field. Data cannot be entered in a protected area of the display.
 - ✓ Press RESET. Move the cursor to a valid input field.

- 0006
 - ✓ After pressing the SysReq/Attn key, and before pressing the <Enter> key or the RESET key, you pressed an invalid key.
 - Press RESET.

- 0007
 - ✓ At least one field on the display requires that you enter data before the display can be changed or moved. (The cursor goes to the first character position of the first mandatory-entry field.)
 - Press RESET and enter the required data.

- 0008
 - ✓ Non-alphabetic data was attempted to be entered into an alphabetic field. Valid characters are A-Z, a blank, a comma, a period, and a hyphen.
 - Press RESET and use valid characters.

- 0009
 - ✓ Non-numeric data was attempted to be entered into a numeric only field. Valid characters are 0-9, a blank, a comma, a period, and a hyphen.
 - Press RESET and use valid characters.
- 0010
 - ✓ Data was entered into a field that will only accept signed numeric data. Valid characters are 0-9.
 - Press RESET and use valid characters.
- 0011
 - ✓ Data was entered into the last position of a signed numeric field.
 - Press RESET and make sure that the data is correct. Exit the field by using the Field -, Field +, or Field Exit keys.
- 0012
 - ✓ The cursor is either in the last position of the field or there are no spaces in the field.
 - Press RESET. Correct the field, if necessary. The insert key may not be used to change data or to enter the last character into the field.
- 0013
 - ✓ After pressing the Insert key, you attempted to leave a field.
 - Press RESET.
- 0014
 - ✓ A key function was pressed that moves the cursor out of the field. However, the requirements of the mandatory-fill field have not been met. (Mandatory-fill fields must be filled completely or left blank.)
 - Press RESET and enter data to fill the entire field, or move the cursor to the start of the field and use the Field -, Field +, or Field Exit keys to blank out the entire field.
- 0015
 - ✓ Data was entered in the self-check field. The number and the digit you just entered do not correspond.
 - Press RESET and verify numbers entered. If numbers are valid, but error still occurs, contact your systems administrator.
- 0016
 - ✓ The Field – key was pressed, but you are not in a numeric field.
 - Press RESET and continue to enter data. Press Field Exit to blank the field.

- 0017
 - ✓ Field -, Field +, or the Field Exit key have been pressed, but the requirements for this field have not been met. You must fill this field completely or exit the first position of the field.
 - Press RESET and enter data to the end of field or move the cursor to the start of the field and use one of the field keys to blank out the field.

- 0018
 - ✓ A data key was used instead of a non-data key.
 - Press RESET and use a non-data key such as a FIELD EXIT key or an arrow key to leave this field.

- 0019
 - ✓ The Dup key was pressed, and is not permitted in this field.
 - Press RESET and continue.

- 0020
 - ✓ An invalid key was pressed.
 - Press RESET and continue by pressing the FIELD +, FIELD -, or FIELD EXIT key.

- 0021
 - ✓ The cursor is positioned in a mandatory enter field. Data must be entered before you can exit the field by pressing the Field -, Field +, or Field Exit key.
 - Press RESET and enter the required data.

- 0022
 - ✓ A system error occurred when using the Insert or Delete key.
 - Press RESET. Verify if the insert or delete function was done properly. If not, correct the field.

- 0023
 - ✓ The Hex key was pressed, but the keys following were not A-F, or 0-9. This error also occurs when a hexadecimal code is used in a numeric-only, signed numeric, alpha only, or feature I/O field.
 - Press RESET and continue.

- 0024
 - ✓ A non-numeric value was entered in a numeric-only field.
 - Press RESET and continue.

- 0026
 - ✓ The Field – key was pressed to exit a numeric-only field, but last position of the field is not numeric.
 - Press RESET and correct the last position of the field.

- 0027
 - ✓ A key was pressed not used by the display module
 - ✓ Press RESET and continue using valid keys.

- 0029
 - ✓ Second key pressed during the diacritic mark key function was not a valid combination.
 - Press RESET and enter a valid combination.

- 0040
 - ✓ The “Data Set Ready” line is inactive, and should be active.
 - ✓ Recovery must be made at the remote control unit.

- 0042
 - ✓ The “Receive Clock” signal failed.
 - ✓ Recovery must be made at the remote control unit.

- 0043
 - ✓ The “Data Set Ready” line is active and should be inactive.
 - Recovery must be made at the remote control unit.

- 0044
 - ✓ The 30-second communications time-out expired with out valid data received.
 - Recovery must be made at the remote control unit.

- 0045
 - ✓ “Data Set Ready” will not activate.
 - Recovery must be made at the remote control unit.

- 0050
 - ✓ Either the “Clear to Send” line was inactive while the “Request to Send “ line was active or the “Clear to Send” line was active while the “Request to Send” line was inactive.
 - Recovery must be made at the remote control unit.

- 0051
 - ✓ The transmit clock signal failed during a transmit operation.
 - ✓ Recovery must be made at the remote control unit.

- 0052
 - ✓ The remote control unit detected an error.
 - Recovery must be made at the remote control unit.

- 0054
 - ✓ The remote control unit received invalid commands from the system during communication.
 - Recovery must be made at the remote control unit.

-
- 0072
 - ✓ The key pressed is not valid in the current area of the screen.
 - Recovery must be made at the remote control unit.

 - 0097
 - ✓ On-line verification test not supported by the host program were trying to run.
 - Press RESET and continue to use display module with out performing the verification tests

 - 0099
 - ✓ An error occurred before, after, or during the sign-on.
 - Press RESET and if error occurs again, contact your system administrator.

Firmware Upgrade Process

Periodically new firmware is made available that contains enhancements and corrections. This firmware may be downloaded using the following process:

1. Using your Web browser, navigate to <ftp://ftp.iocorp.com>.
2. Open the Displays_Ethernet | TC5000 folder
3. Download to a temporary directory on your PC the Ftc5000???.zip file that contains the desired firmware version. The ??? will be the version number. It is suggested that you download the latest firmware version.



NOTE: THE README.TXT FILE CONTAINS UP TO DATE INSTRUCTIONS ON OBTAINING THE LATEST FIRMWARE UPDATES AND I-O CONFIGURATION UTILITY



TIP: IT IS HIGHLY SUGGESTED THAT WHEN YOU UPGRADE THE FIRMWARE, THAT YOU ALSO UPGRADE THE I-O CONFIGURATION UTILITY AT THE SAME TIME. IT WILL BE FOUND IN THE CONFIGURATION UTILITY DIRECTORY. GENERALLY YOU WILL WANT TO USE THE MOST RECENT VERSION OF THE I-O CONFIGURATION UTILITY.

4. On the PC, extract the firmware file from the zip file, and move the firmware file to the directory where the I-O Configuration Utility was installed. (After the upgrade is complete, delete the zip file.)
5. On the thin client, sign off all connections.
6. Start the I-O Configuration Utility.
7. In the List of Devices, **highlight** the desired thin client to be upgraded.

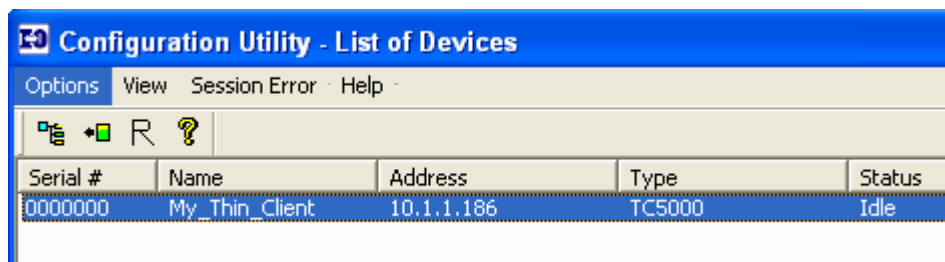

8. Select the **Options Menu | Firmware Update** menu item.

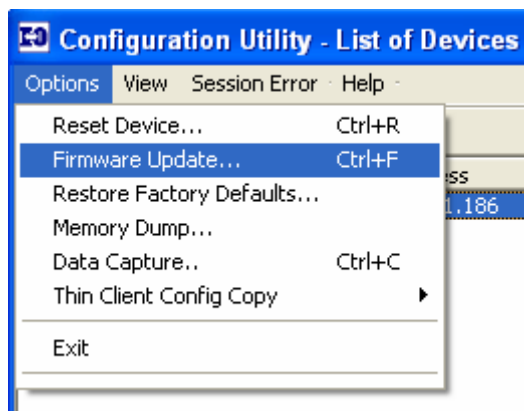

9. Use the Browse button to browse the directory to find the firmware file. It will be called NK.BIN. Click **OK** to cause the firmware download to begin

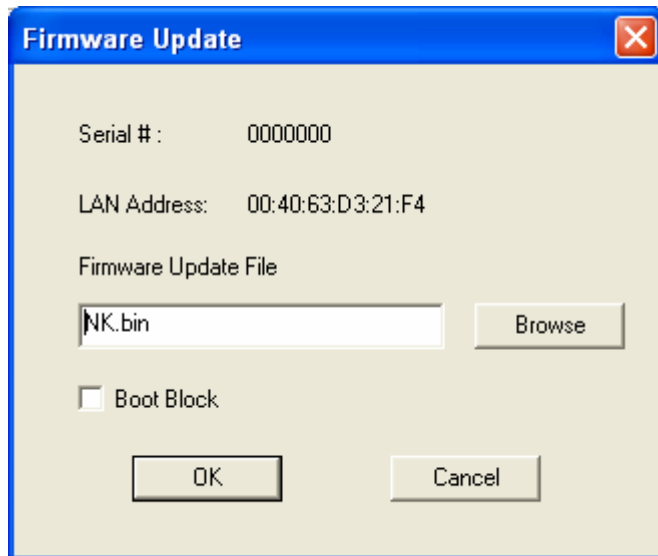

NOTE: DO NOT CHECK THE BOOT BLOCK BOX.

- A message will appear on the screen indicating that the download process is progressing. Be patient, this process takes several minutes.

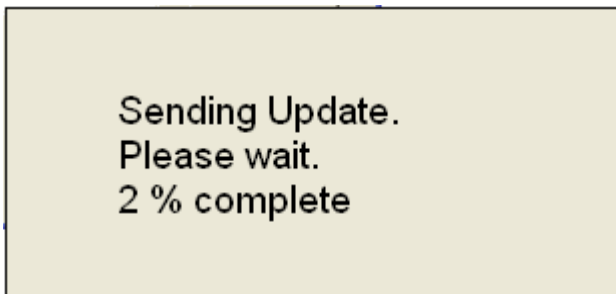

NOTE: DON'T BE CONCERNED IF THE UPDATE STATUS INDICATOR STAYS AT 99 FOR 30 SECONDS OR SO – THE PROGRAM IS DOING SOME WORK IN THE BACKGROUND.

- On the thin client a message will appear informing the user that an update is in progress.

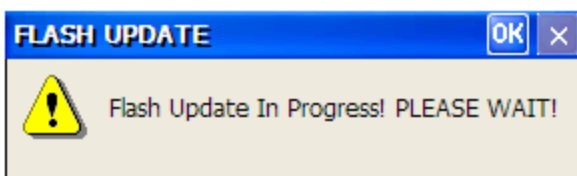

CAUTION: DO NOT TURN OFF THE THIN CLIENT DURING THIS PROCESS. DOING SO WILL CORRUPT THE FLASH AND REQUIRE THE UNIT TO BE RETURNED FOR REPAIR.

- When the firmware download is complete, you will be prompted to reset the thin client. Click **Yes..**



13. At this point the thin client will go through a restart process and will present the Connection Manager screen when restarted.



NOTE: OCCASIONALLY IT MAY BE NECESSARY TO CYCLE THE POWER TO THE DISPLAY STATION FOR THE NEW FIRMWARE TO BE RECOGNIZED. IN SOME RARE CIRCUMSTANCES, IT MAY BE NECESSARY TO RESTORE FACTORY DEFAULTS TO GET THE NEW FIRMWARE TO BE RECOGNIZED.

I-O Configuration Utility Upgrade Process

Periodically a new version of the I-O Configuration Utility is made available that contains enhancements and corrections. This software may be downloaded using the following process:

1. Using your Web browser, navigate to <ftp://ftp.iocorp.com>.
2. Open the Configuration_Utility folder
3. Download to a temporary directory on your PC the zip file that contains the latest version of the I-O Configuration Utility (some of the files may be self-extracting zip files and will have an extension of exe). Look for a file in the format of IOCU???.zip. The ??? will be the version number.



NOTE: THE README.TXT FILE CONTAINS UP TO DATE INSTRUCTIONS ON OBTAINING THE LATEST I-O CONFIGURATION UTILITY AND FIRMWARE UPDATES.



TIP: THE I-O CONFIGURATION UTILITY IS BACKWARD COMPATIBLE AND WILL MANAGE DISPLAY STATIONS, PRINT SERVERS AND IP CONTROLLERS USING OLDER VERSIONS OF FIRMWARE.

4. Extract the firmware file from the zip file. (After the upgrade is complete, delete the zip file.)
5. From within the temporary directory, run the SETUP.EXE file.
6. Follow the on-screen prompts.

Uninstalling the I-O Configuration Utility

The I-O Configuration Utility may be uninstalled using Microsoft's Add/Remove Programs process.

1. Click **START | SETTINGS | CONTROL PANEL**
2. Select the **Add/Remove** Programs icon.
3. Scroll to the I-O Configuration Utility entry and take the remove option.
4. Follow the on-screen prompts.

Saving / Restoring the Thin Client's Configuration

Through the I-O Configuration Utility, it is possible to save a copy of the thin client's configuration file. This file can be used for the following purposes:

- Re-apply the configuration to the thin client after factory defaults have been restored – eliminates having to remember all the settings for a specific thin client.
- Copy a master configuration to newly installed thin clients – eliminates the time of visiting each thin client and setting it up.



CAUTION: CARE SHOULD BE TAKEN IN CREATING A MASTER CONFIGURATION FILE. IT WILL CONTAIN ALL THIN CLIENT CONFIGURATION PARAMETERS. THIS COULD CAUSE PROBLEMS IF STATIC IP ADDRESSES ARE USED IN THE LAN. A MASTER IP ADDRESS SHOULD BE USED WHEN SAVING THE CONFIGURATION FILE. THEN AFTER THE MASTER CONFIGURATION IS BEING SENT TO ANOTHER THIN CLIENT, THE IP ADDRESS OF THE TARGET THIN CLIENT MUST BE CHANGED.

Saving a Configuration

1. **Start** the I-O Configuration Utility.
2. On the List of Devices screen, **highlight** the desired thin client

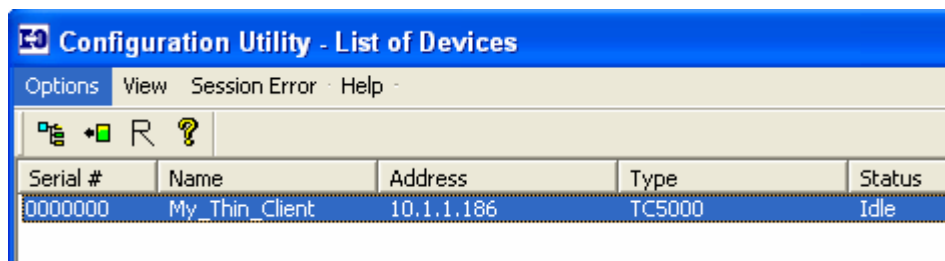

3. On the Options menu, select the **Thin Client Config Copy** option, then select **Retrieve Configuration**.

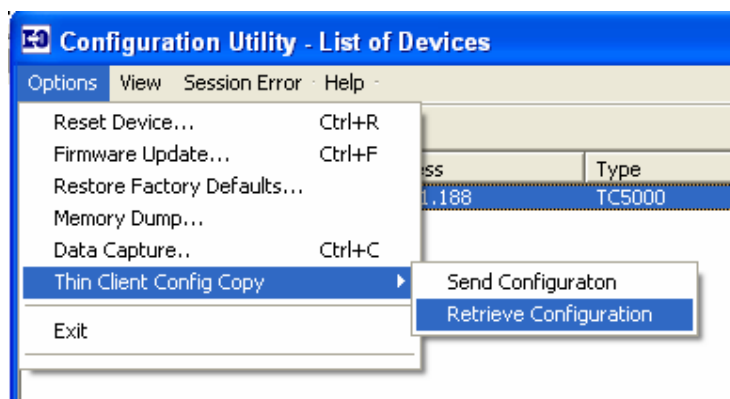

4. Enter the name for the file, and click **OK**. You may need to browse to the desired directory to save the configuration files in. Configuration files will have a file extension of .cfg.

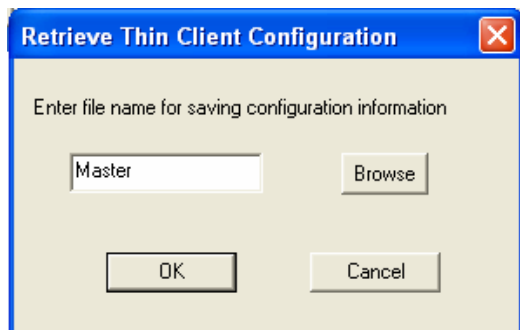

5. The configuration of the thin client will then be saved on the PC.

Restoring a Configuration

1. **Start** the I-O Configuration Utility.
2. On the List of Devices screen, **highlight** the desired thin client

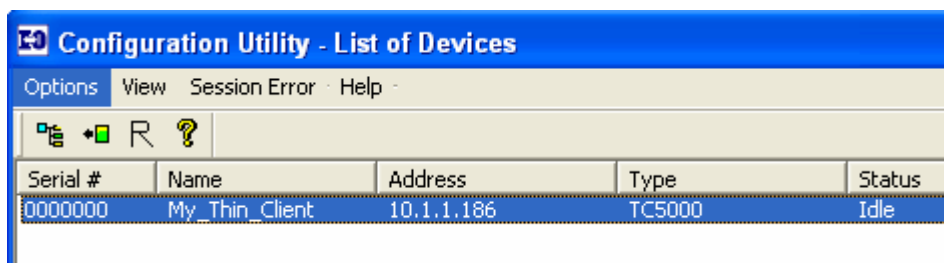

3. On the Options menu, select the **Thin Client Config Copy** option, then select **Send Configuration**.

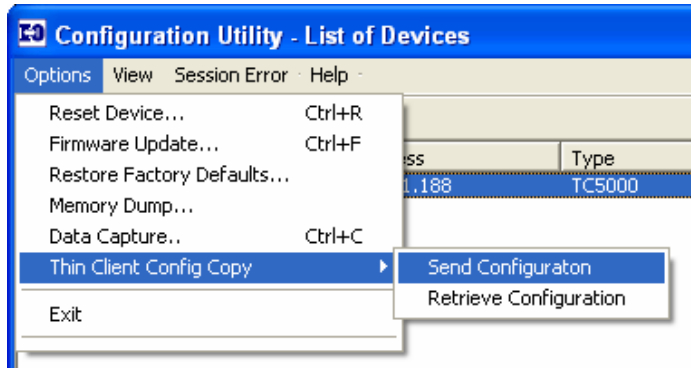

4. Enter the name of the saved configuration file. You may need to use the Browse feature to find the configuration file. Click **OK**.

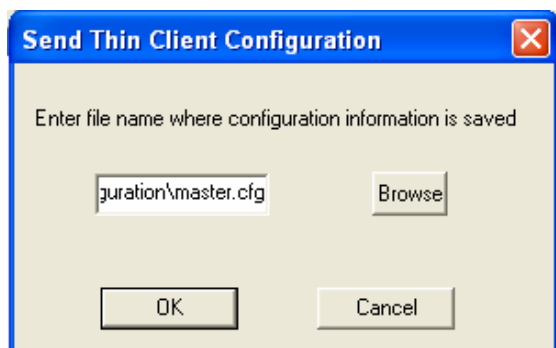

5. A message will appear alerting you that the configuration file is being sent to the thin client.

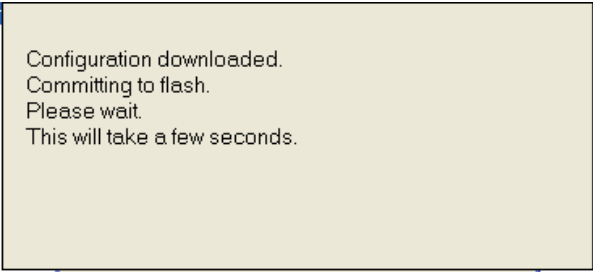

Configuration downloaded.
Committing to flash.
Please wait.
This will take a few seconds.

6. On the thin client, a brief message will appear alerting the user that the configuration file is being downloaded. After a few seconds, the thin client will restart. The new configuration will be applied.

Restoring Factory Defaults

The purpose of restoring factory defaults is to clear all configuration settings and return the thin client to its factory defaults. There are two methods of restoring factory defaults.

- During the boot up process
- From the Terminal Properties | General Tab



CAUTION: RESETTING THE THIN CLIENT TO FACTORY DEFAULTS WILL CLEAR ALL CONNECTION ENTRIES AND CONFIGURATION SETTINGS IN THE THIN CLIENT. MAKE CERTAIN YOU REALLY WANT TO DO THIS PROCESS BEFORE PROCEEDING. (IT MIGHT BE WISE TO COPY THE THIN CLIENT'S CONFIGURATION PRIOR TO RESETTING THE FACTORY DEFAULTS.)

Boot Up Process

1. When the thin client is initially being powered up, press the **F7** key several times immediately after the I-O Splash screen has cleared.
2. The Setup Wizard will then begin.

General Tab Process

1. From the Connection Manager, press the **F2** key to display the Terminal Property's General Tab
2. Check the **Reset the terminal to factory-default property settings** box.

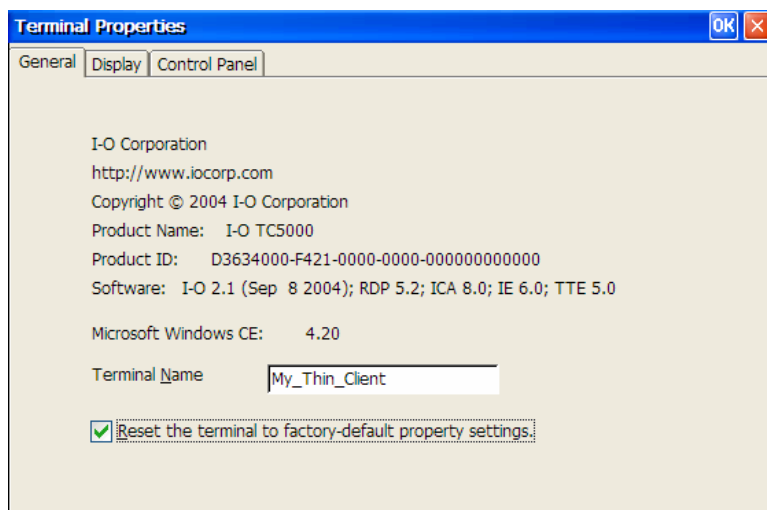

3. The System Setting Change screen will appear. Click the **Yes** button to confirm that the factory defaults will be restore when the thin client is reset.

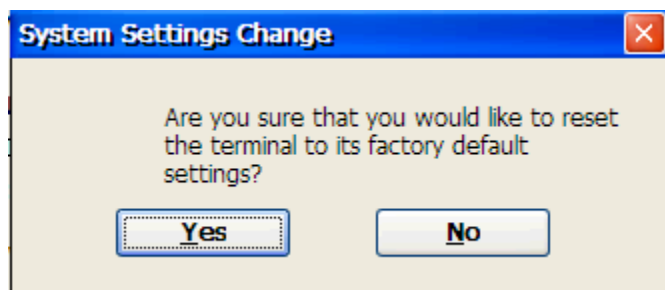

- Click the **OK** button on the title bar (on the upper right hand corner of the screen)



- Respond to the message by click **Yes**.

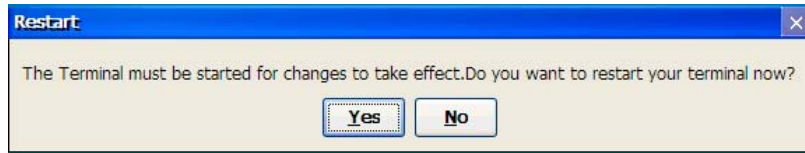

- The thin client will restart and display the Setup Wizard.

Accessing the Motherboard's Startup Processes

The motherboard's startup processes include the following:

- Initial bootup sequence – press the ESC key immediately when you see the message “Press <ESC> key to display network boot option menu”. This option should be set to Option 4 – Boot according to BIOS setting.
- BIOS Settings – press and hold the ESC key immediately upon bootup when you see the motherboard splash screen. The CMOS Setup Utility will be presented.

Microsoft Software License

MICROSOFT® WINDOWS® CE OPERATING SYSTEM FOR WINDOWS- BASED TERMINAL DEVICES

IMPORTANT—READ CAREFULLY: This End User License Agreement (“EULA”) is a legal agreement between you (either an individual or a single entity) and the manufacturer (“Manufacturer”) of the special purpose computing device (“SYSTEM”) you acquired which includes certain Microsoft software product(s) installed on the SYSTEM and/or included in the SYSTEM package (“SOFTWARE”). The SOFTWARE includes computer software, the associated media, any printed materials, and any “online” or electronic documentation. By installing, copying or otherwise using the SOFTWARE, you agree to be bound by the terms of this EULA. If you do not agree to the terms of this EULA, Manufacturer and Microsoft Licensing, Inc. (“MS”) are unwilling to license the SOFTWARE to you. In such event, you may not use or copy the SOFTWARE, and you should promptly contact Manufacturer for instructions on return of the unused product(s) for a refund.

SOFTWARE LICENSE

The **SOFTWARE** is protected by copyright laws and international copyright treaties, as well as other intellectual property laws and treaties. The SOFTWARE is licensed, not sold.

1. GRANT OF LICENSE. **SOFTWARE** includes software already installed on the SYSTEM (“SYSTEM Software”) and, if included in the SYSTEM package, software contained on the CD-ROM disk and/or floppy disk(s) labeled “Desktop Software for Microsoft Windows CE” (“Desktop Software”). This EULA grants you the following rights to the SOFTWARE:

- **SYSTEM Software.** You may use the SYSTEM Software only as installed in the SYSTEM.
- **Desktop Software.** Desktop Software might not be included with your SYSTEM. If Desktop Software is included with your SYSTEM, you may install and use the component(s) of the Desktop Software in accordance with the terms of the end user license agreement provided with such component(s). In the absence of a separate end user license agreement for particular component(s) of the Desktop Software, you may install and use only one (1) copy of such component(s) on a single computer with which you use the SYSTEM.
- **Use of Windows CE Operating System for Windows-Based Terminal Devices with Microsoft Windows NT Server, Terminal Server Edition.** If the SOFTWARE is Windows CE operating system for Windows-Based Terminal devices, the following special provisions apply. In order to use the SYSTEM in connection with Windows NT Server, Terminal Server Edition, you must possess (1) a Client Access License for Windows NT Server, Terminal Server Edition and (2) either an end user license for Windows NT Workstation or a Terminal Services Client Access License (please refer to the end user license agreement for Windows NT Server, Terminal Server Edition for additional information).
- **Back-up Copy.** If Manufacturer has not included a back-up copy of the SYSTEM Software with the SYSTEM, you may make a single back-up copy of the SYSTEM Software. You may use the back-up copy solely for archival purposes.

2. DESCRIPTION OF OTHER RIGHTS AND LIMITATIONS.

- **Speech/Handwriting Recognition.** If the SYSTEM Software includes speech and/or handwriting recognition component(s), you should understand that speech and handwriting recognition are inherently statistical processes; that recognition errors are inherent in the processes; that it is your responsibility to provide for handling such errors and to monitor the recognition processes and correct any errors. Neither Manufacturer nor its suppliers shall be liable for any damages arising out of errors in the speech and handwriting recognition processes.

- **Limitations on Reverse Engineering, Decompilation and Disassembly.** You may not reverse engineer, decompile, or disassemble the SYSTEM Software, except and only to the extent that such activity is expressly permitted by applicable law notwithstanding this limitation.
- **Single SYSTEM.** The SYSTEM Software is licensed with the SYSTEM as a single integrated product. The SYSTEM Software installed in Read Only Memory (“ROM”) of the SYSTEM may only be used as part of the SYSTEM.
- **Single EULA.** The package for the SYSTEM Software may contain multiple versions of this EULA, such as multiple translations and/or multiple media versions (e.g., in the user documentation and in the software). Even if you receive multiple versions of the EULA, you are licensed to use only one (1) copy of the SYSTEM Software.
- **Rental.** You may not rent or lease the SOFTWARE.
- **Software Transfer.** You may permanently transfer all of your rights under this EULA only as part of a sale or transfer of the SYSTEM, provided you retain no copies, you transfer all of the SOFTWARE (including all component parts, the media, any upgrades or backup copies, this EULA and, if applicable, the Certificate(s) of Authenticity), and the recipient agrees to the terms of this EULA. If the SOFTWARE is an upgrade, any transfer must include all prior versions of the

SOFTWARE.

- **Termination.** Without prejudice to any other rights, Manufacturer or MS may terminate this EULA if you fail to comply with the terms and conditions of this EULA. In such event, you must destroy all copies of the SOFTWARE and all of its component parts.

3. UPGRADES AND RECOVERY MEDIA.

- If the SYSTEM Software and this EULA are provided separate from the SYSTEM by Manufacturer and the SYSTEM Software is on a ROM chip, CD ROM disk(s) or floppy disk(s), and labeled “For ROM Upgrade Purposes Only” (“ROM Upgrade”), you may install one copy of the ROM Upgrade onto the SYSTEM as a replacement copy for the SYSTEM Software originally installed on the SYSTEM and use it in accordance with Section 1 of this EULA. You may also install additional copies of the ROM Upgrade as replacement copies onto additional SYSTEMS which are the same brand and model as the SYSTEM and contain a duly licensed copy of the same version and language release of the SOFTWARE (“ADDITIONAL SYSTEMS”), provided that (1) Manufacturer has supplied a corresponding serialized sticker for each additional copy of the ROM Upgrade, and (2) you affix a serialized sticker per Manufacturer’s instructions for each unit of ROM Upgrade you install.
- If the SYSTEM SOFTWARE is provided by Manufacturer on separate media and labeled as “Recovery Media”, you may not make a copy of the SOFTWARE as described in Section 1 for archival purposes. Instead, you may use the Recovery Media solely to restore or reinstall the same version and language release of the SOFTWARE as originally installed on the SYSTEM and thereafter use the SOFTWARE as restored or reinstalled in accordance with Section 1 of this EULA. A single unit of Recovery Media may be used by you to restore or reinstall the SOFTWARE on ADDITIONAL SYSTEMS.

4. COPYRIGHT. All title and copyrights in and to the SOFTWARE (including but not limited to any images, photographs, animations, video, audio, music, text and “applets,” incorporated into the SOFTWARE), the accompanying printed materials, and any copies of the SOFTWARE, are owned by MS or its suppliers (including Microsoft Corporation). You may not copy the printed materials accompanying the SOFTWARE. All rights not specifically granted under this EULA are reserved by MS and its suppliers (including Microsoft Corporation).

5. PRODUCT SUPPORT. Product support for the SOFTWARE is not provided by MS, its parent corporation, Microsoft Corporation, or their affiliates or subsidiaries. For product support, please refer to Manufacturer’s support number provided in the documentation for the SYSTEM. Should you have any questions concerning this EULA, or if you desire to contact Manufacturer for any other reason, please refer to the address provided in the documentation for the SYSTEM.

6. EXPORT RESTRICTIONS. You agree that you will not export or re-export the SOFTWARE to any country, person, or entity subject to U.S. export restrictions. You specifically agree not to export or re-export the SOFTWARE: (i) to any country to which the U.S. has embargoed or restricted the export of goods or services, which as of March 1998 include, but are not necessarily limited to Cuba, Iran, Iraq,

Libya, North Korea, Sudan and Syria, or to any national of any such country, wherever located, who intends to transmit or transport the products back to such country; (ii) to any person or entity who you know or have reason to know will utilize the SOFTWARE or portion thereof in the design, development or production of nuclear, chemical or biological weapons; or (iii) to any person or entity who has been prohibited from participating in U.S. export transactions by any federal agency of the U.S. government.

If SOFTWARE is labeled “North America Only Version” above, on the Product Identification Card, or on the SOFTWARE packaging or other written materials, then the following applies: The SOFTWARE is intended for distribution only in the United States, its territories and possessions (including Puerto Rico, Guam, and U.S. Virgin Islands) and Canada. Export of the SOFTWARE from the United States is regulated under “EI controls” of the Export Administration Regulations (EAR, 15 CFR 730-744) of the U.S. Commerce Department, Bureau of Export Administration (BXA). A license is required to export the SOFTWARE outside the United States or Canada. You agree that you will not directly or indirectly, export or re-export the SOFTWARE (or portions thereof) to any country, other than Canada, or to any person or entity subject to U.S. export restrictions without first obtaining a Commerce Department export license. You warrant and represent that neither the BXA nor any other U.S. federal agency has suspended, revoked or denied your export privileges.

7. NOTE ON JAVA SUPPORT. The SYSTEM Software may contain support for programs written in Java. Java technology is not fault tolerant and is not designed, manufactured, or intended for use or resale as on-line control equipment in hazardous environments requiring fail-safe performance, such as in the operation of nuclear facilities, aircraft navigation or communication systems, air traffic control, direct life support machines, or weapons systems, in which the failure of Java technology could lead directly to death, personal injury, or severe physical or environmental damage.

8. LIMITED WARRANTY.

- **Limited Warranty.** Manufacturer warrants that the SOFTWARE will perform substantially in accordance with the accompanying written materials for a period of ninety (90) days from the date of receipt. Any implied warranties on the SOFTWARE are limited to ninety (90) days. Some states/jurisdictions do not allow limitations on duration of an implied warranty, so the above limitation may not apply to you.
- **Customer Remedies.** Manufacturer’s and its suppliers’ entire liability and your exclusive remedy shall be, at Manufacturer’s option, either (a) return of the price paid, or (b) repair or replacement of the SOFTWARE that does not meet the above Limited Warranty and which is returned to Manufacturer with a copy of your receipt. This Limited Warranty is void if failure of the SOFTWARE has resulted from accident, abuse, or misapplication. Any replacement SOFTWARE will be warranted for the remainder of the original warranty period or thirty (30) days, whichever is longer.
- **No Other Warranties.** EXCEPT AS EXPRESSLY PROVIDED IN THE LIMITED WARRANTY SECTION ABOVE, THE SOFTWARE IS PROVIDED TO THE END USER “AS IS” WITHOUT WARRANTY OF ANY KIND, EITHER EXPRESSED OR IMPLIED, INCLUDING, BUT NOT LIMITED TO, WARRANTIES OF NON-INFRINGEMENT, MERCHANTABILITY, AND/OR FITNESS FOR A PARTICULAR PURPOSE. THE ENTIRE RISK OF THE QUALITY AND PERFORMANCE OF THE SOFTWARE IS WITH YOU.
- **No Liability for Consequential Damages.** MANUFACTURER OR MANUFACTURER’S SUPPLIERS, INCLUDING MS AND ITS SUPPLIERS, SHALL NOT BE HELD TO ANY LIABILITY FOR ANY DAMAGES SUFFERED OR INCURRED BY THE END USER (INCLUDING, BUT NOT LIMITED TO, GENERAL, SPECIAL, CONSEQUENTIAL OR INCIDENTAL DAMAGES INCLUDING DAMAGES FOR LOSS OF BUSINESS PROFITS, BUSINESS INTERRUPTION, LOSS OF BUSINESS INFORMATION AND THE LIKE), ARISING FROM OR IN CONNECTION WITH THE DELIVERY, USE OR PERFORMANCE OF THE SOFTWARE.

If you acquired this EULA in the United States, this EULA is governed by the laws of the State of Washington. If you acquired this EULA in Canada, this EULA is governed by the laws of the Province of Ontario, Canada. Each of the parties hereto irrevocably attorns to the jurisdiction of the courts of the Province of Ontario and further agrees to commence any litigation which may arise hereunder in the courts located in the Judicial District of York, Province of Ontario.

If this EULA was acquired outside the United States, then local law may apply. Should you have any questions concerning this EULA, please contact the Manufacturer of your SYSTEM.

U.S. GOVERNMENT RESTRICTED RIGHTS

The SOFTWARE and documentation are provided with RESTRICTED RIGHTS. Use, duplication, or disclosure by the Government is subject to restrictions as set forth in subparagraph (c)(1)(ii) of the Rights in Technical Data and Computer Software clause at DFARS 252.227-7013 or subparagraphs (c)(1) and (2) of the Commercial Computer Software—Restricted Rights at 48 CFR 52.227-19, as applicable. Manufacturer is Microsoft Corporation/One Microsoft Way/Redmond, WA 98052-6399.

Manufacturer's Warranty & Repair Policy

Manufacturer's Three Year Limited Warranty (United States)

The following warranty applies only to products purchased and operated within the United States.

I-O Corporation (I-O) warrants this product against defects in material and workmanship for a period of three years commencing from date of purchase by the original customer, when operated and maintained in accordance with I-O's published specifications. I-O's liability shall be limited, at its option and expense, to refund to buyer the actual amount paid by buyer or to repair or replace any defective or nonconforming product or part thereof, F.O.B. I-O's authorized repair depot. Buyer may obtain a replacement product by meeting the terms of the I-O Customer On-Site Exchange Repair Policy in effect at the time of the request.

THE EXPRESS WARRANTY SET FORTH ABOVE IS IN LIEU OF ALL OTHER EXPRESS OR IMPLIED WARRANTIES. OTHERWISE, THE PRODUCTS ARE SOLD AS IS WITHOUT FURTHER OBLIGATION OR LIABILITY ON THE PART OF I-O. I-O EXPRESSLY EXCLUDES ANY IMPLIED WARRANTIES OF MERCHANTABILITY AND FITNESS FOR A PARTICULAR PURPOSE.

EXCEPT AS EXPRESSLY SET FORTH HEREIN, IN NO EVENT SHALL I-O BE LIABLE FOR ANY CLAIMS OR DAMAGE ARISING DIRECTLY OR INDIRECTLY FROM THE FURNISHING OR FAILURE TO FURNISH PRODUCTS, SPARE OR REPLACEMENT PARTS, INFORMATION OR SERVICES HEREUNDER. UNDER NO CIRCUMSTANCES SHALL I-O BE LIABLE IN ANY WAY FOR INDIRECT, SPECIAL OR CONSEQUENTIAL DAMAGES, INCLUDING, BUT NOT LIMITED TO LOST BUSINESS OR PROFITS, WHETHER OR NOT FORESEEABLE AND WHETHER OR NOT BASED ON BREACH OF WARRANTY, CONTRACT, OR NEGLIGENCE.

I-O shall not be liable for non-performance or delays hereunder due to causes beyond its control. These shall include, but not be limited to, acts of God, wars, strikes, fires, flood, storm, earthquake, shortages of labor or materials, labor disputes, transportation embargoes, acts of any government or agency thereof.

MODIFICATIONS OR RECONFIGURATION OF THE HARDWARE BY ANYONE OTHER THAN I-O OR I-O'S AUTHORIZED REPAIR FACILITY WILL VOID THIS HARDWARE WARRANTY.

Customer On-Site Exchange Repair Policy

Terms, Conditions, and Limitations
Effective May 1, 1994^a

For products covered by the I-O Corporation (I-O) Manufacturer's Limited Warranty (United States), I-O's Customer On-Site Exchange (COE) Repair Policy provides customers with a replacement unit for a defective product, subject to the following terms and conditions

Call Customer Support

If a product fails, call I-O Customer Support for assistance at (801) 972-1446.

Verify Product Failure

I-O will verify the product serial number, warranty coverage and product failure.

You are responsible for assisting in verifying the product failure.

When I-O Customer Support verifies a product failure they will issue a Return Merchandise Authorization (RMA) number for the failed product.

Replacement Units

Replacement units are shipped from I-O's stock of refurbished units, subject to availability.

Replacement units carry the same warranty as remaining on the original product.

I-O's COE Repair Policy applies only to warranted product failures. Buyer guarantees payment for non-warranted product repairs or replacement.

Buyer will pay reasonable labor and handling charges for each product returned for repair which is found to have no defect.

Return Your Failed Unit

When you return the failed product it must be shipped freight prepaid. Always note the RMA number on the outside of the package.

Install the Replacement Unit

You are responsible for installing the replacement unit.

After receiving the replacement unit please call I-O Customer Support if any assistance is required.

^a I-O reserves the right to change the terms and conditions of this policy without notice.

Manufacturer's Three Year Limited Warranty (International)

The following warranty applies only to products purchased or operated outside the United States.

I-O Corporation (I-O) warrants this product against defects in material and workmanship for a period of three years commencing from date of purchase by the original customer, when operated and maintained in accordance with I-O's published specifications. I-O's liability shall be limited, at its option and expense, to refund to buyer the actual amount paid by buyer or to repair or replace any defective or nonconforming product or part thereof, F.O.B. I-O's authorized repair depot. Buyer may obtain warranty service by meeting the terms of the I-O Return-to-Depot Repair Policy in effect at the time of the request.

THE EXPRESS WARRANTY SET FORTH ABOVE IS IN LIEU OF ALL OTHER EXPRESS OR IMPLIED WARRANTIES. OTHERWISE, THE PRODUCTS ARE SOLD AS IS WITHOUT FURTHER OBLIGATION OR LIABILITY ON THE PART OF I-O. I-O EXPRESSLY EXCLUDES ANY IMPLIED WARRANTIES OF MERCHANTABILITY AND FITNESS FOR A PARTICULAR PURPOSE.

EXCEPT AS EXPRESSLY SET FORTH HEREIN, IN NO EVENT SHALL I-O BE LIABLE FOR ANY CLAIMS OR DAMAGE ARISING DIRECTLY OR INDIRECTLY FROM THE FURNISHING OR FAILURE TO FURNISH PRODUCTS, SPARE OR REPLACEMENT PARTS, INFORMATION OR SERVICES HEREUNDER. UNDER NO CIRCUMSTANCES SHALL I-O BE LIABLE IN ANY WAY FOR INDIRECT, SPECIAL OR CONSEQUENTIAL DAMAGES, INCLUDING, BUT NOT LIMITED TO LOST BUSINESS OR PROFITS, WHETHER OR NOT FORESEEABLE AND WHETHER OR NOT BASED ON BREACH OF WARRANTY, CONTRACT, OR NEGLIGENCE.

I-O shall not be liable for non-performance or delays hereunder due to causes beyond its control. These shall include, but not be limited to, acts of God, wars, strikes, fires, flood, storm, earthquake, shortages of labor or materials, labor disputes, transportation embargoes, acts of any government or agency thereof.

MODIFICATIONS OR RECONFIGURATION OF THE HARDWARE BY ANYONE OTHER THAN I-O OR I-O'S AUTHORIZED REPAIR FACILITY WILL VOID THIS HARDWARE WARRANTY.

Return-to-Depot Repair Policy

Terms, Conditions, and Limitations

Effective May 1, 1994^a.

For products covered by the I-O Corporation (I-O) Manufacturer's Limited Warranty (International), I-O's Return-to-Depot (RTD) Repair Policy provides customers with warranty service for a defective product, subject to the following terms and conditions:

Call Customer Support

If a product fails, call I-O Customer Support for assistance at:
(801) 972-1446 for all locations outside the United States.

Verify Product Failure

I-O will verify the product serial number, warranty coverage and product failure.

You are responsible for assisting in verifying the product failure

When I-O Customer Support verifies a product failure they will issue a Return Merchandise Authorization (RMA) number to authorize return of the failed product.

Select Your Preferred Repair Location

I-O's Customer Support Representative will assist you in identifying the nearest I-O authorized repair depot.

I-O's Customer Support Representative will provide you with an RMA transmittal form referencing the assigned RMA number and the authorized repair depot address.

Return Your Failed Unit

Return the failed product to the I-O authorized repair depot previously identified, enclosing the RMA transmittal form. When you return the failed product it must be shipped freight prepaid.

I-O's RTD Repair Policy applies only to warranted product failures. Buyer guarantees payment for non-warranted product repairs.

Buyer will pay reasonable labor and handling charges for each product returned for repair which is found to have no defect.

Install Your Repaired Unit

I-O's authorized repair depot will service the faulty unit and return it to you, freight prepaid.

You are responsible for installing the returned unit.

After receiving the repaired unit please call I-O Customer Support if any assistance is required.

^aI-O reserves the right to change the terms and conditions of this policy without notice.

FCC & European Compliance

This device complies with Part 15 of the FCC Rules. Operation is subject to the following two conditions: (1) this device may not cause harmful interference and (2) this device must accept any interference received including interference that may cause undesired operation.

This device is in conformity with the protection requirements of EC Council Directives 72/23/EEC, and 89/336/EEC on the approximation of the laws of the Member States relating to: Standard EN60950 (Safety of Information Technology Equipment); Standard EN50082-1 (Generic Immunity Standard for Residential, Commercial, and Light Industrial Products); and Standard EN55022 (Limits and Methods of Measurement of Radio Interference from Information Technology Equipment).